



ACHYRA[®]

Soluzioni Energetiche Sostenibili

Milano - Nola - HongKong - Guangzhou

PANNELLI FOTOVOLTAICI

ULICA SOLAR

HORAY SOLAR

Ulica Solar	4
UL-1762-108BDGNHH-30-EN-V2.0 425-450	5
UL-1762-108BDGNTH-30-EN-V2.0 430-455	7
UL-1952-120BDGNTH-30-EN-V2.0 480-505	9
UL-1762-108BHVNBH-30-EN-V2.0 430-455	11
UL-2278-144ADGNBB-30-EN-V2.0 570-595	13
UL-2278-144ADGNYB-30-EN-V3.0 570-595	15
UL-2382-132DDGNYB-30-EN-V3.0 600-625	17
UL-2384-132DGNBB-33-EN-V2.0 700-725	19
UL-2384-132DGNBYB-33-EN-V3.0 700-725	21
UL-2279-144HVBBC-35-EN-V1.2 545-555	23
UL-2384-132DGBBC-33-EN-V1.2 660-670	25
UL-2384-132HVBBC-35-EN-V1.2 660-670	27
QIN-UL-2382-144CDGNYB-30-EN-V2.0	29
UL-1762-108BDGNBB-30-EN-V2.0 430-455	31
UL-500M-108DDGN	33
Certificazioni Ulica Solar	35
Certificate_CE_en 202209	36
IEC 61215 61730	39
IT Fire Class094-26-Att	42
UL-1762-108BDGNBBC-30-EN-V1.2 445-455	44
UL-2278-144ADGNBBC-30-EN-V1.2	46
Ulica Solar~Fire Test Class 1 Certificate_1_	48
Horay Solar	53
HS186R-108TC-D-Alpine-455W	54
HS186R-120TC-D-Alpine-510W	56
HS186R-132TC-D-Alpine-560W	58
HS186R-144TC-D-Alpine-610W	60
HS191R-108TC-D-Basin-475W	62
HS191R-120TC-D-Basin-520W	64

HS191R-132TC-D-Basin-570W _____	66
HS191R-144TC-D-Basin-620W _____	68
HS210R-096TC-D-Cosmos-445~465W _____	70
HS210R-108TC-D-Cosmos-500~520W _____	72
HS210R-108TC-D-Cosmos-515W _____	74
HS210R-120TC-D-Cosmos-560~580W _____	76
HS210R-132TC-D-Cosmos-620~640W _____	78
HS210R-132TC-D-Cosmos-630W _____	80
HS199R-108TC-D-Delta-485W _____	82
HS199R-120TC-D-Delta-540W _____	84
HS199R-132TC-D-Delta-590W _____	86
HS199R-144TC-D-Delta-650W _____	88
HS210-132TC-D-Galaxy-700~730W-33Frame with C _____	90
HS210-132TC-D-Galaxy-700~730W-33Frame without C _____	92
HS210-132TC-D-Galaxy-720W-33Frame _____	94
HS182-108TC-D-Ocean-430~450W _____	96
HS182-120TC-D-Ocean-480~500W _____	98
HS182-132TC-D-Ocean-530~550W _____	100
HS182-144TC-D-Ocean-585~605W _____	102
HS182-144TC-D-Ocean-590W _____	104
HS_(570-590)TC_MHO-D_EN-30-Without-C-frame _____	106
HS186R-108TC-Alpine-455W _____	108
HS186R-120TC-Alpine-510W _____	110
HS186R-132TC-Alpine-560W _____	112
HS186R-144TC-Alpine-610W _____	114
HS191R-108TC-Basin-475W _____	116
HS191R-120TC-Basin-520W _____	118
HS191R-132TC-Basin-570W _____	120
HS191R-144TC-Basin-620W _____	122
HS182-108TC-Ocean-430~450W _____	124

HS182-120TC-Ocean-480~500W	126
HS182-132TC-Ocean-530~550W	128
HS182-144TC-Ocean-585~605W	130
Small-module-TUV-Rheinland	132
Solar-Creek-Series	133
Horay-Solar-Global-Installation-Manual	145
HS_(370-385)_MHL_EN	173
HS_(410-425)_MHL_EN	175
HS_(445-465)_MHL_EN	177
Certificazioni Horay Solar	179
ISO9001	180
ISO14001	181
ISO45001	182
CE	193
TUV-RHEINLAND-CERT-HORAY-SOLAR	197
TUV-RHEINLAND-CERT-(DOUBLE-GLASS)-HORAY-SOLAR	200
Manuali Horay Solar	203
InstallationManual_Horay-SG	204
Zavorre	226
Scheda tecnica Zavorra AZ-01	227
Scheda tecnica zavorre AZ-02	228

ULICA SOLAR



LEADING IN TECHNOLOGY

Established in August 2005, Ningbo Ulica Solar Co., Ltd. is an integrated PV manufacturer dedicated to the R&D, production, and sales of solar wafers, cells, and modules.

Black Jade series

Double Glass BiFacial N-Type TOPCon Solar Module

425~450Watt

Model: UL-***M-108BDGN

Maximum Efficiency: **22.52%**

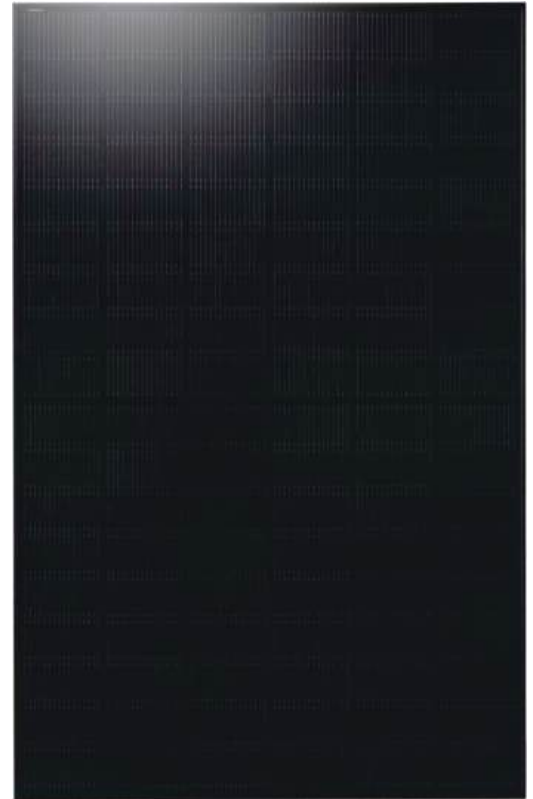

Cutting Free Technology

The half cells are made directly from half silicon wafer, reducing power losses and hidden cracks



Bifacial Mono Module

Capable of generating power at back side, 80±5% efficiency of the front side



Outstanding Mechanical load Resistance

2400 Pa wind load, 5400 Pa snow load



Anti-PID(potential induced degradation)

Passed anti-PID test under 85°C damp heat 85% relative humidity for 192 hours



Lower LCOE

Lower shading and resistive loss Lower temperature coefficient



Widely Applied To Various Scenarios

Flexibly applied to roofs, ground surfaces, water surfaces, mountainous areas, and other diverse environments

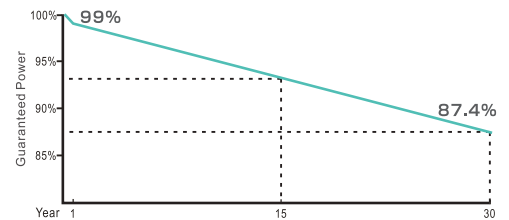

15 Year Product Warranty **1%** Power Degradation In The First Year

30 Year Linear Power Warranty **0.4%** Linear Power Degradation



CEC Listed



IEC 61215, IEC 61730

ISO 9001: 2015(Quality management systems)

ISO 14001: 2015 (Environmental management systems)

ISO45001: 2018 (Occupational health and safety)

UNI 9177 Ia CLASSE DI REAZIONE AL FUOCO:1



Add:No.238 Yunlin Middle Road,Ningbo China

TEL:+86-574-28828999

Email:sales@ulsolar.com.cn

ELECTRICAL SPECIFICATIONS

Module Type	UL-425M-108BDGN		UL-430M-108BDGN		UL-435M-108BDGN		UL-440M-108BDGN		UL-445M-108BDGN		UL-450M-108BDGN		
	STC*	NOCT*	STC*	NOCT*	STC*	NOCT*	STC*	NOCT*	STC*	NOCT*	STC*	NOCT*	
Maximum Power(Pmax)	W	425	322	430	326	435	330	440	333	445	337	450	341
Maximum Power Voltage(Vmp)	V	32.64	30.03	32.72	30.10	32.87	30.24	32.91	30.28	33.02	30.38	33.22	30.56
Maximum Power Current(Imp)	A	13.02	10.73	13.14	10.82	13.24	10.90	13.37	11.01	13.48	11.10	13.55	11.16
Open-circuit Current(Voc)	V	38.72	35.24	38.97	35.46	39.18	35.65	39.38	35.84	39.58	36.02	39.78	36.20
Short-circuit Current(Isc)	A	14.05	11.33	14.10	11.37	14.15	11.41	14.22	11.47	14.30	11.53	14.38	11.60
Module Efficiency STC	%	21.27		21.52		21.77		22.02		22.27		22.52	

*STC: Cell temperature: 25°C, Irradiance: 1000W/m², Air mass: 1.5G, Power measurement tolerance: ±3%
 *NOCT: Air temperature: 20°C, Irradiance: 1000W/m², Air mass: 1.5G, Wind speed: 1m/s

OPERATING PARAMETERS

Operating Temperature	-40°C~85°C
Maximum system voltage	DC1500V(IEC)
Maximum series fuse rating	30A
Nominal operating cell temperature	43±2°C
Power tolerance	0~+5Watt

TEMPERATURE RATINGS

Temperature coefficients of Pmax	-0.29%/°C
Temperature coefficients of Voc	-0.25%/°C
Temperature coefficients of Isc	0.046%/°C

I-V CURVE

I-V characteristics at different irradiances (reference to 450 W)

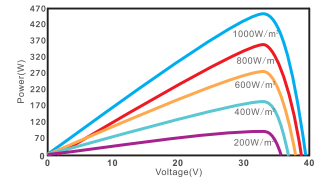
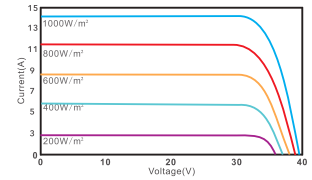

REAR SIDE POWER GAIN(REFERENCE TO 450W FRONT SIDE)

Pmax/W	450	473	495	518	540	563	585
Pmax gain	0%	5%	10%	15%	20%	25%	30%
Voc/V	39.78	39.78	39.78	39.78	39.78	39.78	39.78
Isc/A	14.38	15.10	15.82	16.54	17.26	17.98	18.69
Vmp/V	33.22	33.22	33.22	33.22	33.22	33.22	33.22
Imp/A	13.55	14.22	14.90	15.58	16.26	16.93	17.61

SPECIFICATIONS

Cell Type	N-type TOPCon Mono Half Cell	
No. of cells	108(6×9×2)	
Dimensions	1762*1134*30mm	
Weight	23.7kg	
Front Glass	2.0mm, Anti-Reflection Coating, High Transmission, Low Iron, Tempered Glass	
Back Glass	2.0mm, High Transmission, Low Iron, Tempered Glass	
Frame	Anodized Aluminium Alloy	
Junction Box	IP68, 3 diodes	
Connector	MC4 Compatible: PV-UL608 or others _____	Original: MC4-EVO2
Cable Length (Including Connector)	Short Cable: (+)400/(-)200mm or Customized Length _____	Long Cable: (+)1200/(-)1200mm

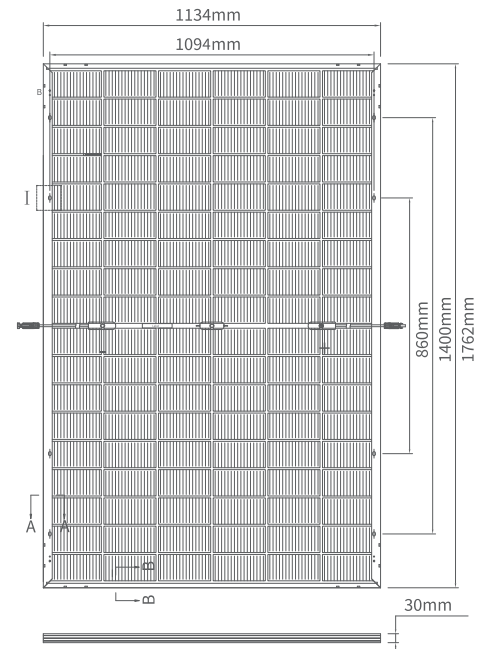

PACKAGING INFORMATION



36 Pcs/Pallet



72 Pcs/Stack



Length: 1775mm



Width: 1130mm



Height: 2540mm



Weight: 1770kg/Stack



13 Stack/40HQ
936 Pcs/40HQ



I



B-B



A-A

Length: ±2mm
Width: ±2mm
Height: ±1mm
Row Pitch: ±2mm



Specifications included in this datasheet are subject to change without notice.

Ulica Solar reserves the right of final interpretation.

Version number: UL-1762-108BDGNHH-30-EN-V2.0

Black Jade^{Flow} series

Double Glass BiFacial N-Type TOPCon Solar Module

430~455Watt

Model: UL-***M-108BDGN

Maximum Efficiency: **22.77%**

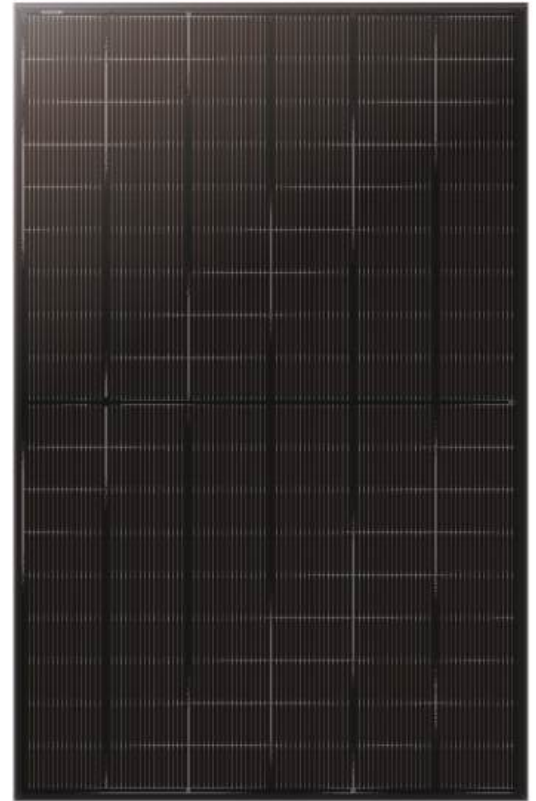

Cutting Free Technology

The half cells are made directly from half silicon wafer, reducing power losses and hidden cracks



Bifacial Mono Module

Capable of generating power at back side, 80±5% efficiency of the front side



Outstanding Mechanical load Resistance

2400 Pa wind load, 5400 Pa snow load



Anti-PID(potential induced degradation)

Passed anti-PID test under 85°C damp heat 85% relative humidity for 192 hours



Lower LCOE

Lower shading and resistive loss Lower temperature coefficient



Widely Applied To Various Scenarios

Flexibly applied to roofs, ground surfaces, water surfaces, mountainous areas, and other diverse environments

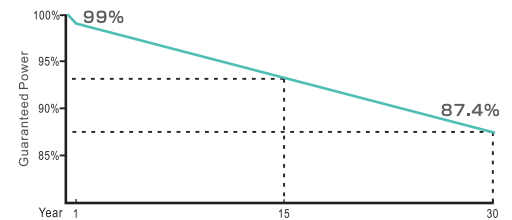

15 Year Product Warranty **1%** Power Degradation In The First Year

30 Year Linear Power Warranty **0.4%** Linear Power Degradation



CEC Listed



IEC 61215, IEC 61730

ISO 9001: 2015(Quality management systems)

ISO 14001: 2015 (Environmental management systems)

ISO45001: 2018 (Occupational health and safety)

UNI 9177 Ia CLASSE DI REAZIONE AL FUOCO:1



Add:No.238 Yunlin Middle Road,Ningbo China

TEL:+86-574-28828999

Email:sales@ulsolar.com.cn

ELECTRICAL SPECIFICATIONS

Module Type	UL-430M-108BDGN		UL-435M-108BDGN		UL-440M-108BDGN		UL-445M-108BDGN		UL-450M-108BDGN		UL-455M-108BDGN		
	STC*	NOCT*	STC*	NOCT*	STC*	NOCT*	STC*	NOCT*	STC*	NOCT*	STC*	NOCT*	
Maximum Power(Pmax)	W	430	326	435	330	440	333	445	337	450	341	455	345
Maximum Power Voltage(Vmp)	V	32.72	30.10	32.87	30.24	32.91	30.28	33.02	30.38	33.22	30.56	33.42	30.75
Maximum Power Current(Imp)	A	13.14	10.82	13.24	10.90	13.37	11.01	13.48	11.10	13.55	11.16	13.61	11.21
Open-circuit Current(Voc)	V	38.97	35.46	39.18	35.65	39.38	35.84	39.58	36.02	39.78	36.20	39.98	36.38
Short-circuit Current(Isc)	A	14.10	11.37	14.15	11.41	14.22	11.47	14.30	11.53	14.38	11.60	14.45	11.66
Module Efficiency STC	%	21.52		21.77		22.02		22.27		22.52		22.77	

*STC: Cell temperature: 25°C, Irradiance: 1000W/m², Air mass: 1.5G, Power measurement tolerance: ±3%
 *NOCT: Air temperature: 20°C, Irradiance: 1000W/m², Air mass: 1.5G, Wind speed: 1m/s

OPERATING PARAMETERS

Operating Temperature	-40°C~85°C
Maximum system voltage	DC1500V(IEC)
Maximum series fuse rating	30A
Nominal operating cell temperature	43±2°C
Power tolerance	0~+5Watt

TEMPERATURE RATINGS

Temperature coefficients of Pmax	-0.29%/°C
Temperature coefficients of Voc	-0.25%/°C
Temperature coefficients of Isc	0.046%/°C

I-V CURVE

I-V characteristics at different irradiances (reference to 450W)

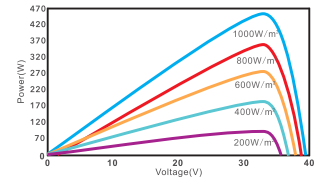
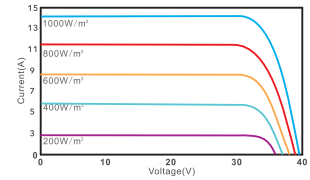

REAR SIDE POWER GAIN(REFERENCE TO 450W FRONT SIDE)

Pmax/W	450	473	495	518	540	563	585
Pmax gain	0%	5%	10%	15%	20%	25%	30%
Voc/V	39.78	39.78	39.78	39.78	39.78	39.78	39.78
Isc/A	14.38	15.10	15.82	16.54	17.26	17.98	18.69
Vmp/V	33.22	33.22	33.22	33.22	33.22	33.22	33.22
Imp/A	13.55	14.22	14.90	15.58	16.26	16.93	17.61

SPECIFICATIONS

Cell Type	N-type TOPCon Mono Half Cell	
No. of cells	108(6×9×2)	
Dimensions	1762*1134*30mm	
Weight	23.7kg	
Front Glass	2.0mm, Anti-Reflection Coating, High Transmission, Low Iron, Tempered Glass	
Back Glass	2.0mm, High Transmission, Low Iron, Tempered Glass	
Frame	Anodized Aluminium Alloy	
Junction Box	IP68, 3 diodes	
Connector	MC4 Compatible: PV-UL608 or Original: MC4-EVO2 or others _____	
Cable Length (Including Connector)	Short Cable: (+)400/(-)200mm or Long Cable: (+)1200/(-)1200mm or Customized Length _____	

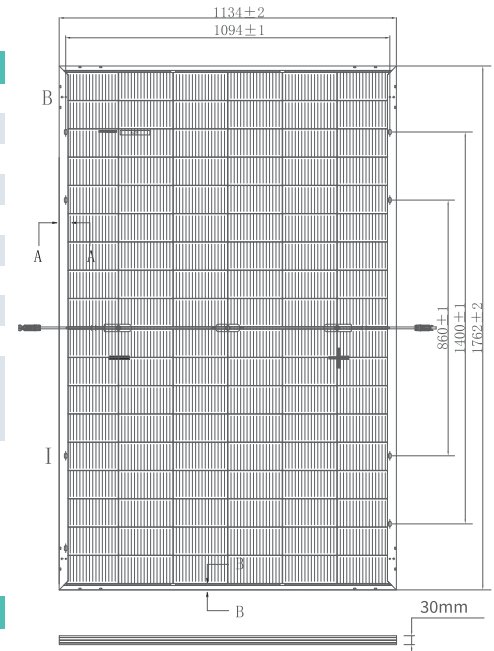

PACKAGING INFORMATION



36 Pcs/Pallet



72 Pcs/Stack



Length: 1775mm



Width: 1130mm



Height: 2540mm



Weight: 1770kg/Stack



13 Stack/40HQ
936 Pcs/40HQ



I



B-B



A-A

Length: ±2mm
Width: ±2mm
Height: ±1mm
Row Pitch: ±2mm



Specifications included in this datasheet are subject to change without notice.

Ulica Solar reserves the right of final interpretation.

Version number: UL-1762-108BDGNTH-30-EN-V2.0

Black Jade^{Flow} series

Double Glass BiFacial N-Type TOPCon Solar Module

480~505Watt

Model: UL-***M-120BDGN

Maximum Efficiency: **22.81%**



Cutting Free Technology

The half cells are made directly from half silicon wafer, reducing power losses and hidden cracks



Bifacial Mono Module

Capable of generating power at back side, 80±5% efficiency of the front side



Outstanding Mechanical load Resistance

2400 Pa wind load, 5400 Pa snow load



Anti-PID(potential induced degradation)

Passed anti-PID test under 85°C damp heat 85% relative humidity for 192 hours



Lower LCOE

Lower shading and resistive loss Lower temperature coefficient



Widely Applied To Various Scenarios

Flexibly applied to roofs, ground surfaces, water surfaces, mountainous areas, and other diverse environments

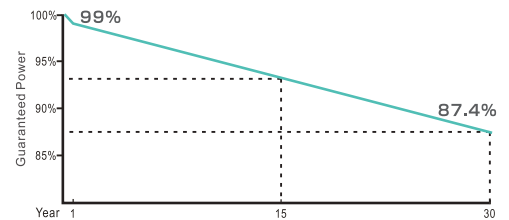

15 Year Product Warranty **1%** Power Degradation In The First Year

30 Year Linear Power Warranty **0.4%** Linear Power Degradation



CEC Listed



IEC 61215, IEC 61730

ISO 9001: 2015(Quality management systems)

ISO 14001: 2015 (Environmental management systems)

ISO45001: 2018 (Occupational health and safety)

UNI 9177 Ia CLASSE DI REAZIONE AL FUOCO:1



Add:No.238 Yunlin Middle Road,Ningbo China

TEL:+86-574-28828999

Email:sales@ulsolar.com.cn

ELECTRICAL SPECIFICATIONS

Module Type	UL-480M-120BDGN		UL-485M-120BDGN		UL-490M-120BDGN		UL-495M-120BDGN		UL-500M-120BDGN		UL-505M-120BDGN		
	STC*	NOCT*	STC*	NOCT*	STC*	NOCT*	STC*	NOCT*	STC*	NOCT*	STC*	NOCT*	
Maximum Power(Pmax)	W	480	364	485	368	490	371	495	375	500	379	505	383
Maximum Power Voltage(Vmp)	V	36.35	33.44	36.52	33.60	36.68	33.75	36.85	33.90	37.02	34.06	37.18	34.21
Maximum Power Current(Imp)	A	13.20	10.88	13.28	10.94	13.36	11.00	13.43	11.06	13.51	11.13	13.58	11.19
Open-circuit Current(Voc)	V	43.02	39.15	43.18	39.29	43.35	39.45	43.52	39.60	43.78	39.84	43.98	40.02
Short-circuit Current(Isc)	A	14.25	11.49	14.30	11.53	14.35	11.58	14.43	11.64	14.48	11.68	14.54	11.73
Module Efficiency STC	%	21.68		21.91		22.14		22.36		22.59		22.81	

*STC: Cell temperature: 25°C, Irradiance: 1000W/m², Air mass: 1.5G, Power measurement tolerance: ±3%
 *NOCT: Air temperature: 20°C, Irradiance: 1000W/m², Air mass: 1.5G, Wind speed: 1m/s

OPERATING PARAMETERS

Operating Temperature	-40°C~85°C
Maximum system voltage	DC1500V(IEC)
Maximum series fuse rating	30A
Nominal operating cell temperature	43±2°C
Power tolerance	0~+5Watt

TEMPERATURE RATINGS

Temperature coefficients of Pmax	-0.29%/°C
Temperature coefficients of Voc	-0.25%/°C
Temperature coefficients of Isc	0.046%/°C

I-V CURVE

I-V characteristics at different irradiances (reference to 500 W)

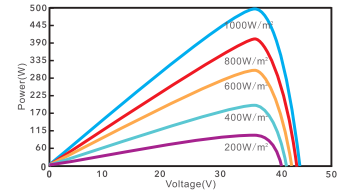
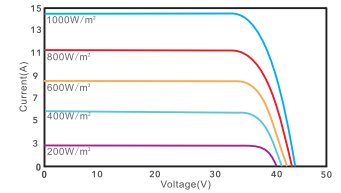

REAR SIDE POWER GAIN(REFERENCE TO 500W FRONT SIDE)

Pmax/W	500	525	550	575	600	625	650
Pmax gain	0%	5%	10%	15%	20%	25%	30%
Voc/V	43.78	43.78	43.78	43.78	43.78	43.78	43.78
Isc/A	14.48	15.20	15.93	16.65	17.38	18.10	18.82
Vmp/V	37.02	37.02	37.02	37.02	37.02	37.02	37.02
Imp/A	13.51	14.18	14.86	15.53	16.21	16.88	17.56

SPECIFICATIONS

Cell Type	N-type TOPCon Mono Half Cell	
No. of cells	120(6×10×2)	
Dimensions	1952*1134*30mm	
Weight	26.2kg	
Front Glass	2.0mm, Anti-Reflection Coating, High Transmission, Low Iron, Tempered Glass	
Back Glass	2.0mm, High Transmission, Low Iron, Tempered Glass	
Frame	Anodized Aluminium Alloy	
Junction Box	IP68, 3 diodes	
Connector	MC4 Compatible: PV-UL608 or others _____	Original: MC4-EVO2

Cable Length (Including Connector) Short Cable: (+)400/(-)200mm or Long Cable: (+)1200/(-)1200mm or Customized Length _____

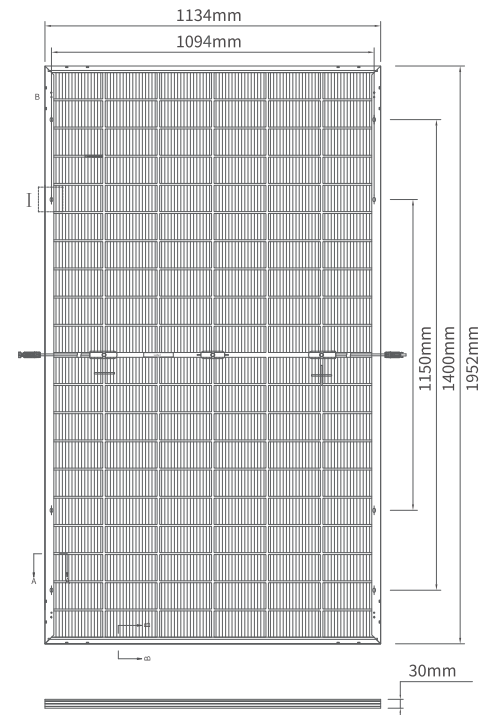

PACKAGING INFORMATION



36 Pcs/Pallet



72 Pcs/Stack



Length: 1965mm



Width: 1130mm



Height: 2540mm



Weight: 1954kg/Stack



12 Stack/40HQ
864Pcs/40HQ

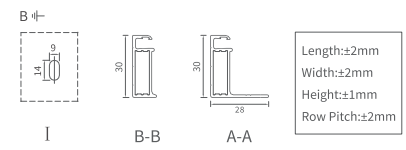

Specifications included in this datasheet are subject to change without notice.

Ulica Solar reserves the right of final interpretation.

Version number: UL-1952-120BDGNTH-30-EN-V2.0

Heron series

Singe Glass Mono-Facial N-Type TOPCon Solar Module

430~455Watt

Model: UL-***M-108BHVN

Maximum Efficiency: **22.77%**

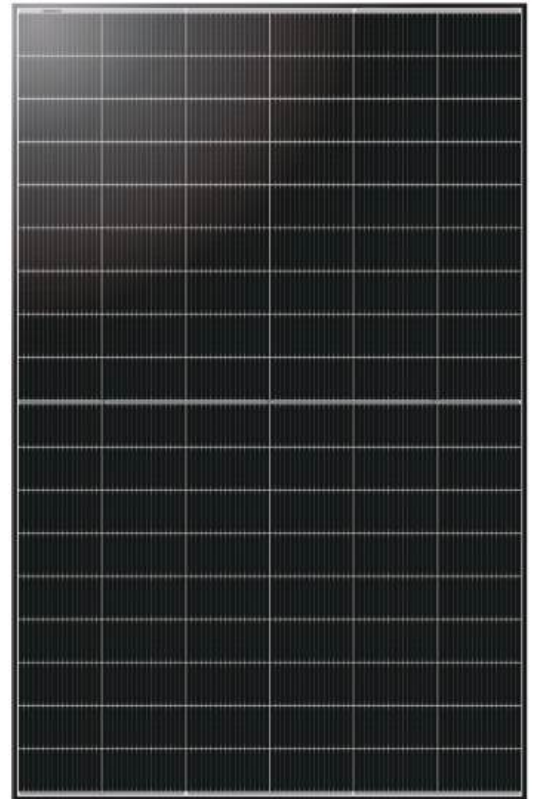

Cutting Free Technology

The half cells are made directly from half silicon wafer, reducing power losses and hidden cracks



Outstanding Mechanical load Resistance

2400 Pa wind load, 5400 Pa snow load



Longer Term Reliability

Successfully passed TUV IEC test



Lower LCOE

Lower shading and resistive loss Lower temperature coefficient



Anti-PID(potential induced degradation)

Passed anti-PID test under 85°C damp heat 85% relative humidity for 96 hours



Widely Applied To Various Scenarios

Flexibly applied to roofs, ground surfaces, water surfaces, mountainous areas, and other diverse environments

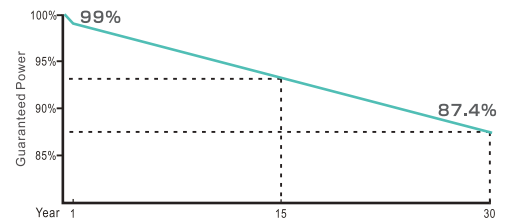

15 Year Product Warranty **1%** Power Degradation In The First Year

30 Year Linear Power Warranty **0.4%** Linear Power Degradation



CEC Listed



IEC 61215, IEC 61730

ISO 9001: 2015(Quality management systems)

ISO 14001: 2015 (Environmental management systems)

ISO45001: 2018 (Occupational health and safety)

UNI 9177 Ia CLASSE DI REAZIONE AL FUOCO:1



Add:No.238 Yunlin Middle Road,Ningbo China

TEL:+86-574-28828999

Email:sales@ulsolar.com.cn

ELECTRICAL SPECIFICATIONS

Module Type	UL-430M-108BHVN		UL-435M-108BHVN		UL-440M-108BHVN		UL-445M-108BHVN		UL-450M-108BHVN		UL-455M-108BHVN		
	STC*	NOCT*	STC*	NOCT*	STC*	NOCT*	STC*	NOCT*	STC*	NOCT*	STC*	NOCT*	
Maximum Power(Pmax)	W	430	326	435	330	440	333	445	337	450	341	455	345
Maximum Power Voltage(Vmp)	V	32.72	30.10	32.87	30.24	32.91	30.28	33.02	30.38	33.22	30.56	33.42	30.75
Maximum Power Current(Imp)	A	13.14	10.82	13.24	10.90	13.37	11.01	13.48	11.10	13.55	11.16	13.61	11.21
Open-circuit Current(Voc)	V	38.97	35.46	39.18	35.65	39.38	35.84	39.58	36.02	39.78	36.20	39.98	36.38
Short-circuit Current(Isc)	A	14.10	11.37	14.15	11.41	14.22	11.47	14.30	11.53	14.38	11.60	14.45	11.66
Module Efficiency STC	%	21.52		21.77		22.02		22.27		22.52		22.77	

*STC: Cell temperature: 25°C, Irradiance: 1000W/m², Air mass: 1.5G, Power measurement tolerance: ±3%
 *NOCT: Air temperature: 20°C, Irradiance: 1000W/m², Air mass: 1.5G, Wind speed: 1m/s

OPERATING PARAMETERS

Operating Temperature	-40°C~85°C
Maximum system voltage	DC1500V(IEC)
Maximum series fuse rating	25A
Nominal operating cell temperature	43±2°C
Power tolerance	0~+5Watt

TEMPERATURE RATINGS

Temperature coefficients of Pmax	-0.29%/°C
Temperature coefficients of Voc	-0.25%/°C
Temperature coefficients of Isc	0.046%/°C

SPECIFICATIONS

Cell Type	N-type TOPCon Mono Half Cell	
No. of cells	108(6×9×2)	
Dimensions	1762*1134*30mm	
Weight	21.0kg	
Front Glass	3.2mm, Anti-Reflection Coating, High Transmission, Low Iron, Tempered Glass	
Frame	Anodized Aluminium Alloy	
Junction Box	IP68, 3diodes	
Connector	MC4 Compatible: PV-UL608 or Original: MC4-EVO2 or others _____	
Cable Length (Including Connector)	4mm² Short Cable: (+)400/(-)200mm or Long Cable: (+)1200/(-)1200mm or Customized Length _____	

PACKAGING INFORMATION



36 Pcs/Pallet



72 Pcs/Stack



Length: 1775mm



Width: 1130mm



Height: 2540mm



Weight: 1576kg/Stack



13 Stack/40HQ
936 Pcs/40HQ

I-V CURVE

I-V characteristics at different irradiances (reference to 450 W)

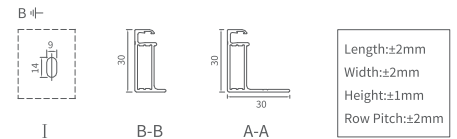
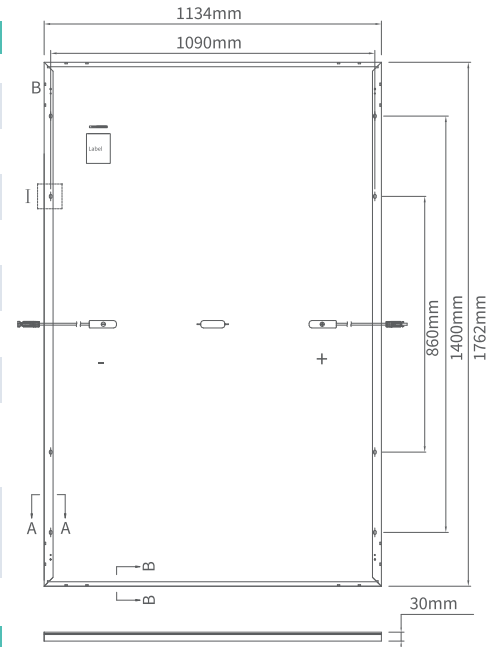
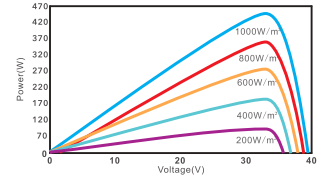
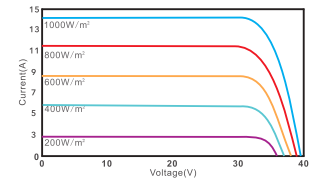

Specifications included in this datasheet are subject to change without notice.

Ulica Solar reserves the right of final interpretation.

Version number: UL-1762-108BHVNBH-30-EN-V2.0

Mate series

Double Glass BiFacial N-Type TOPCon Solar Module

570~595Watt

Model: UL-***M-144ADGN

Maximum Efficiency: **23.03%**

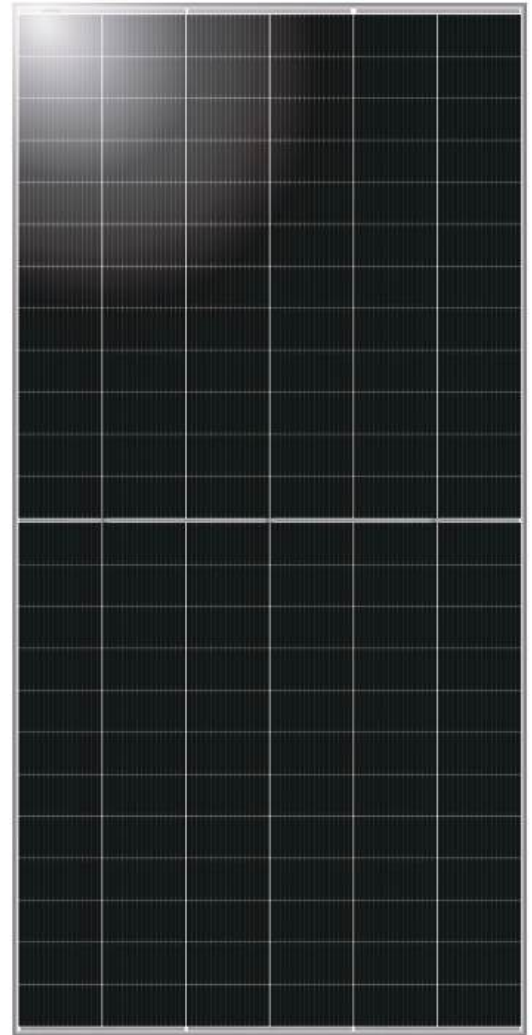

Bifacial Mono Module

Capable of generating power at back side, 80±5% efficiency of the front side



Longer Term Reliability

Passed the IEC63209-1:2021 standard test (With testing standards 2 to 3 times stricter than regular IEC requirements)



Outstanding Mechanical load Resistance

2400 Pa wind load, 5400 Pa snow load



Anti-PID(potential induced degradation)

Passed anti-PID test under 85°C damp heat 85% relative humidity for 192 hours



Lower LCOE

Lower shading and resistive loss Lower temperature coefficient



Widely Applied To Various Scenarios

Flexibly applied to roofs, ground surfaces, water surfaces, mountainous areas, and other diverse environments

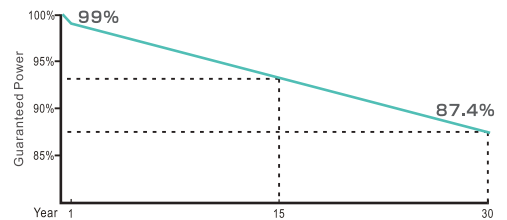

15 Year Product Warranty **1%** Power Degradation In The First Year

30 Year Linear Power Warranty **0.4%** Linear Power Degradation



CEC Listed



IEC 61215, IEC 61730

ISO 9001: 2015(Quality management systems)

ISO 14001: 2015 (Environmental management systems)

ISO45001: 2018 (Occupational health and safety)

UNI 9177 Ia CLASSE DI REAZIONE AL FUOCO:1



Add:No.238 Yunlin Middle Road,Ningbo China

TEL:+86-574-28828999

Email:sales@ulsolar.com.cn

ELECTRICAL SPECIFICATIONS

Module Type	UL-570M-144ADGN		UL-575M-144ADGN		UL-580M-144ADGN		UL-585M-144ADGN		UL-590M-144ADGN		UL-595M-144ADGN		
	STC*	NOCT*	STC*	NOCT*	STC*	NOCT*	STC*	NOCT*	STC*	NOCT*	STC*	NOCT*	
Maximum Power(Pmax)	W	570	432	575	436	580	440	585	443	590	447	595	451
Maximum Power Voltage(Vmp)	V	43.70	40.20	43.85	40.34	44.02	40.50	44.17	40.64	44.35	40.80	44.55	40.99
Maximum Power Current(Imp)	A	13.04	10.74	13.11	10.80	13.18	10.85	13.24	10.91	13.30	10.96	13.36	11.00
Open-circuit Current(Voc)	V	52.12	47.43	52.32	47.61	52.52	47.79	52.72	47.98	52.82	48.07	52.92	48.16
Short-circuit Current(Isc)	A	13.83	11.16	13.89	11.20	13.95	11.25	14.01	11.30	14.02	11.31	14.06	11.34
Module Efficiency STC	%	22.07		22.26		22.45		22.65		22.84		23.03	

*STC: Cell temperature: 25°C, Irradiance: 1000W/m², Air mass: 1.5G, Power measurement tolerance: ±3%
 *NOCT: Air temperature: 20°C, Irradiance: 1000W/m², Air mass: 1.5G, Wind speed: 1m/s

OPERATING PARAMETERS

Operating Temperature	-40°C~85°C
Maximum system voltage	DC1500V(IEC)
Maximum series fuse rating	30A
Nominal operating cell temperature	43±2°C
Power tolerance	0~+5Watt

TEMPERATURE RATINGS

Temperature coefficients of Pmax	-0.29%/°C
Temperature coefficients of Voc	-0.25%/°C
Temperature coefficients of Isc	0.046%/°C

I-V CURVE

I-V characteristics at different irradiances (reference to 580 W)

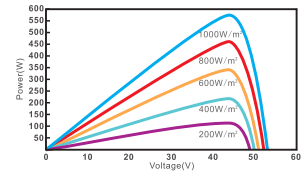
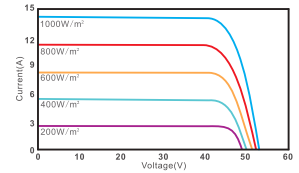

REAR SIDE POWER GAIN(REFERENCE TO 580W FRONT SIDE)

Pmax/W	580	609	638	667	696	725	754
Pmax gain	0%	5%	10%	15%	20%	25%	30%
Voc/V	52.52	52.52	52.53	52.52	52.52	52.52	52.52
Isc/A	13.95	14.65	15.35	16.04	16.74	17.44	18.14
Vmp/V	44.02	44.02	44.02	44.02	44.02	44.02	44.02
Imp/A	13.18	13.83	14.49	15.15	15.81	16.47	17.13

SPECIFICATIONS

Cell Type	N-type TOPCon Mono Half Cell	
No. of cells	144(6×12×2)	
Dimensions	2278*1134*30mm	
Weight	30.3kg	
Front Glass	2.0mm, Anti-Reflection Coating, High Transmission, Low Iron, Tempered Glass	
Back Glass	2.0mm, High Transmission, Low Iron, Tempered Glass	
Frame	Anodized Aluminium Alloy	
Junction Box	IP68, 3diodes	
Connector	MC4 Compatible: PV-UL608 or or others _____	Original: MC4-EVO2

Cable Length (Including Connector) Short Cable: (+)400/(-)200mm or Customized Length _____
 Long Cable: (+)1400/(-)1400mm

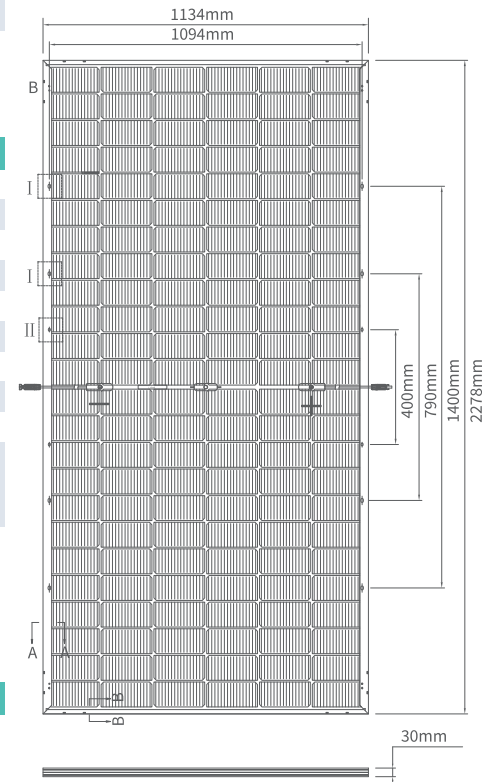

PACKAGING INFORMATION

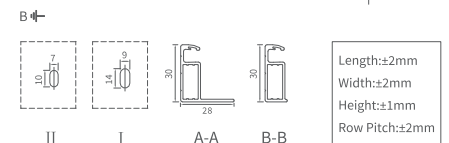
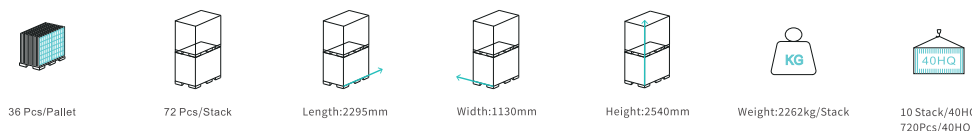

Specifications included in this datasheet are subject to change without notice.

Ulica Solar reserves the right of final interpretation.

Version number: UL-2278-144ADGNBB-30-EN-V2.0

Mate^{Veil} series

Double Glass BiFacial N-Type TOPCon Solar Module

570~595Watt

Model: UL-***M-144ADGN

Maximum Efficiency: **23.03%**



Bifacial Mono Module

Capable of generating power at back side, 80±5% efficiency of the front side



Longer Term Reliability

Passed the IEC63209-1:2021 standard test (With testing standards 2 to 3 times stricter than regular IEC requirements)



Outstanding Mechanical load Resistance

2400 Pa wind load, 5400 Pa snow load



Anti-PID(potential induced degradation)

Passed anti-PID test under 85°C damp heat 85% relative humidity for 192 hours



Lower LCOE

Lower shading and resistive loss Lower temperature coefficient



Widely Applied To Various Scenarios

Flexibly applied to roofs, ground surfaces, water surfaces, mountainous areas, and other diverse environments

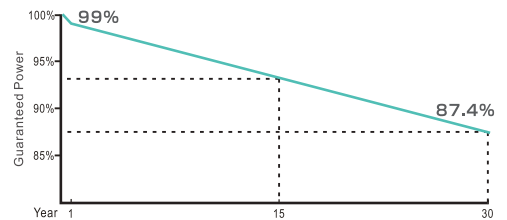
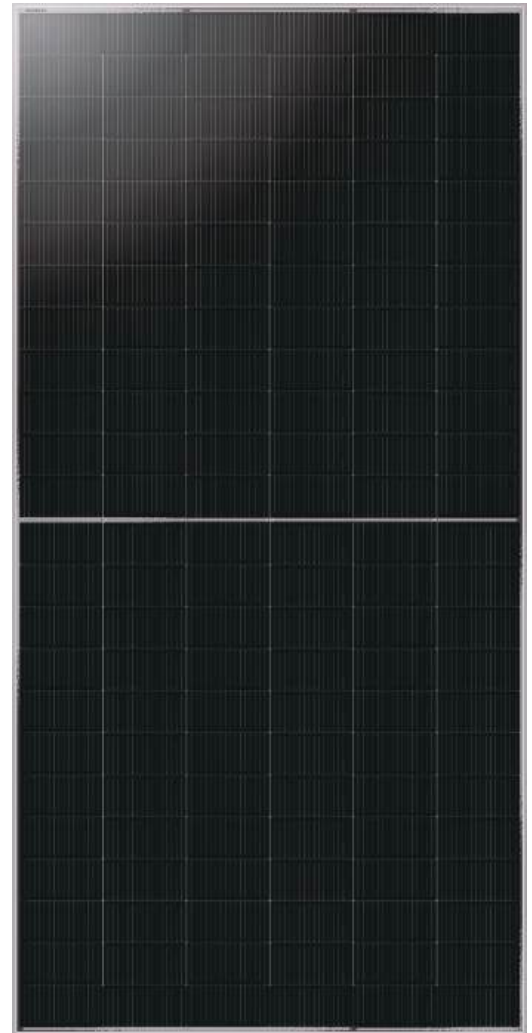

15 Year Product Warranty **1%** Power Degradation In The First Year

30 Year Linear Power Warranty **0.4%** Linear Power Degradation



CEC Listed



IEC 61215, IEC 61730

ISO 9001: 2015(Quality management systems)

ISO 14001: 2015 (Environmental management systems)

ISO45001: 2018 (Occupational health and safety)

UNI 9177 Ia CLASSE DI REAZIONE AL FUOCO:1



Add:No.238 Yunlin Middle Road,Ningbo China

TEL:+86-574-28828999

Email:sales@ulsolar.com.cn

ELECTRICAL SPECIFICATIONS

Module Type	UL-570M-144ADGN		UL-575M-144ADGN		UL-580M-144ADGN		UL-585M-144ADGN		UL-590M-144ADGN		UL-595M-144ADGN		
	STC*	NOCT*	STC*	NOCT*	STC*	NOCT*	STC*	NOCT*	STC*	NOCT*	STC*	NOCT*	
Maximum Power(Pmax)	W	570	432	575	436	580	440	585	443	590	447	595	451
Maximum Power Voltage(Vmp)	V	43.70	40.20	43.85	40.34	44.02	40.50	44.17	40.64	44.35	40.80	44.55	40.99
Maximum Power Current(Imp)	A	13.04	10.74	13.11	10.80	13.18	10.85	13.24	10.91	13.30	10.96	13.36	11.00
Open-circuit Current(Voc)	V	52.12	47.43	52.32	47.61	52.52	47.79	52.72	47.98	52.82	48.07	52.92	48.16
Short-circuit Current(Isc)	A	13.83	11.16	13.89	11.20	13.95	11.25	14.01	11.30	14.02	11.31	14.06	11.34
Module Efficiency STC	%	22.07		22.26		22.45		22.65		22.84		23.03	

*STC: Cell temperature: 25°C, Irradiance: 1000W/m², Air mass: 1.5G, Power measurement tolerance: ±3%
 *NOCT: Air temperature: 20°C, Irradiance: 1000W/m², Air mass: 1.5G, Wind speed: 1m/s

OPERATING PARAMETERS

Operating Temperature	-40°C~85°C
Maximum system voltage	DC1500V(IEC)
Maximum series fuse rating	30A
Nominal operating cell temperature	43±2°C
Power tolerance	0~+5Watt

TEMPERATURE RATINGS

Temperature coefficients of Pmax	-0.29%/°C
Temperature coefficients of Voc	-0.25%/°C
Temperature coefficients of Isc	0.046%/°C

I-V CURVE

I-V characteristics at different irradiances (reference to 580 W)

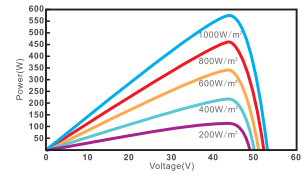
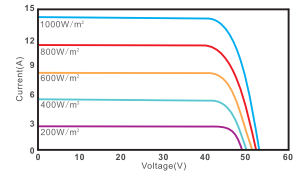

REAR SIDE POWER GAIN(REFERENCE TO 580W FRONT SIDE)

Pmax/W	580	609	638	667	696	725	754
Pmax gain	0%	5%	10%	15%	20%	25%	30%
Voc/V	52.52	52.52	52.53	52.52	52.52	52.52	52.52
Isc/A	13.95	14.65	15.35	16.04	16.74	17.44	18.14
Vmp/V	44.02	44.02	44.02	44.02	44.02	44.02	44.02
Imp/A	13.18	13.83	14.49	15.15	15.81	16.47	17.13

SPECIFICATIONS

Cell Type	N-type TOPCon Mono Half Cell	
No. of cells	144(6×12×2)	
Dimensions	2278*1134*30mm	
Weight	30.3kg	
Front Glass	2.0mm, Anti-Reflection Coating, High Transmission, Low Iron, Tempered Glass	
Back Glass	2.0mm, High Transmission, Low Iron, Tempered Glass	
Frame	Anodized Aluminium Alloy	
Junction Box	IP68, 3 diodes	
Connector	MC4 Compatible: PV-UL608 or others _____	Original: MC4-EVO2

Cable Length (Including Connector) Short Cable: (+)400/(-)200mm or Long Cable: (+)1400/(-)1400mm or Customized Length _____

PACKAGING INFORMATION



36 Pcs/Pallet



72 Pcs/Stack



Length: 2295mm



Width: 1130mm



Height: 2540mm



Weight: 2262kg/Stack



10 Stack/40HQ
720 Pcs/40HQ

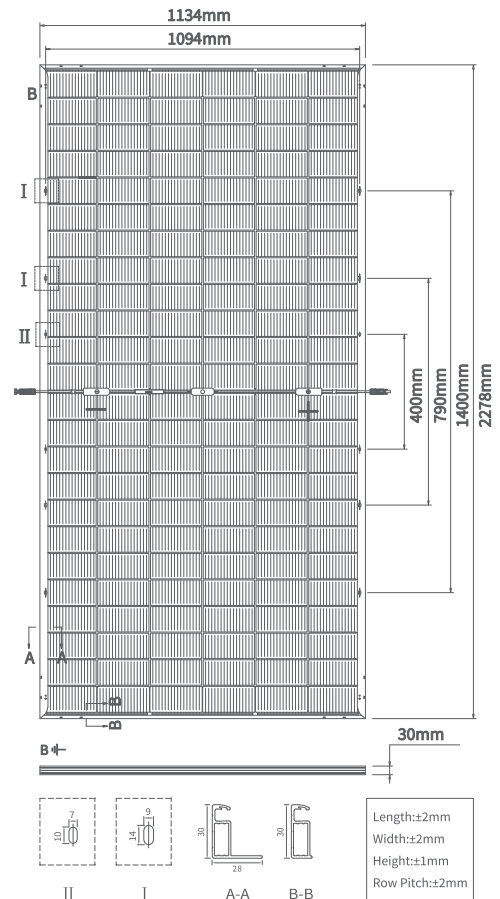

Specifications included in this datasheet are subject to change without notice.

Ulica Solar reserves the right of final interpretation.

Version number: UL-2278-144ADGNYB-30-EN-V3.0

Mate Pro^{Veil} series

Double Glass BiFacial N-Type TOPCon Solar Module

600~625Watt

Model: UL-***M-132DDGN

Maximum Efficiency: **23.14%**



Bifacial Mono Module

Capable of generating power at back side, 80±5% efficiency of the front side



Longer Term Reliability

Passed the IEC63209-1:2021 standard test (With testing standards 2 to 3 times stricter than regular IEC requirements)



Outstanding Mechanical load Resistance

2400 Pa wind load, 5400 Pa snow load



Anti-PID(potential induced degradation)

Passed anti-PID test under 85°C damp heat 85% relative humidity for 192 hours



Lower LCOE

Lower shading and resistive loss Lower temperature coefficient



Widely Applied To Various Scenarios

Flexibly applied to roofs, ground surfaces, water surfaces, mountainous areas, and other diverse environments

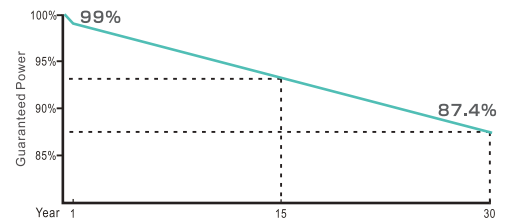
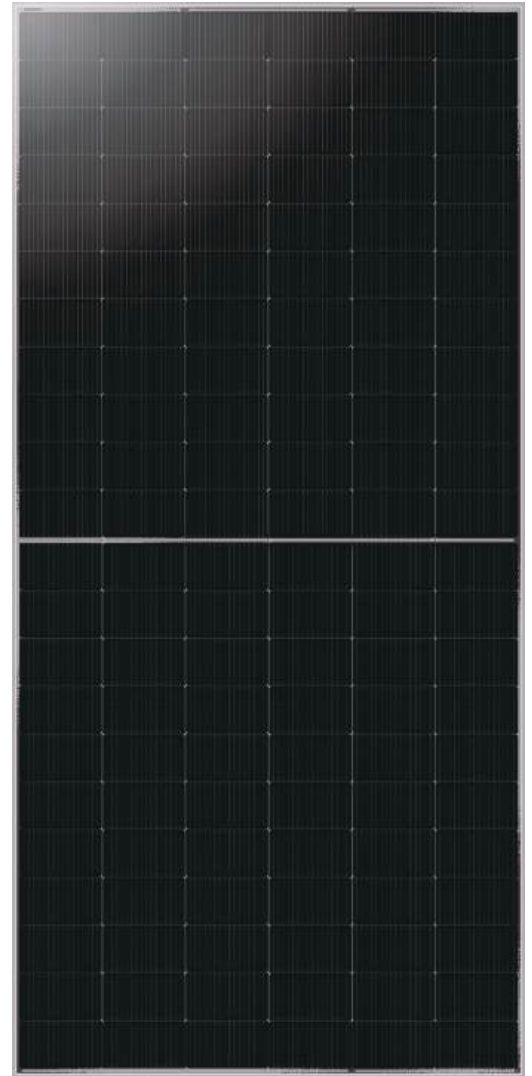

15 Year Product Warranty **1%** Power Degradation In The First Year

30 Year Linear Power Warranty **0.4%** Linear Power Degradation



CEC Listed



IEC 61215, IEC 61730

ISO 9001: 2015(Quality management systems)

ISO 14001: 2015 (Environmental management systems)

ISO45001: 2018 (Occupational health and safety)

UNI 9177 Ia CLASSE DI REAZIONE AL FUOCO:1



Add:No.238 Yunlin Middle Road,Ningbo China

TEL:+86-574-28828999

Email:sales@ulsolar.com.cn

ELECTRICAL SPECIFICATIONS

Module Type	UL-600M-132DDGN		UL-605M-132DDGN		UL-610M-132DDGN		UL-615M-132DDGN		UL-620M-132DDGN		UL-625M-132DDGN		
	STC*	NOCT*	STC*	NOCT*	STC*	NOCT*	STC*	NOCT*	STC*	NOCT*	STC*	NOCT*	
Maximum Power(Pmax)	W	600	455	605	458	610	462	615	466	620	470	625	474
Maximum Power Voltage(Vmp)	V	40.17	36.96	40.35	37.12	40.54	37.29	40.72	37.46	40.90	37.63	40.98	37.70
Maximum Power Current(Imp)	A	14.94	12.30	14.99	12.35	15.05	12.40	15.10	12.44	15.16	12.49	15.25	12.56
Open-circuit Current(Voc)	V	48.28	43.93	48.48	44.12	48.68	44.30	48.88	44.48	49.08	44.66	49.12	44.70
Short-circuit Current(Isc)	A	15.84	12.78	15.90	12.83	15.96	12.87	16.02	12.92	16.08	12.97	16.10	12.99
Module Efficiency STC	%	22.21		22.40		22.58		22.77		22.95		23.14	

*STC: Cell temperature: 25°C, Irradiance: 1000W/m², Air mass: 1.5G, Power measurement tolerance: ±3%
 *NOCT: Air temperature: 20°C, Irradiance: 1000W/m², Air mass: 1.5G, Wind speed: 1m/s

OPERATING PARAMETERS

Operating Temperature	-40°C~85°C
Maximum system voltage	DC1500V(IEC)
Maximum series fuse rating	30A
Nominal operating cell temperature	43±2°C
Power tolerance	0~+5Watt

TEMPERATURE RATINGS

Temperature coefficients of Pmax	-0.29%/°C
Temperature coefficients of Voc	-0.25%/°C
Temperature coefficients of Isc	0.046%/°C

I-V CURVE

I-V characteristics at different irradiances (reference to 615 W)

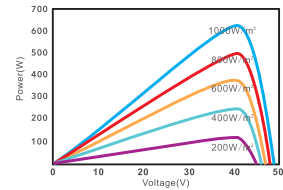
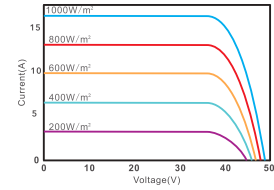

REAR SIDE POWER GAIN(REFERENCE TO 615W FRONT SIDE)

Pmax/W	615	646	677	707	738	769	800
Pmax gain	0%	5%	10%	15%	20%	25%	30%
Voc/V	48.88	48.88	48.88	48.88	48.88	48.88	48.88
Isc/A	16.02	16.82	17.62	18.42	19.22	20.03	20.83
Vmp/V	40.72	40.72	40.72	40.72	40.72	40.72	40.72
Imp/A	15.10	15.86	16.61	17.37	18.12	18.88	19.63

SPECIFICATIONS

Cell Type	N-type TOPCon Mono Half Cell	
No. of cells	132(6×11×2)	
Dimensions	2382*1134*30mm	
Weight	31.7kg	
Front Glass	2.0mm, Anti-Reflection Coating, High Transmission, Low Iron, Tempered Glass	
Back Glass	2.0mm, High Transmission, Low Iron, Tempered Glass	
Frame	Anodized Aluminium Alloy	
Junction Box	IP68, 3 diodes	
Connector	MC4 Compatible: PV-UL608 or others _____	Original: MC4-EVO2
Cable Length (Including Connector)	Short Cable: (+)400/(-)200mm or Customized Length _____	Long Cable: (+)1400/(-)1400mm

PACKAGING INFORMATION



36 Pcs/Pallet



72 Pcs/Stack



Length: 2390mm



Width: 1130mm



Height: 2540mm



Weight: 2365kg/Stack



10 Stack/40HQ
720Pcs/40HQ

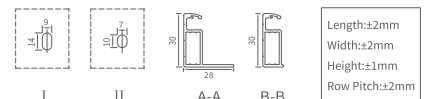
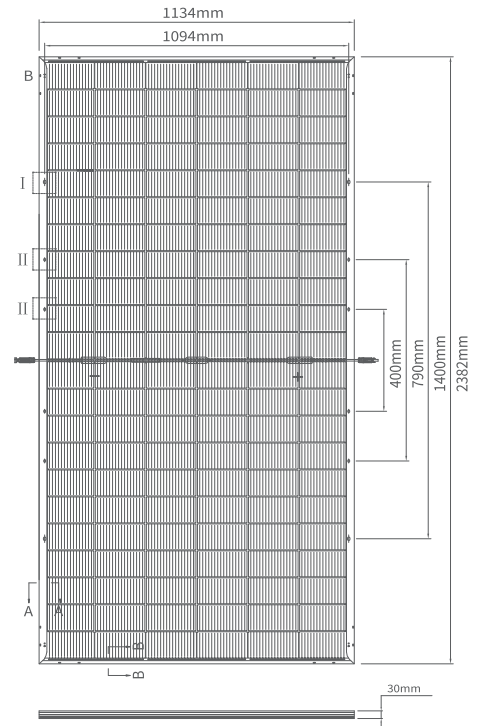

Specifications included in this datasheet are subject to change without notice.

Ulica Solar reserves the right of final interpretation.

Version number: UL-2382-132DDGNYB-30-EN-V3.0

Mountain series

Double Glass BiFacial N-Type TOPCon Solar Module

700~725Watt

Model: UL-***M-132DGN

Maximum Efficiency: **23.34%**



Cutting Free Technology

The half cells are made directly from half silicon wafer, reducing power losses and hidden cracks



Bifacial Mono Module

Capable of generating power at back side, 80±5% efficiency of the front side



Outstanding Mechanical load Resistance

2400 Pa wind load, 5400 Pa snow load



Anti-PID(potential induced degradation)

Passed anti-PID test under 85°C damp heat 85% relative humidity for 192 hours



Lower LCOE

Lower shading and resistive loss Lower temperature coefficient



Widely Applied To Various Scenarios

Flexibly applied to roofs, ground surfaces, water surfaces, mountainous areas, and other diverse environments

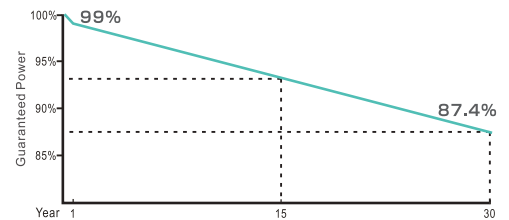
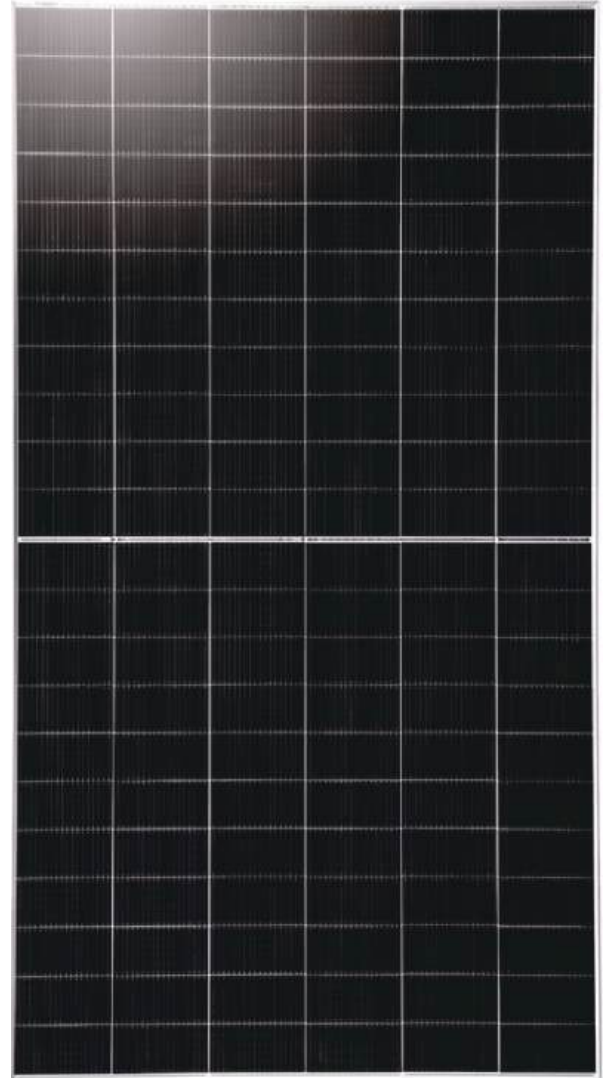

15 Year Product Warranty **1%** Power Degradation In The First Year

30 Year Linear Power Warranty **0.4%** Linear Power Degradation



CEC Listed



IEC 61215, IEC 61730

ISO 9001: 2015(Quality management systems)

ISO 14001: 2015 (Environmental management systems)

ISO45001: 2018 (Occupational health and safety)

UNI 9177 Ia CLASSE DI REAZIONE AL FUOCO:1



Add:No.238 Yunlin Middle Road,Ningbo China

TEL:+86-574-28828999

Email:sales@ulsolar.com.cn

ELECTRICAL SPECIFICATIONS

Module Type	UL-700M-132DGN		UL-705M-132DGN		UL-710M-132DGN		UL-715M-132DGN		UL-720M-132DGN		UL-725M-132DGN		
	STC*	NOCT*	STC*	NOCT*	STC*	NOCT*	STC*	NOCT*	STC*	NOCT*	STC*	NOCT*	
Maximum Power(Pmax)	W	700	530	705	534	710	538	715	542	720	546	725	549
Maximum Power Voltage(Vmp)	V	40.54	37.29	40.69	37.43	40.84	37.57	40.99	37.71	41.20	37.90	41.30	38.00
Maximum Power Current(Imp)	A	17.27	14.22	17.33	14.27	17.38	14.32	17.44	14.37	17.48	14.39	17.55	14.46
Open-circuit Current(Voc)	V	48.62	44.24	48.72	44.34	48.82	44.43	48.93	44.53	48.98	44.57	49.03	44.62
Short-circuit Current(Isc)	A	18.32	14.78	18.36	14.81	18.40	14.84	18.42	14.86	18.44	14.87	18.50	14.92
Module Efficiency STC	%	22.53		22.70		22.86		23.02		23.18		23.34	

*STC: Cell temperature: 25°C, Irradiance: 1000W/m², Air mass: 1.5G, Power measurement tolerance: ±3%
 *NOCT: Air temperature: 20°C, Irradiance: 1000W/m², Air mass: 1.5G, Wind speed: 1m/s

OPERATING PARAMETERS

Operating Temperature	-40°C~85°C
Maximum system voltage	DC1500V(IEC)
Maximum series fuse rating	35A
Nominal operating cell temperature	43±2°C
Power tolerance	0~+5Watt

TEMPERATURE RATINGS

Temperature coefficients of Pmax	-0.29%/°C
Temperature coefficients of Voc	-0.25%/°C
Temperature coefficients of Isc	0.046%/°C

I-V CURVE

I-V characteristics at different irradiances (reference to 720 W)

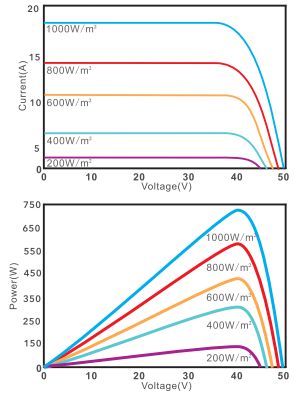

REAR SIDE POWER GAIN(REFERENCE TO 720W FRONT SIDE)

	720	756	792	828	864	900	936
Pmax/W							
Pmax gain	0%	5%	10%	15%	20%	25%	30%
Voc/V	48.98	48.98	48.98	48.98	48.98	48.98	48.98
Isc/A	18.44	19.36	20.28	21.21	22.13	23.05	23.97
Vmp/V	41.20	41.20	41.20	41.20	41.20	41.20	41.20
Imp/A	17.48	18.35	19.23	20.10	20.98	21.85	22.72

SPECIFICATIONS

Cell Type	N-type TOPCon Mono Half Cell	
No. of cells	132(6×11×2)	
Dimensions	2384*1303*33mm	
Weight	37.1kg	
Front Glass	2.0mm, Anti-Reflection Coating, High Transmission, Low Iron, Tempered Glass	
Back Glass	2.0mm, High Transmission, Low Iron, Tempered Glass	
Frame	Anodized Aluminium Alloy	
Junction Box	IP68, 3 diodes	
Connector	MC4 Compatible: PV-UL608 or others _____	Original: MC4-EVO2

Cable Length (Including Connector) Short Cable: (+)400/(-)200mm or Long Cable: (+)1400/(-)1400mm or Customized Length _____

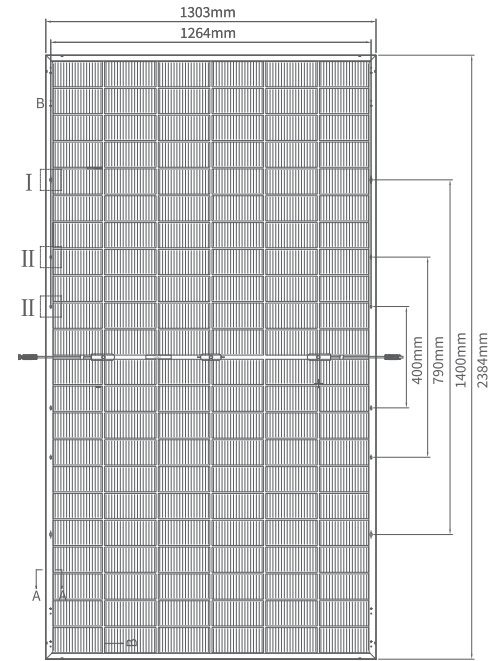

PACKAGING INFORMATION

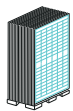

33 Pcs/Pallet

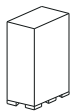

33 Pcs/Stack

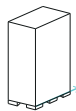

Length: 1320mm

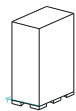

Width: 1130mm

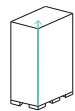

Height: 2416mm



Weight: 1260kg/Stack



18 Stack/40HQ
594Pcs/40HQ

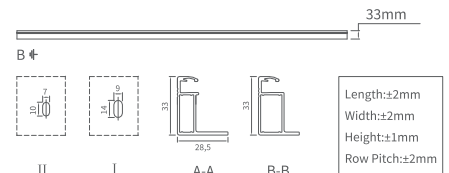

Length: ±2mm
Width: ±2mm
Height: ±1mm
Row Pitch: ±2mm



Specifications included in this datasheet are subject to change without notice.

Ulica Solar reserves the right of final interpretation.

Version number: UL-2384-132DGNBB-33-EN-V2.0

Mountain^{Veil} series

Double Glass BiFacial N-Type TOPCon Solar Module

700~725Watt

Model: UL-***M-132DGN

Maximum Efficiency: **23.34%**

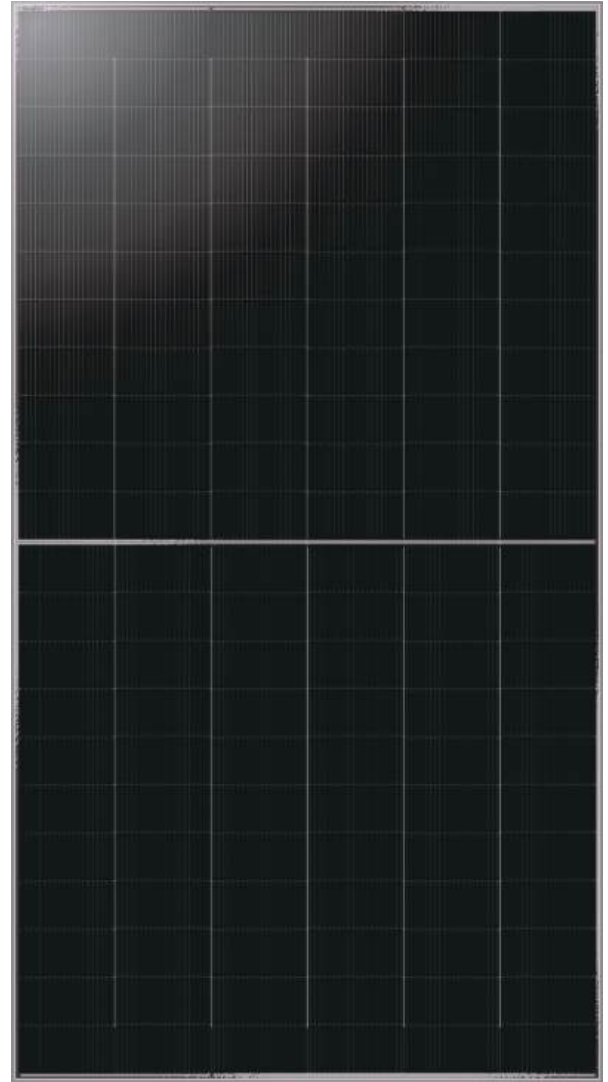

Cutting Free Technology

The half cells are made directly from half silicon wafer, reducing power losses and hidden cracks



Bifacial Mono Module

Capable of generating power at back side, 80±5% efficiency of the front side



Outstanding Mechanical load Resistance

2400 Pa wind load, 5400 Pa snow load



Anti-PID(potential induced degradation)

Passed anti-PID test under 85°C damp heat 85% relative humidity for 192 hours



Lower LCOE

Lower shading and resistive loss Lower temperature coefficient



Widely Applied To Various Scenarios

Flexibly applied to roofs, ground surfaces, water surfaces, mountainous areas, and other diverse environments

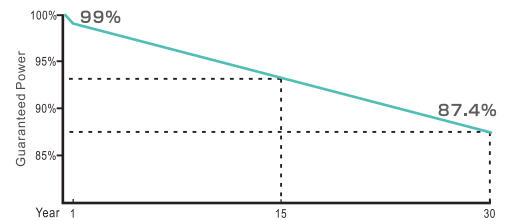

15 Year Product Warranty **1%** Power Degradation In The First Year

30 Year Linear Power Warranty **0.4%** Linear Power Degradation



CEC Listed



IEC 61215, IEC 61730

ISO 9001: 2015(Quality management systems)

ISO 14001: 2015 (Environmental management systems)

ISO45001: 2018 (Occupational health and safety)

UNI 9177 Ia CLASSE DI REAZIONE AL FUOCO:1



Add:No.238 Yunlin Middle Road,Ningbo China

TEL:+86-574-28828999

Email:sales@ulsolar.com.cn

ELECTRICAL SPECIFICATIONS

Module Type	UL-700M-132DGN		UL-705M-132DGN		UL-710M-132DGN		UL-715M-132DGN		UL-720M-132DGN		UL-725M-132DGN		
	STC*	NOCT*	STC*	NOCT*	STC*	NOCT*	STC*	NOCT*	STC*	NOCT*	STC*	NOCT*	
Maximum Power(Pmax)	W	700	530	705	534	710	538	715	542	720	546	725	549
Maximum Power Voltage(Vmp)	V	40.54	37.29	40.69	37.43	40.84	37.57	40.99	37.71	41.20	37.90	41.30	38.00
Maximum Power Current(Imp)	A	17.27	14.22	17.33	14.27	17.38	14.32	17.44	14.37	17.48	14.39	17.55	14.46
Open-circuit Current(Voc)	V	48.62	44.24	48.72	44.34	48.82	44.43	48.93	44.53	48.98	44.57	49.03	44.62
Short-circuit Current(Isc)	A	18.32	14.78	18.36	14.81	18.40	14.84	18.42	14.86	18.44	14.87	18.50	14.92
Module Efficiency STC	%	22.53		22.70		22.86		23.02		23.18		23.34	

*STC: Cell temperature: 25°C, Irradiance: 1000W/m², Air mass: 1.5G, Power measurement tolerance: ±3%
 *NOCT: Air temperature: 20°C, Irradiance: 1000W/m², Air mass: 1.5G, Wind speed: 1m/s

OPERATING PARAMETERS

Operating Temperature	-40°C~85°C
Maximum system voltage	DC1500V(IEC)
Maximum series fuse rating	35A
Nominal operating cell temperature	43±2°C
Power tolerance	0~+5Watt

TEMPERATURE RATINGS

Temperature coefficients of Pmax	-0.29%/°C
Temperature coefficients of Voc	-0.25%/°C
Temperature coefficients of Isc	0.046%/°C

I-V CURVE

I-V characteristics at different irradianations (reference to 720 W)

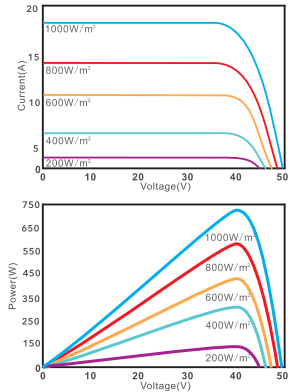

REAR SIDE POWER GAIN(REFERENCE TO 720W FRONT SIDE)

Pmax/W	720	756	792	828	864	900	936
Pmax gain	0%	5%	10%	15%	20%	25%	30%
Voc/V	48.98	48.98	48.98	48.98	48.98	48.98	48.98
Isc/A	18.44	19.36	20.28	21.21	22.13	23.05	23.97
Vmp/V	41.20	41.20	41.20	41.20	41.20	41.20	41.20
Imp/A	17.48	18.35	19.23	20.10	20.98	21.85	22.72

SPECIFICATIONS

Cell Type	N-type TOPCon Mono Half Cell	
No. of cells	132(6×11×2)	
Dimensions	2384*1303*33mm	
Weight	37.1kg	
Front Glass	2.0mm, Anti-Reflection Coating, High Transmission, Low Iron, Tempered Glass	
Back Glass	2.0mm, High Transmission, Low Iron, Tempered Glass	
Frame	Anodized Aluminium Alloy	
Junction Box	IP68, 3diodes	
Connector	MC4 Compatible: PV-UL608 or Original: MC4-EVO2 or others _____	
Cable Length (Including Connector)	Short Cable: (+)400/(-)200mm or Long Cable: (+)1400/(-)1400mm or Customized Length _____	

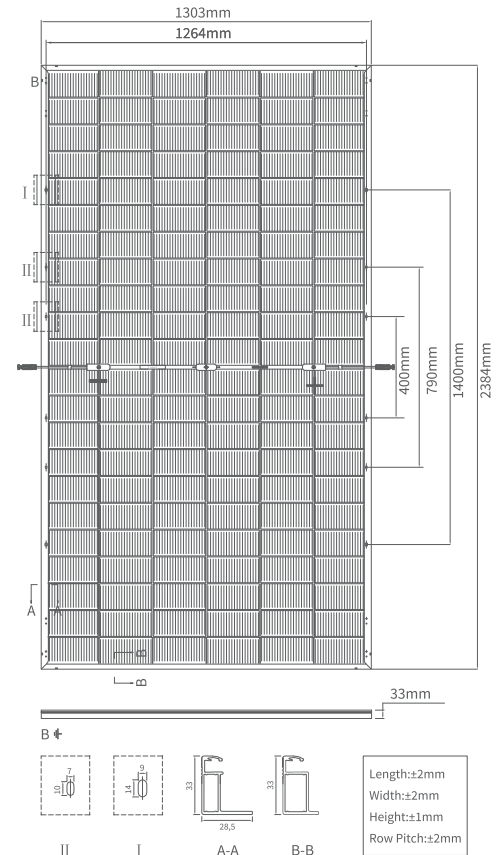

PACKAGING INFORMATION

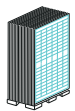

33 Pcs/Pallet

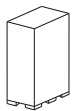

33 Pcs/Stack

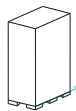

Length: 1320mm

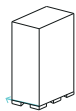

Width: 1130mm

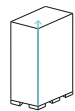

Height: 2416mm



Weight: 1260kg/Stack



18 Stack/40HQ
594Pcs/40HQ



Length: ±2mm
Width: ±2mm
Height: ±1mm
Row Pitch: ±2mm



Specifications included in this datasheet are subject to change without notice.

Ulica Solar reserves the right of final interpretation.

Version number: UL-2384-132DGNB-33-EN-V3.0

MONO HALF-CUT MODULE UL-545 | 550 | 555M-144HV

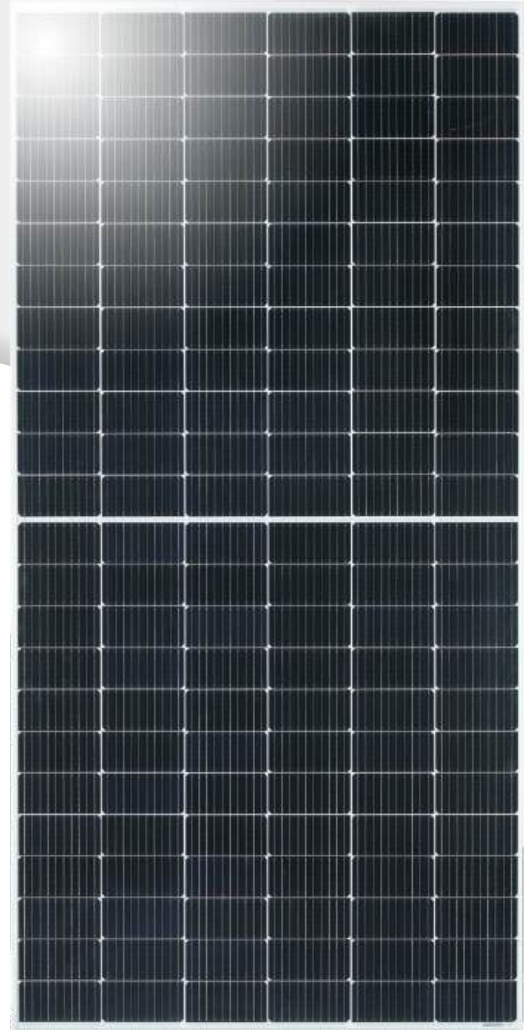
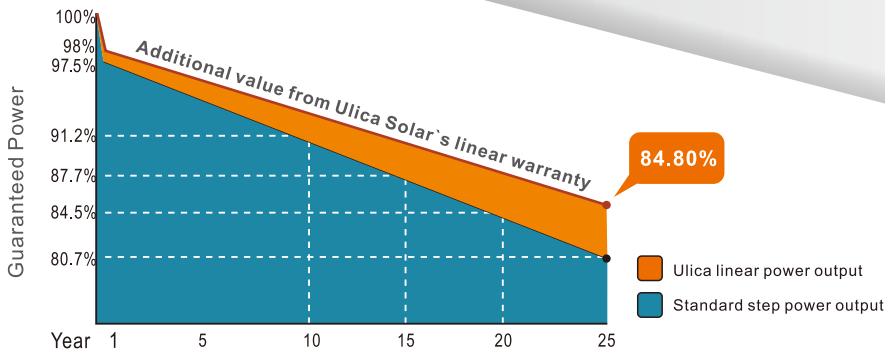

Anti-PID (potential induced degradation)
Passed anti-PID test under 85°C damp heat
85% relative humidity for 96 hours



Great Durability against extreme conditions
Passed salt mist corrosion test, ammonia corrosion test
dust & sand test, fire test, all certified by TÜV



Lower LCOE
Lower shading and resistive loss
Lower temperature coefficient



Outstanding mechanical load resistance
2400 Pa wind load, 5400 Pa snow load



CEC Listed



- IEC 61215, IEC 61730
- ISO 9001: 2015 (Quality management systems)
- ISO 14001: 2015 (Environmental management systems)
- ISO 45001: 2018 (Occupational health and safety)
- UNI 9177 la CLASSE DI REAZIONE AL FUOCO:1



Add: No. 238 Yunlin Middle Road, Wangchun Industrial District, Ningbo China

Tel: +86-574-28828939 Email: sales@ulsolar.com.cn

Fax: +86-574-28828997 Web: www.ulicasolar.com

ELECTRICAL PERFORMANCE

Electrical Parameters Standard Test Conditions

Module Type	UL-545M-144HV	UL-550M-144HV	UL-555M-144HV	
Power Output	P _{max} W	545	550	555
Power Tolerance	ΔP _{max} W	0/+5W		
Module Efficiency	η _m %	21.09	21.28	21.48
Voltage at P _{max}	V _m V	41.8	41.9	42.0
Current at P _{max}	I _m A	13.04	13.13	13.21
Open-Circuit Voltage	V _{oc} V	49.9	50.0	50.1
Short-Circuit Current	I _{sc} A	13.65	13.75	13.83

STC:1000w/m² irradiance,25C module temperature,AM1.5

THERMAL CHARACTERISTICS

Nominal Operating Cell Temperature	NOCT	°C	43±2
Temperature Coefficient of P _{max}	γ	%/°C	-0.340
Temperature Coefficient of V _{oc}	β	%/°C	-0.265
Temperature Coefficient of I _{sc}	α	%/°C	+0.049

OPERATING CONDITIONS

Max.System Voltage	DC1500V
Max.Series Fuse Rating	25A
Operating Temperature Range	-40°C~85°C
Max static snow load	5400Pa
Max static wind load	2400Pa
Application Class	A

CONSTRUCTION MATERIALS

Front Cover(material/type/thickness)	low-iron tempered glass/3.2mm
Cell(quantity/material/type/dimension)	144/monocrystalline/182X91mm
Encapsulant(material)	ethylene vinyl acetate(EVA)
Frame(material/anodization color)	anodized aluminum alloy/silver or black
Junction Box(protection degree)	IP68
	4mm ²
Cable(length/cross-sectionalarea)	Landscape:(+)1400/(-)1400mm or Customized Length
Plug Connector	MC4 compatible

GENERAL CHARACTERISTICS

Dimension(L/W/H)	2279/1134/35mm
Weight	27.5kg

PACKING CONFIGURATION

Pallet Size(L/W/H)	2320/1130/2540mm
Pallet Weight	1790kg
Pieces per Pallet	62pcs
Pieces per Container	620pcs

I-V CURVE

I-V characteristics at different irradiancies (reference to 555 W)

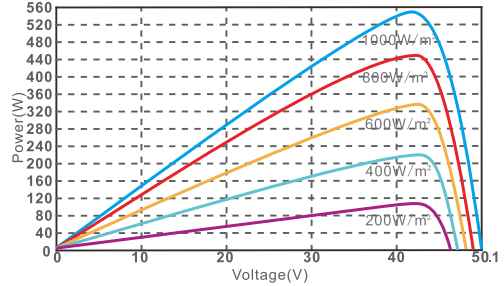
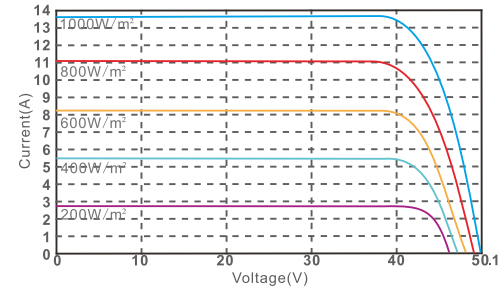

I-V characteristics at different temperature

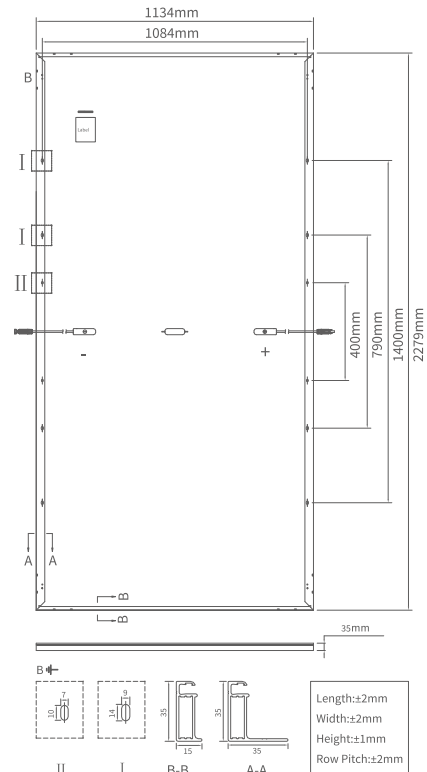
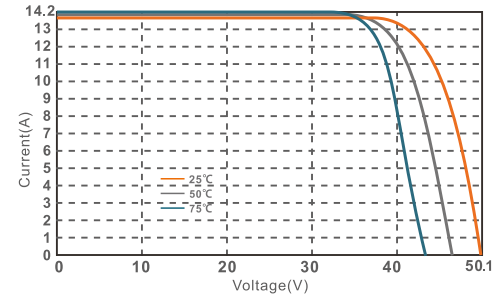

Specifications included in this datasheet are subject to change without notice.

Ulica Solar reserves the right of final interpretation.

Version No.: UL-2279-144HVBBC-35-EN-V1.2

DOUBLE-GLASS BIFACIAL MODULE UL-660 | 665 | 670 M-132DG

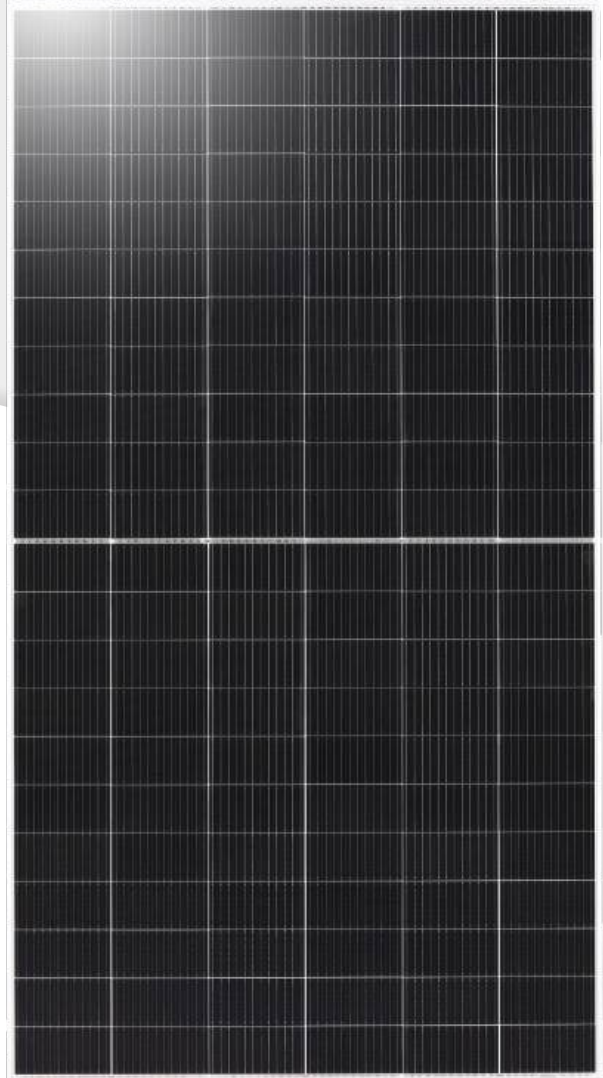
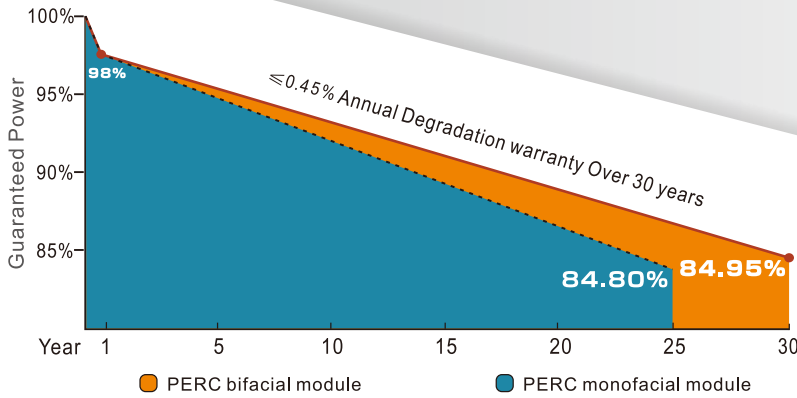

Bifacial Mono Module

Capable of generating power at back side, at least 70% efficiency of the front side



Anti-PID (potential induced degradation)

Passed anti-PID test under 85°C damp heat 85% relative humidity for 96 hours



Great Durability against extreme conditions

Passed salt mist corrosion test, ammonia corrosion test dust & sand test, fire test, all certified by TÜV



Lower LCOE

Lower shading and resistive loss
Lower temperature coefficient



Outstanding mechanical load resistance

2400 Pa wind load, 5400 Pa snow load



CEC Listed



- IEC 61215, IEC 61730
- ISO 9001: 2015 (Quality management systems)
- ISO 14001: 2015 (Environmental management systems)
- ISO 45001: 2018 (Occupational health and safety)
- UNI 9177 la CLASSE DI REAZIONE AL FUOCO:1



Add: No. 238 Yunlin Middle Road, Wangchun Industrial District, Ningbo China

Tel: +86-574-28828939

Email: sales@ulsolar.com.cn

Fax: +86-574-28828997

Web: www.ulicasolar.com

25/229

ELECTRICAL SPECIFICATIONS

Module Type	UL-660M-132DG		UL-665M-132DG		UL-670M-132DG		
	STC*	NOCT*	STC*	NOCT*	STC*	NOCT*	
Maximum Power (Pmax)	W	660	494	665	498	670	502
Maximum Power Voltage (Vmp)	V	38.22	35.16	38.30	35.24	38.41	35.34
Maximum Power Current (Imp)	A	17.27	14.06	17.36	14.13	17.44	14.20
Open-circuit Voltage (Voc)	V	46.01	41.87	46.12	41.97	46.21	42.05
Short-circuit Current (Isc)	A	18.44	14.88	18.53	14.95	18.62	15.03
Module Efficiency STC	%	21.25		21.41		21.57	
Operating Temperature	-40°C~85°C						
Maximum system voltage	DC1500V(IEC)						
Maximum series fuse rating	35A						
Power tolerance	0~+5Watt						
Temperature coefficients of Pmax	-0.34%/°C						
Temperature coefficients of Voc	-0.265%/°C						
Temperature coefficients of Isc	0.049%/°C						
Nominal operating cell temperature (NOCT)	43±2°C						

*STC : Cell temperature: 25°C, Irradiance: 1000 W/m², Air mass: 1.5G

*NOCT : Air temperature: 20°C, Irradiance: 800 W/m², Air mass: 1.5G, Wind speed: 1 m/s

SPECIFICATIONS

Cell Type	Mono-crystalline	
No. of cells	132(6×11×2)	
Dimensions	2384*1303*33mm	
Weight	37.4kg	
Glass	2.0mm+2.0mm, Anti-Reflection Coating, High Transmission, Low Iron, Tempered Glass	
Junction Box	IP68, 3 diodes	
Connector	MC4 Compatible	
Cable Length (including Connector)	4mm ² Landscape: (+)1400mm/(-)1400mm or Customized Length	
Packaging Configuration	33pcs/Pallet, 594pcs/40HQ Container	

Electrical characteristics with different rear side power gain (reference to 665 W front)

Pmax/W	Voc/V	Isc/A	Vmp/V	Imp/A	Pmax gain
665	46.12	18.53	38.30	17.36	0%
698	46.12	19.46	38.30	18.23	5%
732	46.12	20.38	38.30	19.10	10%
765	46.12	21.31	38.30	19.96	15%
798	46.12	22.24	38.30	20.83	20%
831	46.12	23.16	38.30	21.70	25%
865	46.12	24.09	38.30	22.57	30%

I-V CURVE

I-V characteristics at different irradiances (reference to 665 W)

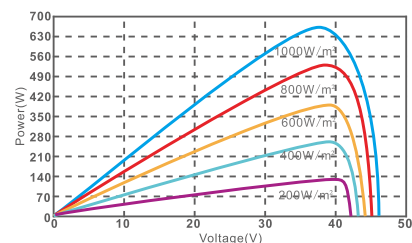
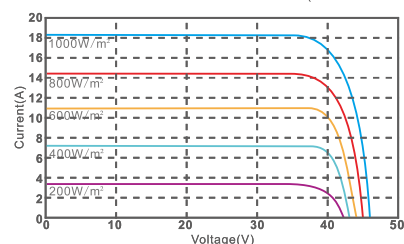

I-V characteristics at different temperature

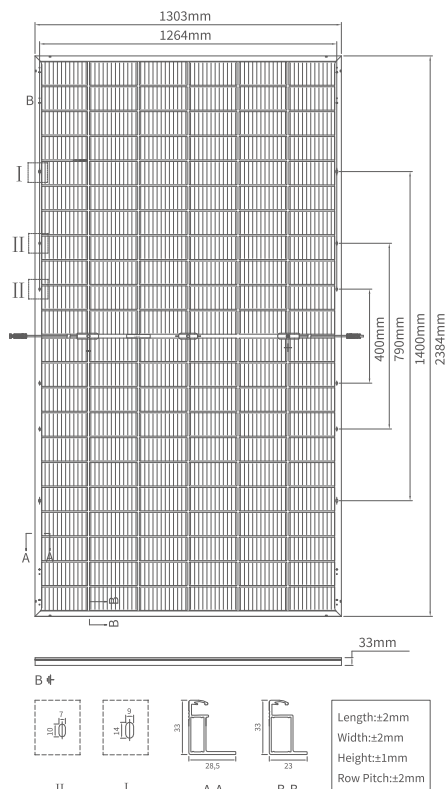
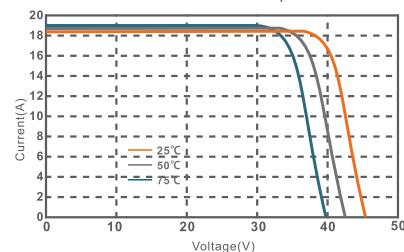

Specifications included in this datasheet are subject to change without notice.

Ulica Solar reserves the right of final interpretation.

Version No.: UL-2384-132DGBBC-33-EN-V1.2

MONO HALF-CUT MODULE

UL-660 | 665 | 670M-132HV

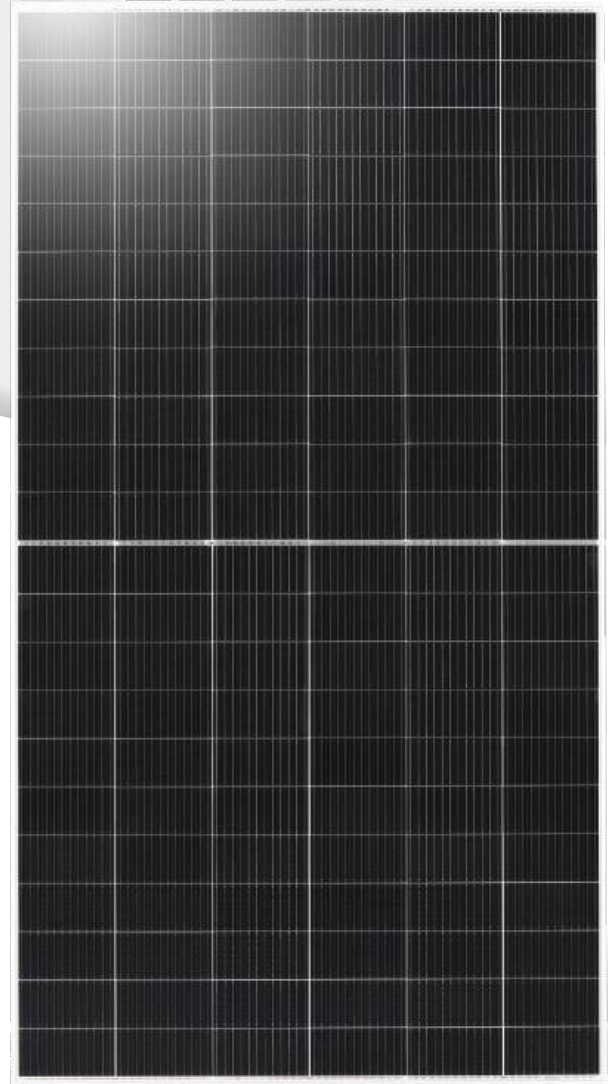
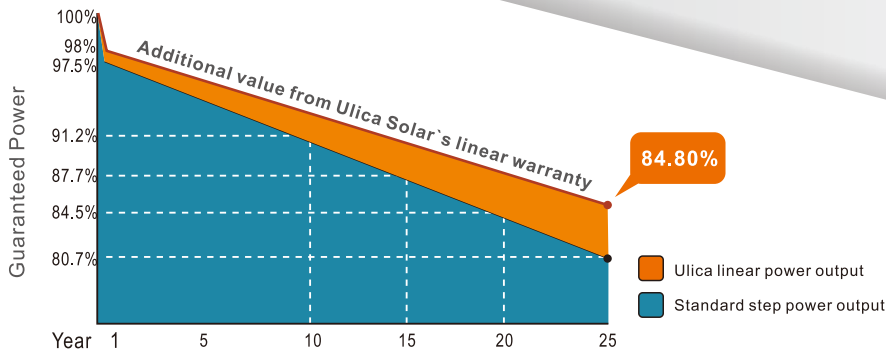

Anti-PID (potential induced degradation)
Passed anti-PID test under 85°C damp heat
85% relative humidity for 96 hours



Great Durability against extreme conditions
Passed salt mist corrosion test, ammonia corrosion test
dust & sand test, fire test, all certified by TÜV



Lower LCOE
Lower shading and resistive loss
Lower temperature coefficient



Outstanding mechanical load resistance
2400 Pa wind load, 5400 Pa snow load



CEC Listed



- IEC 61215, IEC 61730
- ISO 9001: 2015 (Quality management systems)
- ISO 14001: 2015 (Environmental management systems)
- ISO 45001: 2018 (Occupational health and safety)
- UNI 9177 la CLASSE DI REAZIONE AL FUOCO: 1



Add: No. 238 Yunlin Middle Road, Wangchun Industrial District, Ningbo China

Tel: +86-574-28828939 Email: sales@ulsolar.com.cn

Fax: +86-574-28828997 Web: www.ulicasolar.com

ELECTRICAL SPECIFICATIONS

Module Type	UL-660M-132HV		UL-665M-132HV		UL-670M-132HV	
	STC*	NOCT*	STC*	NOCT*	STC*	NOCT*
Maximum Power (Pmax) W	660	500	665	504	670	508
Maximum Power Voltage (Vmp) V	38.20	35.14	38.30	35.24	38.40	35.33
Maximum Power Current (Imp) A	17.28	14.23	17.36	14.30	17.45	14.37
Open-circuit Voltage (Voc) V	45.70	41.59	45.80	41.68	45.80	41.77
Short-circuit Current (Isc) A	18.44	14.87	18.53	14.95	18.62	15.02
Module Efficiency STC %	21.25		21.41		21.57	
Operating Temperature	-40°C~85°C					
Maximum system voltage	DC1500V(IEC)					
Maximum series fuse rating	30A					
Power tolerance	0~+5Watt					
Temperature coefficients of Pmax	-0.34%/°C					
Temperature coefficients of Voc	-0.265%/°C					
Temperature coefficients of Isc	0.049%/°C					
Nominal operating cell temperature (NOCT)	43±2°C					

*STC : Cell temperature: 25°C, Irradiance: 1000 W/m², Air mass: 1.5G

*NOCT : Air temperature: 20°C, Irradiance: 800 W/m², Air mass: 1.5G, Wind speed: 1 m/s

SPECIFICATIONS

Cell Type	Mono-crystalline
No. of cells	132(6×11×2)
Dimensions	2384*1303*35mm
Weight	33.6kg
Front Glass	3.2mm, Anti-Reflection Coating, High Transmission, Low Iron, Tempered Glass
Junction Box	IP68, 3 diodes
Connector	MC4 Compatible
Cable Length (Including Connector)	4mm² Landscape:(+)1400mm/(-)1400mm or Customized Length
Packaging Configuration	31pcs/Pallet, 558pcs/40HQ Container

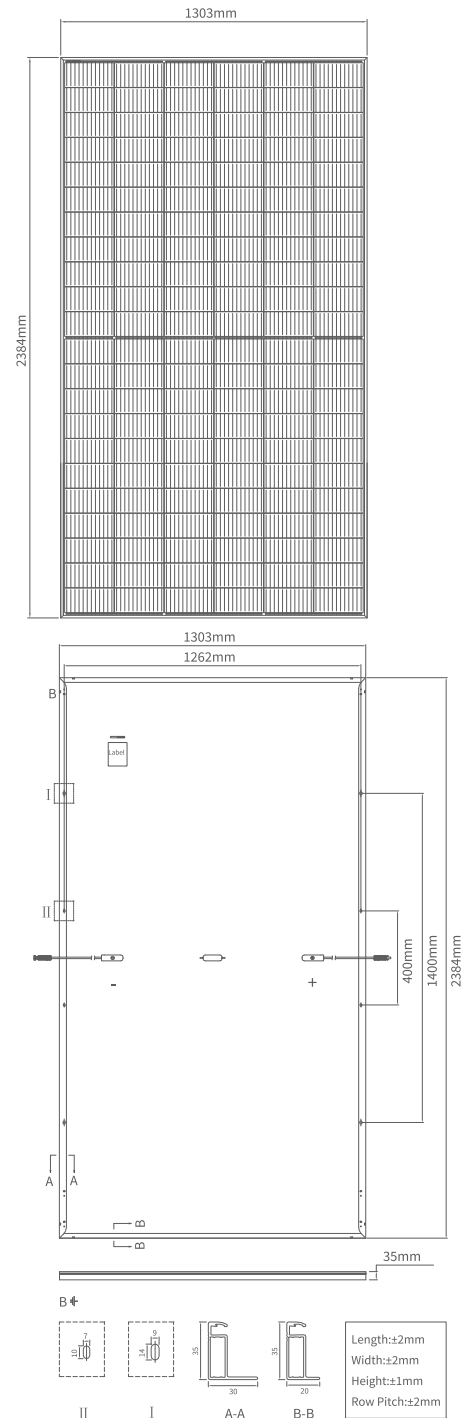

I-V CURVE

I-V characteristics at different irradiances (reference to 660 W)

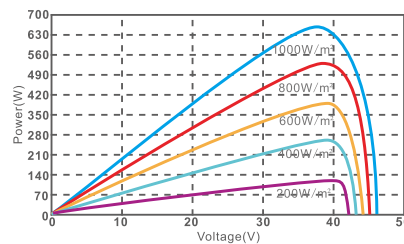
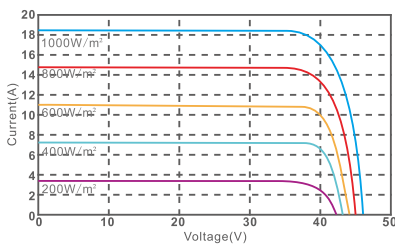

I-V characteristics at different temperature

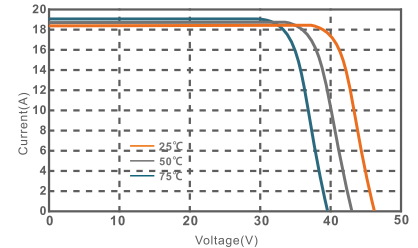

Specifications included in this datasheet are subject to change without notice.

Ulica Solar reserves the right of final interpretation.

Version No.: UL-2384-132HVBBC-35-EN-V1.2

Qin series (Preview Version)

Double Glass BiFacial N-Type TOPCon Solar Module

635~660Watt

Model: QIN-UL-***M-144CDGN

Maximum Efficiency: **24.43%**



Global Patent

Innovation Composite Finger Technology



Higher Output

Same dimension 40W higher, Module power up to 660W
Module efficiency up to 24.43%



Bifacial Mono Module

Capable of generating power at back side,
80±5% efficiency of the front side



Outstanding Mechanical load Resistance

2400 Pa wind load, 5400 Pa snow load



Anti-PID(potential induced degradation)

Passed anti-PID test under 85°C damp heat 85%
relative humidity for 192 hours



Lower LCOE

Lower shading and resistive loss Lower temperature coefficient



Widely Applied To Various Scenarios

Flexibly applied to roofs, ground surfaces, water surfaces, mountainous
areas, and other diverse environments

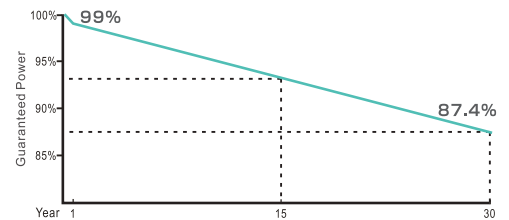

15 Year Product Warranty **1%** Power Degradation In The First Year

30 Year Linear Power Warranty **0.4%** Linear Power Degradation



CEC Listed



IEC 61215, IEC 61730

ISO 9001: 2015(Quality management systems)

ISO 14001: 2015 (Environmental management systems)

ISO45001: 2018 (Occupational health and safety)

UNI 9177 Ia CLASSE DI REAZIONE AL FUOCO:1



Add:No.238 Yunlin Middle Road,Ningbo China

TEL:+86-574-28828999

Email:sales@ulsolar.com.cn

ELECTRICAL SPECIFICATIONS

Module Type	UL-635M-144CDGN		UL-640M-144CDGN		UL-645M-144CDGN		UL-650M-144CDGN		UL-655M-144CDGN		UL-660M-144CDGN		
	STC*	NOCT*	STC*	NOCT*	STC*	NOCT*	STC*	NOCT*	STC*	NOCT*	STC*	NOCT*	
Maximum Power(Pmax)	W	635	481	640	485	645	489	650	493	655	496	660	500
Maximum Power Voltage(Vmp)	V	44.88	41.29	44.98	41.38	45.08	41.47	45.18	41.57	45.28	41.66	45.38	41.75
Maximum Power Current(Imp)	A	14.15	11.65	14.23	11.72	14.31	11.79	14.39	11.85	14.47	11.92	14.54	11.98
Open-circuit Current(Voc)	V	53.38	48.58	53.48	48.67	53.58	48.76	53.68	48.85	53.78	48.94	53.88	49.03
Short-circuit Current(Isc)	A	14.87	11.99	14.96	12.07	15.04	12.14	15.12	12.20	15.20	12.27	15.28	12.33
Module Efficiency STC	%	23.51		23.69		23.88		24.06		24.25		24.43	

*STC:Cell temperature:25°C,Irradiance:1000W/m²,Ari mass:1.5G,Power measurement tolerance: ±3%
*NOCT:Air temperature:20°C,Irradiance:1000W/m²,Ari mass:1.5G,Wind speed:1m/s

OPERATING PARAMETERS

Operating Temperature	-40°C~85°C
Maximum system voltage	DC1500V(IEC)
Maximum series fuse rating	30A
Nominal operating cell temperature	43±2°C
Power tolerance	0~+5Watt

TEMPERATURE RATINGS

Temperature coefficients of Pmax	-0.29%/°C
Temperature coefficients of Voc	-0.25%/°C
Temperature coefficients of Isc	0.046%/°C

I-V CURVE

I-V characteristics at different irradiances (reference to 655W)

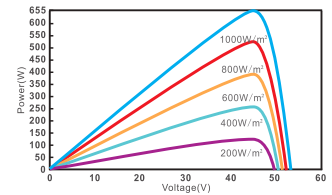
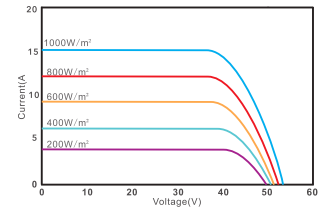

REAR SIDE POWER GAIN(REFERENCE TO 655W FRONT SIDE)

Pmax/W	655	688	721	753	786	819	852
Pmax gain	0%	5%	10%	15%	20%	25%	30%
Voc/V	53.78	53.78	53.78	53.78	53.78	53.78	53.78
Isc/A	15.20	15.96	16.72	17.48	18.24	19.00	19.76
Vmp/V	45.28	45.28	45.28	45.28	45.28	45.28	45.28
Imp/A	14.47	15.19	15.92	16.64	17.36	18.09	18.81

SPECIFICATIONS

Cell Type	N-type TOPCon Mono Half Cell	
No.of cells	144(6×12×2)	
Dimensions	2382*1134*30mm	
Weight	32.0kg	
Front Glass	2.0mm,Anti-Reflection Coating,High Transmission,Low Iron,Tempered Glass	
Back Glass	2.0mm,High Transmission,Low Iron,Tempered Glass	
Frame	Anodized Aluminium Alloy	
Junction Box	IP68,3diodes	
Connector	MC4 Compatible:PV-UL608 or others _____	Original:MC4-EVO2

Cable Length (Including Connector) Short Cable: (+)400/(-)200mm or Long Cable:(+)1400/(-)1400mm or Customized Length _____

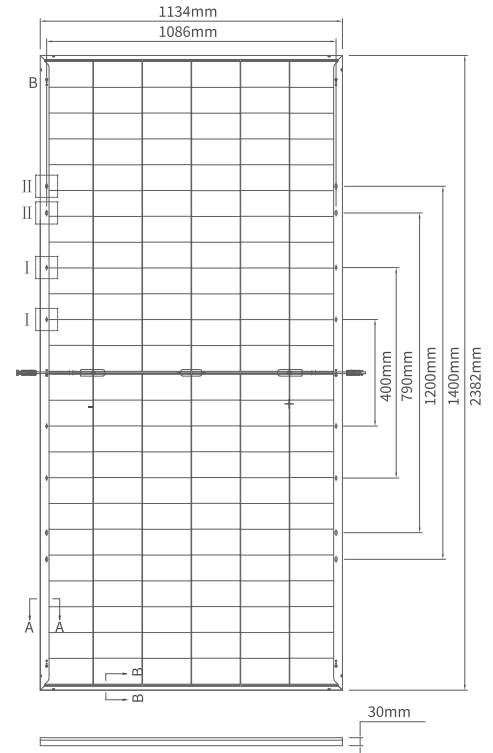

PACKAGING INFORMATION



36 Pcs/Pallet



72 Pcs/Stack



Length:2390mm



Width:1130mm



Height:2540mm



Weight:2387kg/Stack



10 Stack/40HQ
720Pcs/40HQ

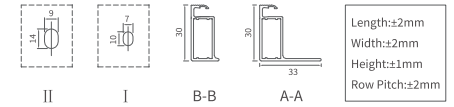

Specifications included in this datasheet are subject to change without notice.

Ulica Solar reserves the right of final interpretation.

Swan series

Double Glass BiFacial N-Type TOPCon Solar Module

430~455Watt

Model: UL-***M-108BDGN

Maximum Efficiency: **22.77%**



Cutting Free Technology

The half cells are made directly from half silicon wafer, reducing power losses and hidden cracks



Bifacial Mono Module

Capable of generating power at back side, 80±5% efficiency of the front side



Outstanding Mechanical load Resistance

2400 Pa wind load, 5400 Pa snow load



Anti-PID(potential induced degradation)

Passed anti-PID test under 85°C damp heat 85% relative humidity for 192 hours



Lower LCOE

Lower shading and resistive loss Lower temperature coefficient



Widely Applied To Various Scenarios

Flexibly applied to roofs, ground surfaces, water surfaces, mountainous areas, and other diverse environments

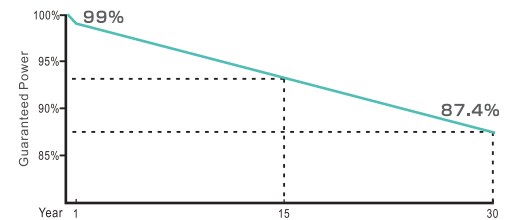

15 Year Product Warranty **1%** Power Degradation In The First Year

30 Year Linear Power Warranty **0.4%** Linear Power Degradation



CEC Listed



IEC 61215, IEC 61730

ISO 9001: 2015(Quality management systems)

ISO 14001: 2015 (Environmental management systems)

ISO45001: 2018 (Occupational health and safety)

UNI 9177 Ia CLASSE DI REAZIONE AL FUOCO:1



Add:No.238 Yunlin Middle Road,Ningbo China

TEL:+86-574-28828999

Email:sales@ulsolar.com.cn

ELECTRICAL SPECIFICATIONS

Module Type	UL-430M-108BDGN		UL-435M-108BDGN		UL-440M-108BDGN		UL-445M-108BDGN		UL-450M-108BDGN		UL-455M-108BDGN		
	STC*	NOCT*	STC*	NOCT*	STC*	NOCT*	STC*	NOCT*	STC*	NOCT*	STC*	NOCT*	
Maximum Power(Pmax)	W	430	326	435	330	440	333	445	337	450	341	455	345
Maximum Power Voltage(Vmp)	V	32.72	30.10	32.87	30.24	32.91	30.28	33.02	30.38	33.22	30.56	33.42	30.75
Maximum Power Current(Imp)	A	13.14	10.82	13.24	10.90	13.37	11.01	13.48	11.10	13.55	11.16	13.61	11.21
Open-circuit Current(Voc)	V	38.97	35.46	39.18	35.65	39.38	35.84	39.58	36.02	39.78	36.20	39.98	36.38
Short-circuit Current(Isc)	A	14.10	11.37	14.15	11.41	14.22	11.47	14.30	11.53	14.38	11.60	14.45	11.66
Module Efficiency STC	%	21.52		21.77		22.02		22.27		22.52		22.77	

*STC: Cell temperature: 25°C, Irradiance: 1000W/m², Air mass: 1.5G, Power measurement tolerance: ±3%
 *NOCT: Air temperature: 20°C, Irradiance: 1000W/m², Air mass: 1.5G, Wind speed: 1m/s

OPERATING PARAMETERS

Operating Temperature	-40°C~85°C
Maximum system voltage	DC1500V(IEC)
Maximum series fuse rating	30A
Nominal operating cell temperature	43±2°C
Power tolerance	0~+5Watt

TEMPERATURE RATINGS

Temperature coefficients of Pmax	-0.29%/°C
Temperature coefficients of Voc	-0.25%/°C
Temperature coefficients of Isc	0.046%/°C

I-V CURVE

I-V characteristics at different irradiances (reference to 450 W)

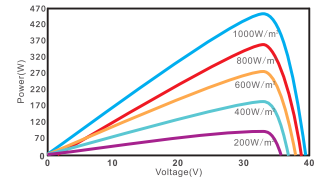
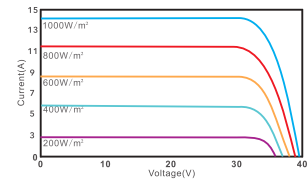

REAR SIDE POWER GAIN(REFERENCE TO 450W FRONT SIDE)

Pmax/W	450	473	495	518	540	563	585
Pmax gain	0%	5%	10%	15%	20%	25%	30%
Voc/V	39.78	39.78	39.78	39.78	39.78	39.78	39.78
Isc/A	14.38	15.10	15.82	16.54	17.26	17.98	18.69
Vmp/V	33.22	33.22	33.22	33.22	33.22	33.22	33.22
Imp/A	13.55	14.22	14.90	15.58	16.26	16.93	17.61

SPECIFICATIONS

Cell Type	N-type TOPCon Mono Half Cell	
No. of cells	108(6×9×2)	
Dimensions	1762*1134*30mm	
Weight	23.7kg	
Front Glass	2.0mm, Anti-Reflection Coating, High Transmission, Low Iron, Tempered Glass	
Back Glass	2.0mm, High Transmission, Low Iron, Tempered Glass	
Frame	Anodized Aluminium Alloy	
Junction Box	IP68, 3 diodes	
Connector	MC4 Compatible: PV-UL608 or Original: MC4-EVO2 or others _____	
Cable Length (Including Connector)	4mm ² Short Cable: (+)400/(-)200mm or Long Cable: (+)1200/(-)1200mm or Customized Length _____	

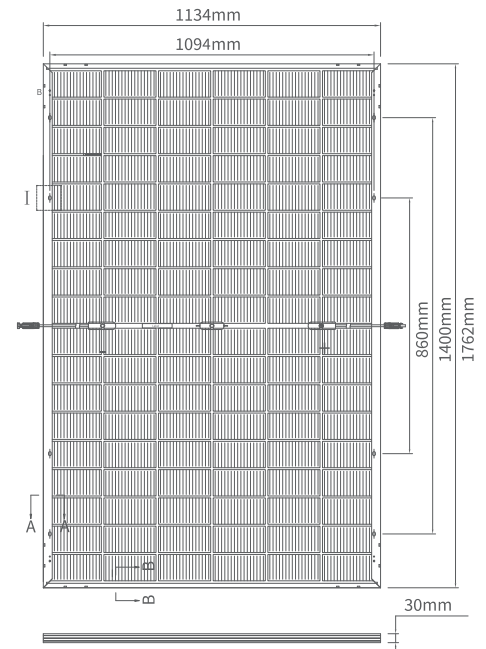

PACKAGING INFORMATION



36 Pcs/Pallet



72 Pcs/Stack



Length: 1775mm



Width: 1130mm



Height: 2540mm



Weight: 1770kg/Stack



13 Stack/40HQ
936 Pcs/40HQ



I



B-B



A-A

Length: ±2mm
Width: ±2mm
Height: ±1mm
Row Pitch: ±2mm



Specifications included in this datasheet are subject to change without notice.

Ulica Solar reserves the right of final interpretation.

Version number: UL-1762-108BDGNBB-30-EN-V2.0

Swan series

Double Glass BiFacial N-Type TOPCon Solar Module

495~520W

Model: UL-***M-108DDGN

Maximum Efficiency: **23.38%**



Bifacial Mono Module

Capable of generating power at back side, 80±5% efficiency of the front side



Longer Term Reliability

Passed the IEC63209-1:2021 standard test (With testing standards 2 to 3 times stricter than regular IEC requirements)



Outstanding Mechanical load Resistance

2mm+2mm front and back sides tempered glass, sturdy and durable, resistant to hail impact, with a snow load of 5400Pa and a wind load of 2400Pa



Anti-PID(potential induced degradation)

Passed anti-PID test under 85°C damp heat 85% relative humidity for 192 hours



Lower LCOE

Lower shading and resistive loss Lower temperature coefficient



Full-Scenario Resilience

Proven through rigorous resistance tests for salt mist, ammonia corrosion, sand & dust, and LeTID degradation

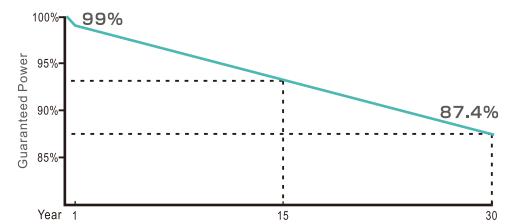
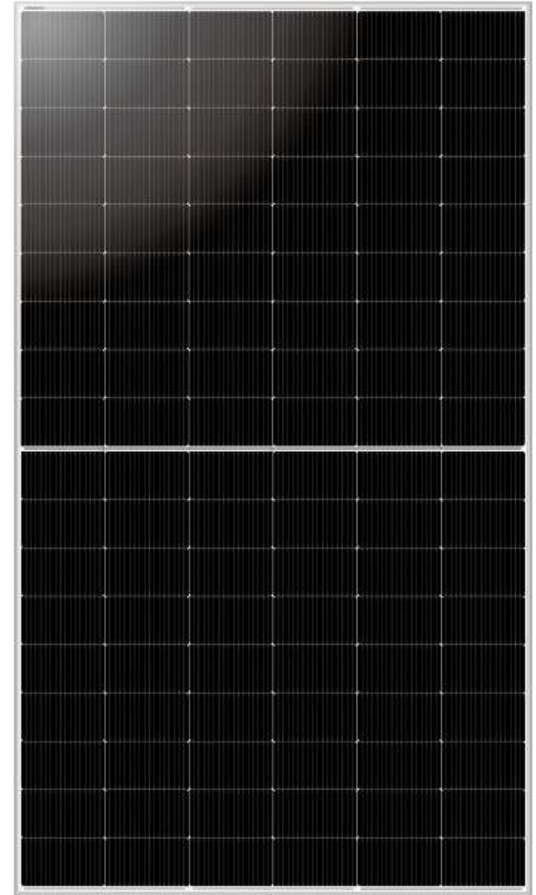

15 Year Product Warranty **1%** Power Degradation In The First Year

30 Year Linear Power Warranty **0.4%** Linear Power Degradation

IEC 61215, IEC 61730

ISO 9001: 2015(Quality management systems)

ISO 14001: 2015 (Environmental management systems)

ISO45001: 2018 (Occupational health and safety)

UNI 9177 Fire Test: Class 1



Add:No.238, Yunlin MiddleRoad,Gulin Town HaishuDistrict,Ningbo,China PC

TEL:+86-574-28828999

Email:sales@ulsolar.com.cn

ELECTRICAL SPECIFICATIONS

Module Type	UL-495M-108DDGN		UL-500M-108DDGN		UL-505M-108DDGN		UL-510M-108DDGN		UL-515M-108DDGN		UL-520M-108DDGN		
	STC*	NOCT*	STC*	NOCT*	STC*	NOCT*	STC*	NOCT*	STC*	NOCT*	STC*	NOCT*	
Maximum Power(Pmax)	W	495	375	500	379	505	383	510	386	515	390	520	394
Maximum Power Voltage(Vmp)	V	33.02	30.38	33.17	30.52	33.32	30.65	33.47	30.79	33.57	30.88	33.67	30.98
Maximum Power Current(Imp)	A	14.99	12.35	15.08	12.42	15.16	12.48	15.24	12.55	15.34	12.64	15.44	12.72
Open-circuit Current(Voc)	V	39.67	36.10	39.83	36.25	39.99	36.39	40.16	36.55	40.22	36.60	40.26	36.64
Short-circuit Current(Isc)	A	15.90	12.83	15.96	12.87	16.02	12.92	16.08	12.97	16.12	13.00	16.16	13.04
Module Efficiency STC	%	22.26		22.48		22.71		22.93		23.16		23.38	

*STC: Cell temperature: 25°C, Irradiance: 1000W/m², Air mass: 1.5G, Power measurement tolerance: ±3%
 *NOCT: Air temperature: 20°C, Irradiance: 1000W/m², Air mass: 1.5G, Wind speed: 1m/s

OPERATING PARAMETERS

Operating Temperature	-40°C~85°C
Maximum system voltage	DC1500V(IEC)
Maximum series fuse rating	30A
Nominal operating cell temperature	43±2°C
Power tolerance	0~+5Watt

TEMPERATURE RATINGS

Temperature coefficients of Pmax	-0.29%/°C
Temperature coefficients of Voc	-0.25%/°C
Temperature coefficients of Isc	0.046%/°C

I-V CURVE

I-V characteristics at different irradiances (reference to 520W)

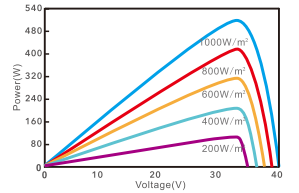
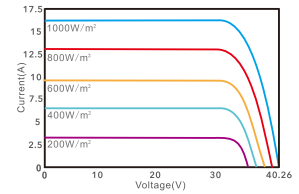

REAR SIDE POWER GAIN(REFERENCE TO 520W FRONT SIDE)

Pmax/W	520	546	572	598	624	650	676
Pmax gain	0%	5%	10%	15%	20%	25%	30%
Voc/V	40.26	40.26	40.26	40.26	40.26	40.26	40.26
Isc/A	16.16	16.97	17.78	18.58	19.39	20.20	21.01
Vmp/V	33.67	33.67	33.67	33.67	33.67	33.67	33.67
Imp/A	15.44	16.21	16.98	17.76	18.53	19.30	20.07

SPECIFICATIONS

Cell Type	N-type TOPCon Mono Half Cell	
No. of cells	108(6×9×2)	
Dimensions	1961*1134*30mm	
Weight	26.6kg	
Front Glass	2.0mm, Anti-Reflection Coating, High Transmission, Low Iron, Tempered Glass	
Back Glass	2.0mm, High Transmission, Low Iron, Tempered Glass	
Frame	Anodized Aluminium Alloy	
Junction Box	IP68, 3diodes	
Connector	MC4 Compatible: PV-UL608 or others _____	Original: MC4-EVO2A

Cable Length (Including Connector) Short Cable: (+)400/(-)200mm or Customized Length _____
 Long Cable: (+)1200/(-)1200mm

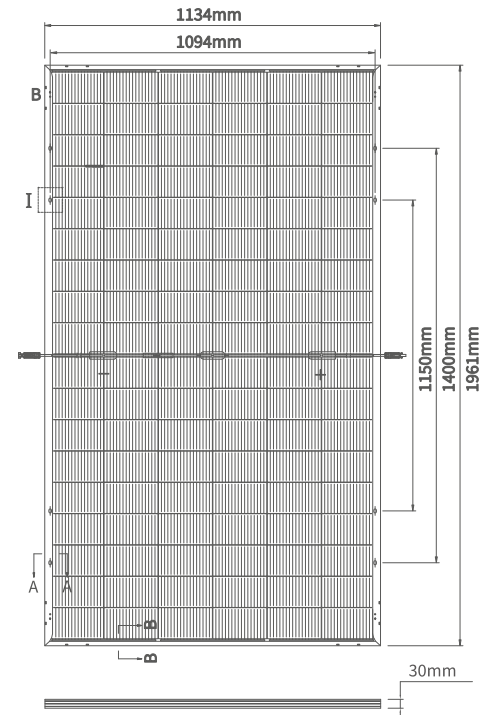

PACKAGING INFORMATION



37 Pcs/Pallet



74 Pcs/Stack



Length: 1975mm



Width: 1140mm



Height: 2550mm



Weight: 2037kg/Stack



12 Stack/40HQ
888Pcs/40HQ

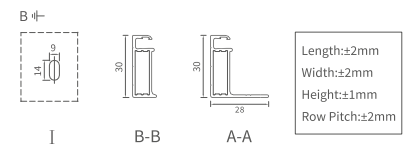

Specifications included in this datasheet are subject to change without notice.

Ulica Solar reserves the right of final interpretation.

Version number: UL-1961-108DDGNBB-30-EN-V1.1



ACHYRA[®]

Soluzioni Energetiche Sostenibili

Milano - Nola - HongKong - Guangzhou

CERTIFICAZIONI

ULICA SOLAR



Product Service

Attestation of Conformity

No. N8A 083334 0063 Rev. 08

Holder of Certificate: **Ningbo Ulica Solar Co., Ltd.**
NO.181-197, Shanshan Road
Wangchun Industrial District
315177 Ningbo
PEOPLE'S REPUBLIC OF CHINA

Product: **Crystalline Silicon Terrestrial Photovoltaic (PV) Modules**
Mono-Crystalline Silicon Photovoltaic Module

This Attestation of Conformity is issued on a voluntary basis according to the Low Voltage Directive 2014/35/EU relating to electrical equipment designed for use within certain voltage limits. It confirms that the listed equipment complies with the principal protection requirements of the directive and is based on the technical specifications applicable at the time of issuance. It refers only to the particular sample submitted for testing and certification. For details see: www.tuvsud.com/ps-cert

Test report no.: 704061806602-12

Date, 2022-09-05

(Zhulin Zhang)

Page 1 of 3

After preparation of the necessary technical documentation as well as the EU declaration of conformity the required CE marking can be affixed on the product. The declaration of conformity is issued under the sole responsibility of the manufacturer. Other relevant EU-directives have to be observed.



Attestation of Conformity

No. N8A 083334 0063 Rev. 08

Model(s):

1000 V DC system voltage Single Glass modules:

- UL-xxxM-72, xxx= 330 to 390 in step of 5
- UL-xxxM-60, xxx= 275 to 325 in step of 5
- UL-xxxM-54, xxx= 245 to 290 in step of 5
- UL-xxxM-48, xxx= 220 to 260 in step of 5
- UL-xxxM-24, xxx= 110 to 130 in step of 5

1500 V DC system voltage Single Glass modules:

- UL-xxxM-72HV, xxx= 330 to 390 in step of 5
- UL-xxxM-60HV, xxx= 275 to 325 in step of 5
- UL-xxxM-54HV, xxx= 245 to 290 in step of 5
- UL-xxxM-48HV, xxx= 220 to 260 in step of 5
- UL-xxxM-24HV, xxx= 110 to 130 in step of 5

Half cell 1000 V DC system voltage Single Glass modules:

- UL-xxxM-144, xxx= 370 to 415 in step of 5
- UL-xxxM-120, xxx= 305 to 345 in step of 5
- UL-xxxM-108, xxx= 275 to 315 in step of 5
- UL-xxxM-96, xxx= 245 to 275 in step of 5
- UL-xxxM-144, xxx= 420 to 460 in step of 5
- UL-xxxM-120, xxx= 350 to 380 in step of 5
- UL-xxxM-108, xxx= 315 to 345 in step of 5
- UL-xxxM-96, xxx= 280 to 305 in step of 5
- UL-xxxM-156, xxx= 565 to 600 in step of 5
- UL-xxxM-144, xxx= 525 to 555 in step of 5
- UL-xxxM-132, xxx= 480 to 505 in step of 5
- UL-xxxM-120, xxx= 435 to 460 in step of 5
- UL-xxxM-108, xxx= 390 to 415 in step of 5
- UL-xxxM-96, xxx= 350 to 370 in step of 5
- UL-xxxM-132, xxx= 640 to 670 in step of 5
- UL-xxxM-120, xxx= 580 to 605 in step of 5
- UL-xxxM-108, xxx= 525 to 545 in step of 5

Half cell 1500 V DC system voltage Single Glass modules:

- UL-xxxM-144HV, xxx= 370 to 415 in step of 5
 - UL-xxxM-120HV, xxx= 305 to 345 in step of 5
 - UL-xxxM-108HV, xxx= 275 to 315 in step of 5
 - UL-xxxM-96HV, xxx= 245 to 275 in step of 5
 - UL-xxxM-144HV, xxx= 420 to 460 in step of 5
 - UL-xxxM-120HV, xxx= 350 to 380 in step of 5
 - UL-xxxM-108HV, xxx= 315 to 345 in step of 5
 - UL-xxxM-96HV, xxx= 280 to 305 in step of 5
 - UL-xxxM-156HV, xxx= 565 to 600 in step of 5
 - UL-xxxM-144HV, xxx= 525 to 555 in step of 5
 - UL-xxxM-132HV, xxx= 480 to 505 in step of 5
 - UL-xxxM-120HV, xxx= 435 to 460 in step of 5
 - UL-xxxM-108HV, xxx= 390 to 415 in step of 5
 - UL-xxxM-96HV, xxx= 350 to 370 in step of 5
 - UL-xxxM-132HV, xxx= 640 to 670 in step of 5
 - UL-xxxM-120HV, xxx= 580 to 605 in step of 5
 - UL-xxxM-108HV, xxx= 525 to 545 in step of 5
- xxx is standing for rated output power at STC



Product Service

Attestation of Conformity

No. N8A 083334 0063 Rev. 08

Parameters:

Construction:	Framed, with Junction box, Cable and connectors.
Test Laboratory:	Yangzhou Opto-Electrical Products Testing Institute No.10 West Kaifa Road, Yangzhou 225009 Jiangsu, P.R.China.
Safety Class:	Class II
Max. system voltage:	1000 V DC or 1500 V DC
Fire Safety Class:	Class C according to UL790

Tested according to:

EN IEC 61730-1:2018
 EN IEC 61730-1:2018/AC:2018-06
 EN IEC 61730-2:2018
 EN IEC 61730-2:2018/AC:2018-06



Product Service

CERTIFICATE

No. Z2 083334 0048 Rev. 12

Holder of Certificate: **Ningbo Ulica Solar Co., Ltd.**

NO.181-197, Shanshan Road
Wangchun Industrial District
315177 Ningbo
PEOPLE'S REPUBLIC OF CHINA

Certification Mark:



Product:

Crystalline Silicon Terrestrial Photovoltaic (PV) Modules
Mono-Crystalline Silicon Photovoltaic Module

The product was tested on a voluntary basis and complies with the essential requirements. The certification mark shown above can be affixed on the product. It is not permitted to alter the certification mark in any way. In addition, the certification holder must not transfer the certificate to third parties. This certificate is valid until the listed date, unless it is cancelled earlier. All applicable requirements of the testing and certification regulations of TÜV SÜD Group have to be complied. For details see: www.tuvsud.com/ps-cert

Test report no.: 704061806602-12

Valid until: 2027-08-24

Date, 2022-09-05

(Zhulin Zhang)

CERTIFICATE

No. Z2 083334 0048 Rev. 12

Model(s):

1000 V DC system voltage Single Glass modules:

- UL-xxxM-72, xxx= 330 to 390 in step of 5
- UL-xxxM-60, xxx= 275 to 325 in step of 5
- UL-xxxM-54, xxx= 245 to 290 in step of 5
- UL-xxxM-48, xxx= 220 to 260 in step of 5
- UL-xxxM-24, xxx= 110 to 130 in step of 5

1500 V DC system voltage Single Glass modules:

- UL-xxxM-72HV, xxx= 330 to 390 in step of 5
- UL-xxxM-60HV, xxx= 275 to 325 in step of 5
- UL-xxxM-54HV, xxx= 245 to 290 in step of 5
- UL-xxxM-48HV, xxx= 220 to 260 in step of 5
- UL-xxxM-24HV, xxx= 110 to 130 in step of 5

Half cell 1000 V DC system voltage Single Glass modules:

- UL-xxxM-144, xxx= 370 to 415 in step of 5
- UL-xxxM-120, xxx= 305 to 345 in step of 5
- UL-xxxM-108, xxx= 275 to 315 in step of 5
- UL-xxxM-96, xxx= 245 to 275 in step of 5
- UL-xxxM-144, xxx= 420 to 460 in step of 5
- UL-xxxM-120, xxx= 350 to 380 in step of 5
- UL-xxxM-108, xxx= 315 to 345 in step of 5
- UL-xxxM-96, xxx= 280 to 305 in step of 5
- UL-xxxM-156, xxx= 565 to 600 in step of 5
- UL-xxxM-144, xxx= 525 to 555 in step of 5
- UL-xxxM-132, xxx= 480 to 505 in step of 5
- UL-xxxM-120, xxx= 435 to 460 in step of 5
- UL-xxxM-108, xxx= 390 to 415 in step of 5
- UL-xxxM-96, xxx= 350 to 370 in step of 5
- UL-xxxM-132, xxx= 640 to 670 in step of 5
- UL-xxxM-120, xxx= 580 to 605 in step of 5
- UL-xxxM-108, xxx= 525 to 545 in step of 5

Half cell 1500 V DC system voltage Single Glass modules:

- UL-xxxM-144HV, xxx= 370 to 415 in step of 5
 - UL-xxxM-120HV, xxx= 305 to 345 in step of 5
 - UL-xxxM-108HV, xxx= 275 to 315 in step of 5
 - UL-xxxM-96HV, xxx= 245 to 275 in step of 5
 - UL-xxxM-144HV, xxx= 420 to 460 in step of 5
 - UL-xxxM-120HV, xxx= 350 to 380 in step of 5
 - UL-xxxM-108HV, xxx= 315 to 345 in step of 5
 - UL-xxxM-96HV, xxx= 280 to 305 in step of 5
 - UL-xxxM-156HV, xxx= 565 to 600 in step of 5
 - UL-xxxM-144HV, xxx= 525 to 555 in step of 5
 - UL-xxxM-132HV, xxx= 480 to 505 in step of 5
 - UL-xxxM-120HV, xxx= 435 to 460 in step of 5
 - UL-xxxM-108HV, xxx= 390 to 415 in step of 5
 - UL-xxxM-96HV, xxx= 350 to 370 in step of 5
 - UL-xxxM-132HV, xxx= 640 to 670 in step of 5
 - UL-xxxM-120HV, xxx= 580 to 605 in step of 5
 - UL-xxxM-108HV, xxx= 525 to 545 in step of 5
- xxx is standing for rated output power at STC



CERTIFICATE

No. Z2 083334 0048 Rev. 12

Parameters:

Construction:	Framed, with Junction box, Cable and Connectors.
Fire Safety Class:	Class C according to UL790
Test Laboratory:	Yangzhou Opto-Electrical Products Testing Institute; No. 10 West Kaifa Road, Yangzhou 225009 Jiangsu, P. R. China
Safety Class:	Class II
Maximum System Voltage:	1000 V DC or 1500 V DC

**Tested
according to:**

IEC 61215-1:2016
IEC 61215-1-1:2016
IEC 61215-2:2016
IEC 61730-1:2016
IEC 61730-2:2016



LAPI LABORATORIO PREVENZIONE INCENDI S.p.A.
 Sede Primaria: I-59100 PRATO - Via della Quercia, 11
 Telefono +39 0574.575.320 - Telefax +39 0574.575.323
 Sede Secondaria: I-50041 CALENZANO (FI) - Via Petrarca, 48
 e-mail: lapi@laboratoriolapi.it
 web site: www.laboratoriolapi.it

Reg. 305/2011
 Notified Body N°0987

ATTESTAZIONE DI CLASSIFICAZIONE N. 094/26 DEL COMPORTAMENTO AL FUOCO DI PANNELLI FOTOVOLTAICI SECONDO LA LINEA GUIDA FOTOVOLTAICO DCPREV. 0014030 del 01/09/25
Classification Attestation n. 094/26 of the fire behaviour of photovoltaic panels according to the photovoltaic guideline DCPREV. 0014030 of 01/09/25



Richiedente - Produttore / Sponsor - Manufacturer
Ningbo Ulica Solar Co., Ltd.

No.238 Yunlin Road, Wangchun Industrial Area, Haishu District, 315177 Ningbo (P.R. China)

Denominazione del modulo sottoposto a prova / Denomination of the module submitted to test
UL-xxxM-144ADGN

Dichiarazione del Richiedente / Declaration by the Sponsor

Tutte le serie e/o i modelli riportati in allegato sono realizzati con i medesimi componenti, danno luogo alla medesima campionatura di prova e differiscono tra loro unicamente per forma e/o dimensione e/o colore.
All the series and / or the models reported in the annex are fabricated with the same components, yield the same sampling for testing and differ only for the shape and / or the dimension and / or the colour.

Norme di riferimento / Reference standards:

EN 13501-5	CEN/TS 1187-1
EN 13501-1	EN ISO 11925-2

CEN/TS 1187-1 Condizioni di prova / Test conditions Inclinazione / Pitch : 15° e / and 45°		EN 11925-2	
Risultati ottenuti Results obtained	Criteri di superamento applicabili Applicable pass criteria	Risultati ottenuti Results obtained	Criteri di super. applicabili Applicable pass criteria
Propagazione interna / esterna del fuoco verso l'alto: 0 m <i>Internal / external upward fire propagation</i>	< 0.700 m	Propagazione della fiamma al riferimento a 150 mm: Non rilevata <i>Flame propagation at 150 - mm mark: Not observed</i>	La fiamma non deve raggiungere il riferimento a 150 mm entro 30 s <i>The flame must not reach the 150 - mm mark within 30 s</i>
Propagazione interna / esterna del fuoco verso il basso: 0 m <i>Internal / external downward fire propagation</i>	< 0.600 m		
Lunghezza massima bruciata interna / esterna: 0 m <i>Maximum internal/external burn length</i>	< 0.800 m		
Gocce o pezzi accesi che cadono dalla faccia esposta: no <i>Drops or burning pieces falling from the exposed face</i>	Nessuna / None	Caduta pezzi accesi: Non rilevata <i>Burning debris fall: Not observed</i>	Non deve verificarsi caduta di pezzi accesi <i>Flaming debris fall must not occur</i>
Propagazione laterale: non osservata / <i>Lateral propagation: not observed</i>	< margini / edges		
Penetrazione del fuoco da particelle incandescenti o fiamme: no <i>Fire penetration by incandescent particles or flames</i>	Nessuna / None		
Aperture singole: non osservate / <i>Single openings: not observed</i>	< 2,5 mm ²		
Somma delle aperture / <i>Sum of openings</i> : 0 mm	< 4500 mm ²		
Combustione incandescente interna / <i>Internal incandescent combustion</i> : no	Nessuna / None		
Raggio max. propagazione fiamma (tetto orizzontale): Interno / esterno: N/A <i>Maximum flame propagation radius (horizontal roof): Internal / external</i>	< 0,200 m		

Tutti i criteri di superamento applicabili richiesti per la classificazione E secondo la norma **EN 13501-1** e **B_{ROOF}(t1)** secondo la norma **EN 13501-5** sono stati soddisfatti.

All the pass criteria applicable for the E classification according to the standard EN 13501-1 and B_{ROOF}(t1) according to the standard EN 13501-5 have been satisfied.

Prato, 13/02/2026

Il Responsabile Certificazione
 The Certification Manager

Il Direttore del Laboratorio
 The Director of the Laboratory

Validità / Valid until: 12/02/2031

[Signature]
 David Borsari

[Signature]
 Lada Ermini

Nota: Il presente documento perderà di validità a seguito di qualsiasi variazione inerente i componenti dei materiali, la denominazione commerciale, i dati del Richiedente, le modalità e/o luogo di produzione, aggiornamento normativo, ecc. Sarà cura dell'interessato richiedere un aggiornamento del documento. Infine, si ricorda che, se non esplicitamente indicato nello Standard di Prodotto a cui le prove si riferiscono, i Rapporti di Prova non hanno scadenza. Il Laboratorio potrà richiedere al rinnovo della Attestazione una verifica sperimentale per la conferma dei risultati ottenuti.

Note: This document will lose validity as a result of any changes regarding the components of the materials, the trade name, the data of the Sponsor, mode and/or place of production, regulation updates, as on so. It will be care of the Applicant to require an update of the document. Please note that, if not explicitly stated in the Product Standard to which the tests relate, the Test Reports do not expire. The Laboratory may request at the renewal of the Attestation a verification to confirm the results obtained.

Questo documento deve essere letto congiuntamente ai Rapporti di Prova e all'allegato, per la descrizione del prodotto e per ogni altra notizia di dettaglio. Questo documento non costituisce approvazione di tipo né certificazione di prodotto né tantomeno dichiarazione di conformità, che spetta esclusivamente al Produttore / Sponsor.

This document has to be read in conjunction with the Test Reports, for the description of the product and for every other detail. This document does not represent type approval or certification of the product neither declaration of compliance, that is exclusively under the responsibility of the Manufacturer or Sponsor.





LAPI LABORATORIO PREVENZIONE INCENDI S.p.A.
 Sede Primaria: I-59100 PRATO - Via della Quercia, 11
 Telefono +39 0574.575.320 - Telefax +39 0574.575.323
 Sede Secondaria: I-50041 CALENZANO (FI) - Via Petrarca, 48
 e - mail: lapi@laboratoriolapi.it
 web site: www.laboratoriolapi.it

Reg. 305/2011
Notified Body N°0987

ALLEGATO AD ATTESTAZIONE DI CLASSIFICAZIONE / ANNEX TO CLASSIFICATION ATTESTATION
No. 094/26

Richiedente - Produttore / Sponsor - Manufacturer

Ningbo Ulica Solar Co., Ltd.

No.238 Yunlin Road, Wangchun Industrial Area, Haishu District, 315177 Ningbo (P.R. China)

Denominazione del modulo sottoposto a prova / Denomination of the module submitted to test
UL-xxxM-144ADGN

Lista dei moduli ai quali si applica la classificazione No. 094/26
List of the modules to which the classification No. 094/26 applies



No.	Modulo / Module	Front + Back side	Module size (mm)	No.	Modulo / Module	Front + Back side	Module size (mm)
1	UL-xxxM-156ADGN	Glass + Glass	2465*1134*30/35	14	UL-xxxM-132CDGN	Glass + Glass	2188*1134*30
2	UL-xxxM-144ADGN	Glass + Glass	2278*1134*30/35	15	UL-xxxM-120CDGN	Glass + Glass	1994*1134*30
3	UL-xxxM-132ADGN	Glass + Glass	2094*1134*30/35	16	UL-xxxM-108CDGN	Glass + Glass	1800*1134*30
4	UL-xxxM-120ADGN	Glass + Glass	1909*1134*30/35	17	UL-xxxM-96CDGN	Glass + Glass	1606*1134*30
5	UL-xxxM-108ADGN	Glass + Glass	1722*1134*30/35	18	UL-xxxM-132DDGN	Glass + Glass	2382*1134*30
6	UL-xxxM-96ADGN	Glass + Glass	1539*1134*30/35	19	ULQ-xxxM-132DDGN	Glass + Glass	2382*1134*30
7	UL-xxxM-156BDGN	Glass + Glass	2523*1134*30	20	UL-xxxM-120DDGN	Glass + Glass	2170*1134*30
8	UL-xxxM-144BDGN	Glass + Glass	2333*1134*30	21	UL-xxxM-108DDGN	Glass + Glass	1961*1134*30
9	UL-xxxM-132BDGN	Glass + Glass	2142*1134*30	22	UL-xxxM-96DDGN	Glass + Glass	1762*1134*30
10	UL-xxxM-120BDGN	Glass + Glass	1952*1134*30	23	UL-xxxM-132DGN	Glass + Glass	2384*1303*35/33
11	UL-xxxM-108BDGN	Glass + Glass	1762*1134*30	24	UL-xxxM-120DGN	Glass + Glass	2172*1303*35/33
12	UL-xxxM-96BDGN	Glass + Glass	1573*1134*30	25	UL-xxxM-108DGN	Glass + Glass	1960*1303*35/30
13	UL-xxxM-144CDGN	Glass + Glass	2382*1134*30	26	UL-xxxM-96DGN	Glass + Glass	1748*1303*30

Il Richiedente dichiara che tutte le serie e/o i modelli riportati in allegato sono realizzati con i medesimi componenti, danno luogo alla medesima campionatura di prova e differiscono tra loro unicamente per forma e/o dimensione e/o colore.

The Sponsor declares that all the series and / or the models reported in the annex are fabricated with the same components, yield the same sampling for testing and differ only for the shape and / or the dimension and / or the colour.

Prato, 13/02/2026

Il Responsabile Certificazione
The Certification Manager

Il Direttore del Laboratorio
The Director of the Laboratory

Validità / Valid until: 12/02/2031

David Borsini

Luca Ermini

Il presente documento non può essere riprodotto in forma parziale senza l'autorizzazione scritta di LAPI S.p.A.

DOUBLE-GLASS BIFACIAL N-TYPE 445~455 Watt



TOPCon

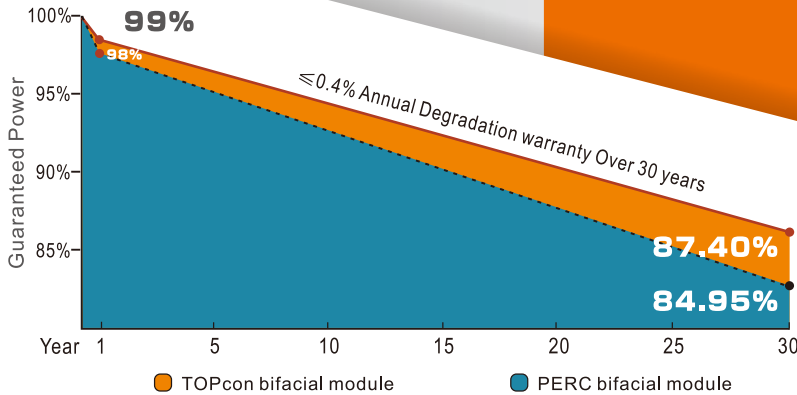

Cutting Free Technology
Minimized micro-crack



Bifacial Mono Module
Capable of generating power at back side, at least 80% efficiency of the front side



Anti-PID (potential induced degradation)
Passed anti-PID test under 85°C damp heat 85% relative humidity for 192 hours



Lower LCOE
Lower shading and resistive loss
Lower temperature coefficient



Outstanding mechanical load resistance
2400 Pa wind load, 5400 Pa snow load



15 15-year product warranty
30 30-year linear power output



CEC Listed



IEC 61215, IEC 61730
ISO 9001: 2015 (Quality management systems)
ISO 14001: 2015 (Environmental management systems)
ISO 45001: 2018 (Occupational health and safety)
UNI 9177 Ia CLASSE DI REAZIONE AL FUOCO:1



Add: No.238 Yunlin Middle Road, Wangchun Industrial District, Ningbo China

Tel: +86-574-28828939 Email: sales@ulsolar.com.cn

Fax: +86-574-28828997 Web: www.ulicasolar.com

44/229

TOPCon(N TYPE) 445~455Watt

ELECTRICAL SPECIFICATIONS

Module Type		UL-445M-108BDGN		UL-450M-108BDGN		UL-455M-108BDGN	
		STC* NOCT*	STC* NOCT*	STC* NOCT*	STC* NOCT*		
Maximum Power (Pmax)	W	445	337	450	341	455	345
Maximum Power Voltage (Vmp)	V	33.02	30.38	33.22	30.56	33.42	30.75
Maximum Power Current (Imp)	A	13.48	11.10	13.55	11.16	13.61	11.21
Open-circuit Voltage (Voc)	V	39.58	36.02	39.78	36.20	39.98	36.38
Short-circuit Current (Isc)	A	14.30	11.53	14.38	11.60	14.45	11.66
Module Efficiency STC	%	22.27		22.52		22.77	
Operating Temperature		-40°C~85°C					
Maximum system voltage		DC1500V(IEC)					
Maximum series fuse rating		30A					
Power tolerance		0~+5Watt					
Temperature coefficients of Pmax		-0.29%/°C					
Temperature coefficients of Voc		-0.25%/°C					
Temperature coefficients of Isc		0.046%/°C					
Nominal operating cell temperature (NOCT)		43±2°C					

*STC : Cell temperature: 25°C, Irradiance: 1000 W/m², Air mass: 1.5G

*NOCT : Air temperature: 20°C, Irradiance: 800 W/m², Air mass: 1.5G, Wind speed: 1 m/s

I-V CURVE

I-V characteristics at different irradiances (reference to 450W)

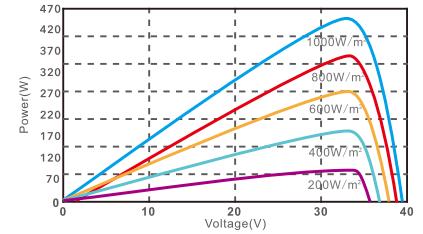
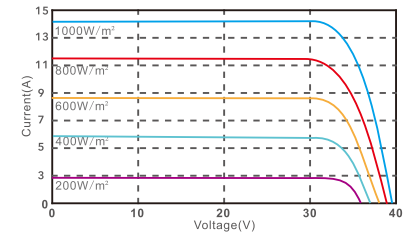

I-V characteristics at different temperature

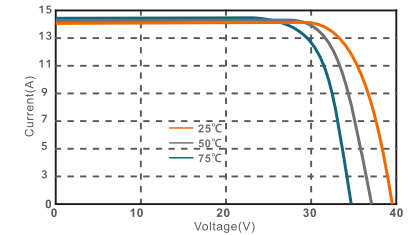

SPECIFICATIONS

Cell Type	N type Mono-crystalline
No. of cells	108(6×9×2)
Dimensions	1762*1134*30mm
Weight	24.0kg
Glass	2.0mm+2.0mm, Anti-Reflection Coating, High Transmission, Low Iron, Tempered Glass
Junction Box	IP68, 3 diodes
Connector	MC4 Compatible
Cable Length (Including Connector)	4mm ² Landscape: (+)1200mm/(-)1200mm or Customized Length
Packaging Configuration	Two Box=One Pallet 36pcs/Box, 72pcs/Pallet, 936pcs/40HQ Container

Electrical characteristics with different rear side power gain (reference to 450W front)

Pmax/W	Voc/V	Isc/A	Vmp/V	Imp/A	Pmax gain
450	39.78	14.38	33.22	13.55	0%
473	39.78	15.10	33.22	14.22	5%
495	39.78	15.82	33.22	14.90	10%
518	39.78	16.54	33.22	15.58	15%
540	39.78	17.26	33.22	16.26	20%
563	39.78	17.98	33.22	16.93	25%
585	39.78	18.69	33.22	17.61	30%

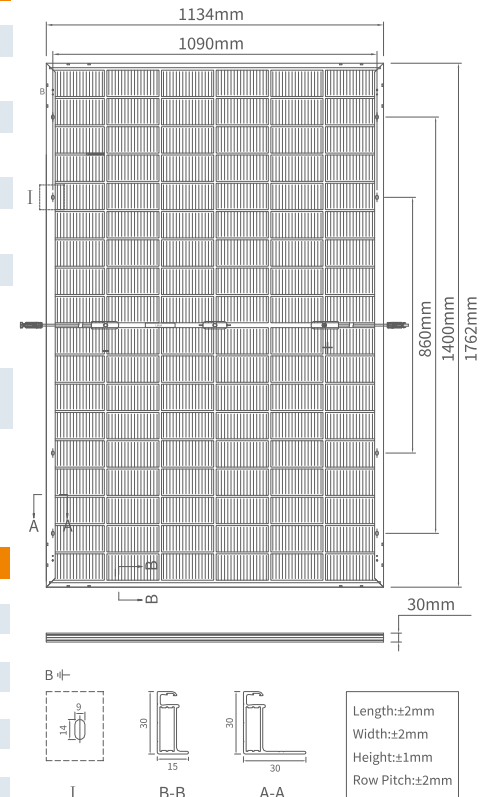

Specifications included in this datasheet are subject to change without notice.

Ulica Solar reserves the right of final interpretation.

Version No.: UL-1762-108BDGNBBC-30-EN-V1.2

DOUBLE-GLASS BIFACIAL N-TYPE 575~590Watt

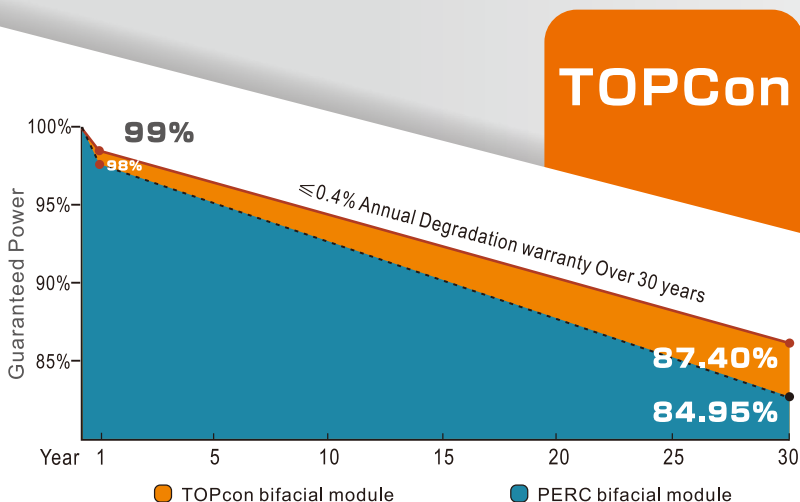

Bifacial Mono Module

Capable of generating power at back side, at least 80% efficiency of the front side



Anti-PID (potential induced degradation)

Passed anti-PID test under 85°C damp heat 85% relative humidity for 192 hours



Great Durability against extreme conditions

Passed salt mist corrosion test, ammonia corrosion test, dust & sand test, fire test, all certified by TÜV



Lower LCOE

Lower shading and resistive loss
Lower temperature coefficient



Outstanding mechanical load resistance

2400 Pa wind load, 5400 Pa snow load



15 15-year product warranty

30 30-year linear power output



CEC Listed



IEC 61215, IEC 61730

ISO 9001: 2015 (Quality management systems)

ISO 14001: 2015 (Environmental management systems)

ISO 45001: 2018 (Occupational health and safety)

UNI 9177 la CLASSE DI REAZIONE AL FUOCO: 1



Add: No. 238 Yunlin Middle Road, Wangchun Industrial District, Ningbo China

Tel: +86-574-28828939

Email: sales@ulsolar.com.cn

Fax: +86-574-28828997

Web: www.ulicasolar.com

46/229

ELECTRICAL SPECIFICATIONS

Module Type	UL-575M-144ADGN		UL-580M-144ADGN		UL-585M-144ADGN		UL-590M-144ADGN		
	STC*	NOCT*	STC*	NOCT*	STC*	NOCT*	STC*	NOCT*	
Maximum Power (Pmax)	W	575	436	580	440	585	443	590	447
Maximum Power Voltage (Vmp)	V	43.85	40.34	44.02	40.50	44.17	40.64	44.35	40.80
Maximum Power Current (Imp)	A	13.11	10.80	13.18	10.85	13.24	10.91	13.30	10.96
Open-circuit Voltage (Voc)	V	52.32	47.61	52.52	47.79	52.72	47.98	52.82	48.07
Short-circuit Current (Isc)	A	13.89	11.20	13.95	11.25	14.01	11.30	14.02	11.31
Module Efficiency STC	%	22.26		22.45		22.65		22.84	
Operating Temperature	-40°C~85°C								
Maximum system voltage	DC1500V(IEC)								
Maximum series fuse rating	30A								
Power tolerance	0~+5Watt								
Temperature coefficients of Pmax	-0.29%/°C								
Temperature coefficients of Voc	-0.25%/°C								
Temperature coefficients of Isc	0.046%/°C								
Nominal operating cell temperature (NOCT)	43±2°C								

*STC : Cell temperature: 25°C, Irradiance: 1000 W/m², Air mass: 1.5G

*NOCT : Air temperature: 20°C, Irradiance: 800 W/m², Air mass: 1.5G, Wind speed: 1 m/s

I-V CURVE

I-V characteristics at different irradiances (reference to 580 W)

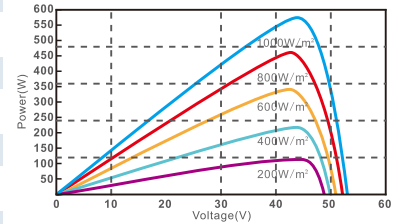
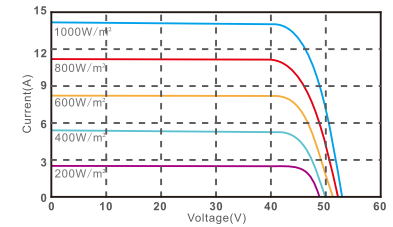

I-V characteristics at different temperature

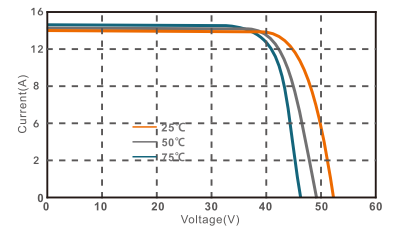

SPECIFICATIONS

Cell Type	N type Mono-crystalline	
No. of cells	144(6×12×2)	
Dimensions	2278*1134*30mm	
Weight	30.6kg	
Glass	2.0mm+2.0mm, Anti-Reflection Coating, High Transmission, Low Iron, Tempered Glass	
Junction Box	IP68, 3 diodes	
Connector	MC4 Compatible	
Cable Length (including Connector)	4mm ² Landscape:(+)1400mm/(-)1400mm or Customized Length	
Packaging Configuration	Two Box=One Pallet 36pcs/Box, 72pcs/Pallet, 720pcs/40HQ Container	

Electrical characteristics with different rear side power gain (reference to 580 W front)

Pmax/W	Voc/V	Isc/A	Vmp/V	Imp/A	Pmax gain
580	52.52	13.95	44.02	13.18	0%
609	52.52	14.65	44.02	13.83	5%
638	52.52	15.35	44.02	14.49	10%
667	52.52	16.04	44.02	15.15	15%
696	52.52	16.74	44.02	15.81	20%
725	52.52	17.44	44.02	16.47	25%
754	52.52	18.14	44.02	17.13	30%

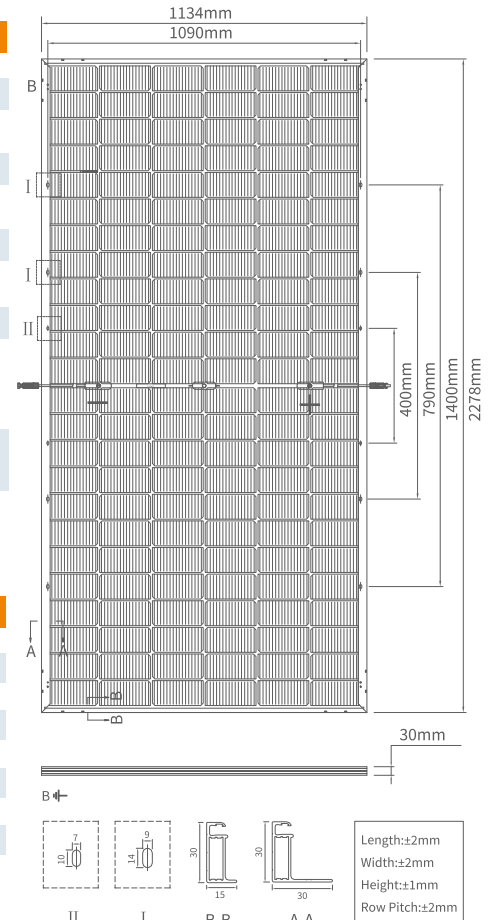

Specifications included in this datasheet are subject to change without notice.

Ulica Solar reserves the right of final interpretation.

Version No.: UL-2278-144ADGNBBC-30-EN-V1.2



LAPI LABORATORIO PREVENZIONE INCENDI S.p.A.
Sede Primaria: I-59100 PRATO - Via della Quercia, 11
Telefono +39 0574.575.320 - Telefax +39 0574.575.323
Sede Secondaria: I-50041 CALENZANO (FI) - Via Petrarca, 48
e-mail: lapi@laboratoriolapi.it
web site: www.laboratoriolapi.it

CERTIFICATO DI PROVA N. 7797/A

Emesso ai sensi dell'art. 10 del decreto del Ministero dell'interno del 26 giugno 1984 concernente "Classificazione di reazione al fuoco ed omologazione dei materiali ai fini della prevenzione incendi" modificato con decreto del Ministero dell'interno del 03 settembre 2001 (G.U. n° 242 del 17 ottobre 2001).

Visto l'esito degli accertamenti effettuati si certifica che alla
INSTALLAZIONE TECNICA (Allegato A.2.1)

Prodotto da: **ULICA SOLAR**

Denominato: **UL-xxxM-108HV**

Codice di identificazione: **L/7797/A/2022**

Impiegato come: **PANNELLO FOTOVOLTAICO**

è attribuita in conformità alla UNI 9177 la **CLASSE DI REAZIONE AL FUOCO: 1**

Il presente Certificato è valido unicamente per la campionatura sottoposta a prova.

Costituiscono parte integrante del presente Certificato n. 4 allegati.

Prato, 18/07/2022

Il Direttore del Laboratorio
Dr. Luca Ermini



Rapporto di prova n° **L 7797/A/1****UNI 8457 (1987) - UNI 8457/A1 (1996)**Allegato al certificato n° **L 7797/A**Materiale: **Isotropo**Posa in opera: **non in aderenza a supporto incombustibile**

Provetta n°	Tempo di post-combustione [s]	Tempo di post-incandescenza [s]	Zona danneggiata [mm]	Gocciolamento
1	0	0	25	assente
2	0	0	20	assente
3	0	0	25	assente
4	0	0	20	assente
5	0	0	25	assente
6	0	0	25	assente
7	0	0	25	assente
8	0	0	20	assente
9	0	0	20	assente
10	0	0	25	assente

Metodo di preparazione UNI 9176 (1998): **D**

	Valore medio	Livello	CATEGORIA I
Tempo di post-combustione [s]	0	1	
Tempo di post-incandescenza [s]	0	1	
Zona danneggiata [mm]	23	1	
Gocciolamento	assente	1	

Note:

- LATO ESPOSTO: LATO BACKSHEET -

LSP SpALABORATORIO PREVENZIONE INCENDI
Legalmente riconosciuto - Autorizzato dal Ministero dell'Interno

Data prova

30/06/2022

L'Operatore

Rapporto di prova n° L 7797/A/2											METODO DI PROVA UNI 9174 (1987) - UNI 9174/A1 (1996)							
Allegato al Certificato n° L 7797/A																		
Materiale: Isotropo																		
			100	150	200	250	300	350	400	450	500	550	600	650	700	750	800	
Tempo (in secondi) per raggiungere la distanza di mm	Provetta n°	1	670															
		2	590															
		3	650															
Velocità media di propagazione della fiamma in mm/s	Provetta n°	1	//															
		2	//															
		3	//															
	Velocità di propagazione [mm/min]		Zona danneggiata [mm]				Tempo di post-incandescenza [s]		Gocciolamento									
		valore	livello	valore	livello	valore	livello	valore	livello	valore	livello							
Provetta n°	1	N.D.	1	100	1	N.D.	1	assente	1									
	2	N.D.	1	100	1	N.D.	1	assente	1									
	3	N.D.	1	100	1	N.D.	1	assente	1									
Metodo di preparazione UNI 9176 (1998): D											CATEGORIA I							
Posizione: Parete																		
Posa in opera: non in aderenza a supporto incombustibile																		
Note:																		
- LATO ESPOSTO: LATO BACKSHEET -																		
Legenda - N.D.: Non Determinabile - La velocità di propagazione della fiamma è <u>non determinabile</u> quando la fiamma non raggiunge i 150 mm - Il tempo di post-incandescenza è <u>non determinabile</u> quando la fiamma non raggiunge i 300 mm																		
 LABORATORIO PREVENZIONE INCENDI Legalmente riconosciuto - Autorizzato dal Ministero dell'Interno											Data prova 30/06/2022		L'Operatore 					

ALLEGATO A)
scheda tecnica
MODELLO C

Allegato al Certificato di
Reazione al Fuoco

7797A 18LUG2022

LAPI S.p.A.

Laboratorio Prevenzione Incendi

A) AZIENDA PRODUTTRICE:

ULICA SOLAR COLUMBUS WEG 10
5928 LC VENLO NETHERLAND

B) DENOMINAZIONE COMMERCIALE DEL MATERIALE: ... UL-xxxM-108HV

C) DESCRIZIONE DEL MATERIALE: PANNELLO FOTOVOLTAICO

C.1) **Natura dei componenti:**

1° STRATO : vetro TEMPERATO PRODOTTO DALLA HENAN ANCAI HI-TECH (spessore 3.2 mm)

2° STRATO : EVA F406P (spessore 1 mm)

3° STRATO : CELLE MONOCRISTALLINE (spessore 0.18 mm)

4° STRATO : EVA F406P (spessore 1 mm)

5° STRATO : backsheet in COSTITUITO da 3 strati di materiali.

Polimero Fluorurato (25 micron) FFC, prodotto dalla Crown Advanced Materials Co.,Ltd

PET(250micron) NYS20 prodotto dalla Crown Advanced Materials Co.,Ltd.

Polimero Fluorurato(15 micron) FFC, prodotto dalla Crown Advanced Materials Co.,Ltd Tipo Crown
Advanced Materials Co.,Ltd. (spessore ...0.35.. mm)

C.2) **Formato:** (lunghezza, larghezza, spessore):

...1722...x...1134...x...5.73 mm

C.3) **Pesi:**

1° STRATO : ...7.81... kg/m2

2° STRATO : ...0.89...Kg/m2

3° STRATO : ...0.38... Kg/m2

4° STRATO : ...0.89... Kg/m2

5° STRATO : ...0.33... Kg/m2

PESO TOTALE: 10.3 kg/m2 .

C.4) **Lavorazione: LAMINAZIONE**

Il materiale è ISOTROPO A FACCE DIVERSE

D) ASSIEMAGGIO DEI DIVERSI COMPONENTI: **LAMINAZIONE**

E) POSA IN OPERA: NON IN ADERENZA A SUPPORTO INCOMBUSTIBILE

F) IMPIEGO:**PANNELLO FOTOVOLTAICO**

G) MANUTENZIONE: metodo D UNI 9176/98

Data, ...2022-3-30.....

Firma (il Legale Rappresentante)



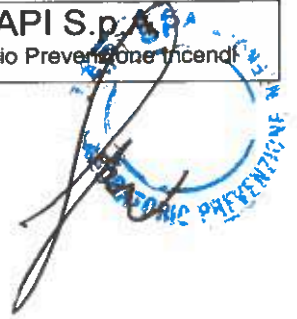

ALLEGATO D)
DICHIARAZIONE SOSTITUTIVA DI ATTO NOTORIO
MODELLO D.13

(art. 47 del d.P.R. 28/12/2000 n° 445)

Il sottoscritto (1) (cognome e nome) Wang Minglai
nato a (luogo) Venlo il (data di nascita) 26th Oct 1962, residente
(indirizzo di residenza) Columbusweg, documento di identità 330227196210262055
n. _____ rilasciato da _____, nella sua qualità di

Wang Minglai (titolare, legale rappresentante, amministratore) della
Ulica Solar (2) (ragione sociale ditta, impresa, ente,
società), con sede legale in (indicare indirizzo, numero di telefono e PEC)

Columbusweg 10, 5928 LC Venlo, Netherlands, PIVA NL825858598B01

consapevole che in caso di dichiarazione mendace sarà punito ai sensi del codice penale secondo quanto prescritto dall'art. 76 del succitato d.P.R. 445/2000 e che, inoltre, qualora dal controllo effettuato emerga la non veridicità del contenuto di taluna delle dichiarazioni rese, decadrà dai benefici conseguenti al provvedimento eventualmente emanato sulla base della dichiarazione non veritiera (art. 75 d.P.R. 445/2000), con riferimento al prodotto denominato
“ UL-xxxM-108HV ”

dichiara

sotto la propria responsabilità civile e penale, che per l'intera realizzazione di una delle superfici del materiale denominato (3) ...UL-xxxM-108HV....., è utilizzato il seguente componente (4) ... VETRO TEMPERATO...rientra nell'elenco dei materiali di cui all'art 1 del DM 14.01.1985 (G.U. n. 16 del 19.01.1985) (5)

Data,**2022-3-30**.....

Firma del Legale Rappresentante

- 1) richiedente la certificazione
- 2) la ditta intestataria della certificazione
- 3) il materiale per il quale si richiede la certificazione
- 4) riportare la descrizione del componente così come indicata nella scheda tecnica del materiale
- 5) riportare la dicitura d'interesse:
 - a) rientra nell'elenco dei materiali di cui all'art 1 del DM 14.01.1985 (G.U. n. 16 del 19.01.1985)
 - b) risulta essere di classe 0 (zero) come da atto di omologazione (riportare gli estremi dell'atto: produttore, numero di codice, data di emissione).

HORAY

HORAY



455W

HORAY

TIER1
BloombergNEF

HS **186R-108** TC-D *Alpine* N-type Bifacial Modules



SMBB Half-Cell Technology

More uniform current collection capability, reducing the current heat loss of the internal cells.



Higher Output Power

The output power of 108 half-cells monocrystalline modules is up to 455W.



Low Light Features

Higher performance under low light environment.



Harsh Environmental Adaptability

Strict salt spray and ammonia corrosion test by the third party.



N-type With Very Low LID

N-type solar cell has very low LID naturally which can reduce power degradation.

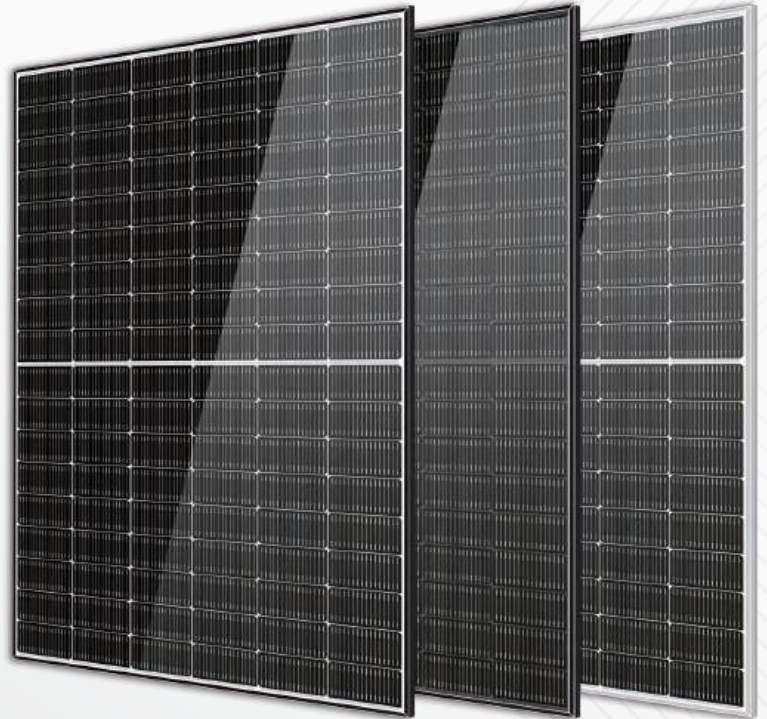

IEC61215:2021

IEC61730:2023

ISO9001:2015 Quality Management System

ISO14001:2015 Environmental Management System

IOS45001:2018 Occupational Health and Safety Management System

CE: Europe Standard

China Quality Certification Centre

Solar Product Certification

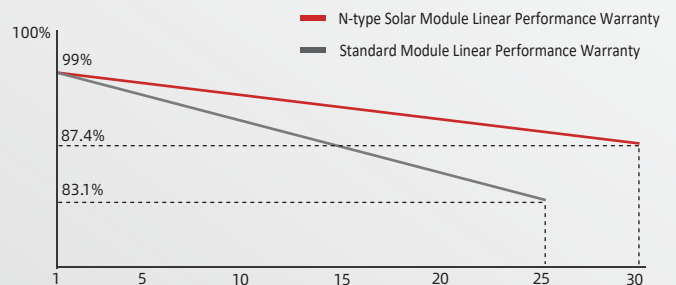
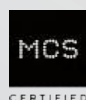

15-year product warranty



30-year linear power output warranty

HEADQUARTER: HORAY SOLAR CO., LTD.

GLOBAL MARKETING AND SERVICE: HORAY SOLAR GMBH

sales@horaysolar.com www.horaysolar.com +86-510 83580688

info@horaysolar.com www.horaysolar.com

No.300 Huiming Road, Huishan District, 214177 Wuxi, Jiangsu, P.R. China

Robert-Bosch-Straße 27-29, 63225 Langen, Germany

MECHANICAL DIAGRAMS

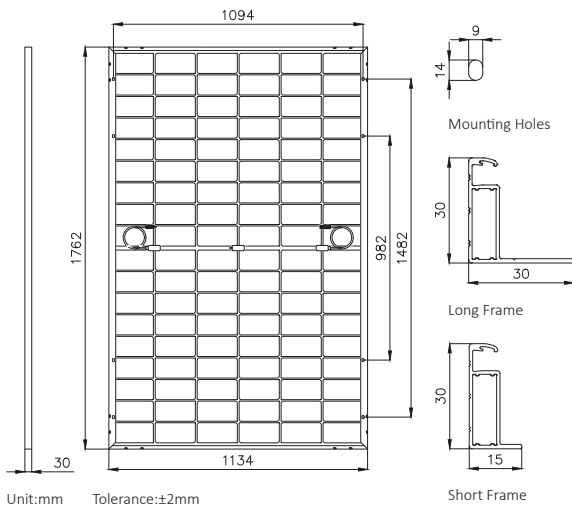

MECHANICAL PARAMETERS

Weight	24.5kg
Dimension	1762×1134×30mm
Cell Orientation	108 (6×18)
Junction Box	IP68, three diodes
Output Cable	4mm ² ,±300mm (length can be customized)
Connector	MC4 compatible
Glass	2.0+2.0mm AR coated heat strengthened glass
Frame	Anodized aluminum alloy frame
Packaging	37pcs per pallet/962pcs per 40'HC

CURVES OF PV MODULE

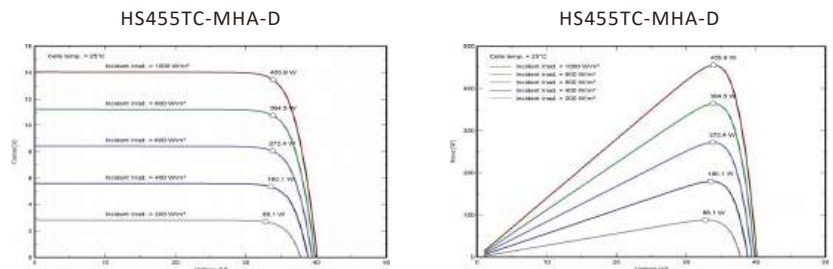

ELECTRICAL CHARACTERISTICS

Module Type	HS435TC-MHA-D		HS440TC-MHA-D		HS445TC-MHA-D		HS450TC-MHA-D		HS455TC-MHA-D	
	STC	NMOT	STC	NMOT	STC	NMOT	STC	NMOT	STC	NMOT
Maximum Power(Pmax/W)	435	331	440	335	445	339	450	343	455	347
Open Circuit Voltage(Voc/V)	39.36	39.36	39.57	39.57	39.77	39.77	39.97	39.97	40.14	40.14
Short Circuit Current(Isc/A)	13.72	10.45	13.80	10.52	13.87	10.57	13.94	10.62	14.03	10.69
Maximum Power Voltage(Vmp/V)	32.78	32.78	32.99	32.99	33.19	33.19	33.39	33.39	33.53	33.53
Maximum Power Current(Imp/A)	13.27	10.11	13.34	10.17	13.41	10.22	13.48	10.27	13.57	10.34
Module Efficiency(%)	21.8		22.0		22.3		22.5		22.8	

* Under Standard Test Conditions (STC) of irradiance of 1000 W/m², spectrum AM 1.5 and cell temperature of 25°C.

* Under Nominal Module Operating Temperature (NMOT), irradiance of 800 W/m², spectrum AM 1.5, ambient temperature 20°C, wind speed 1 m/s.

ELECTRICAL CHARACTERISTICS WITH 10% SOLAR IRRADIATION RATIO (BNPI)

Maximum Power(Pmax/W)	469	475	480	486	491
Open Circuit Voltage(Voc/V)	39.36	39.57	39.77	39.97	40.14
Short Circuit Current(Isc/A)	14.68	14.77	14.84	14.92	15.01
Maximum Power Voltage(Vmp/V)	32.78	32.99	33.19	33.39	33.53
Maximum Power Current(Imp/A)	14.32	14.40	14.47	14.55	14.64

*Rear side power gain:The additional gain from the rear side compared to the power of the front side at the standard test condition.It depends on mounting (structure,height,tilt angle etc.)and albedo of the ground.

OPERATING PARAMETERS

Operational Temperature	-40°C~+85°C
Power Output Tolerance	0~3%
Maximum System Voltage	1500V
Maximum Series Fuse Rating	25A
Nominal Operating Cell Temperature	45±2°C
Protection Class	Class II
Bifaciality	80±5%
Fire Rating	IEC Class A

*The actual test value may be slightly deviated from the technical parameters due to the difference in test methods.

MECHANICAL LOADING

Front Side Maximum Static Loading	5400Pa
Rear Side Maximum Static Loading	2400Pa
Hailstone Test	25mm Hailstone at the speed of 23m/s

TEMPERATURE RATINGS (STC)

Temperature Coefficient of Isc	+0.04%/°C
Temperature Coefficient of Voc	-0.23%/°C
Temperature Coefficient of Pmax	-0.28%/°C



510W

HORAY



HS 186R-120 TC-D Alpine N-type Bifacial Modules



SMBB Half-Cell Technology

More uniform current collection capability, reducing the current heat loss of the internal cells.



Higher Output Power

The output power of 120 half-cells monocrystalline modules is up to 510W.



Low Light Features

Higher performance under low light environment.



Harsh Environmental Adaptability

Strict salt spray and ammonia corrosion test by the third party.



N-type With Very Low LID

N-type solar cell has very low LID naturally which can reduce power degradation.

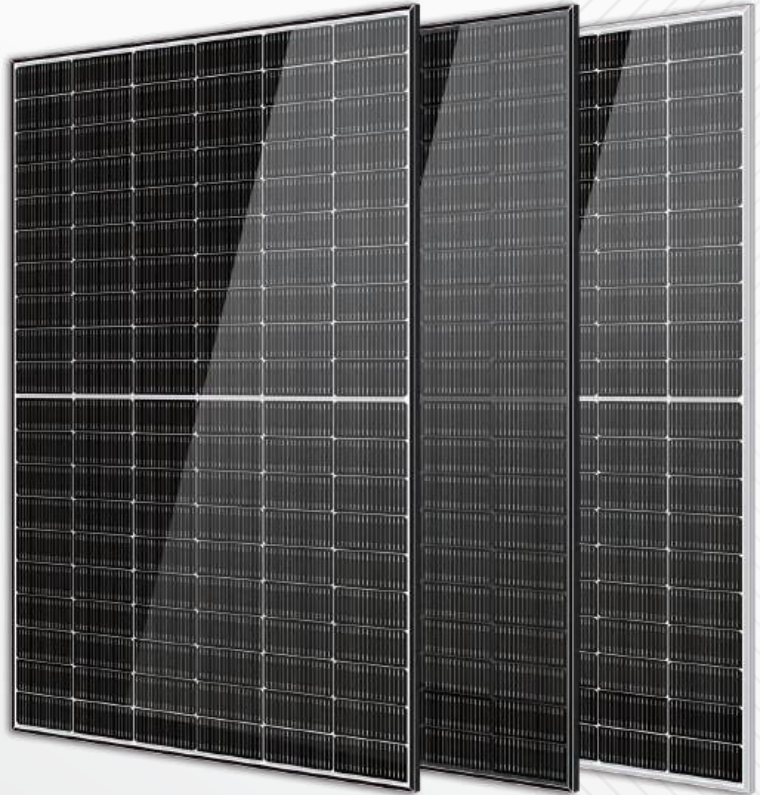

IEC61215:2021

IEC61730:2023

ISO9001:2015 Quality Management System

ISO14001:2015 Environmental Management System

IOS45001:2018 Occupational Health and Safety Management System

CE: Europe Standard

China Quality Certification Centre

Solar Product Certification

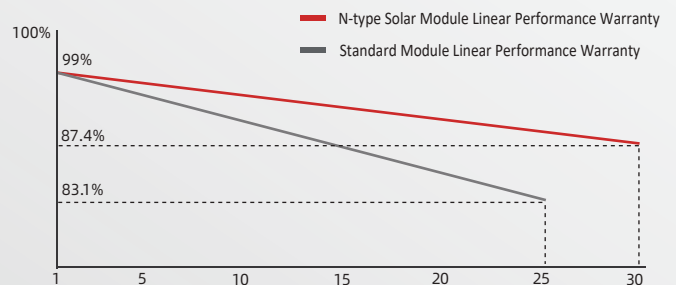
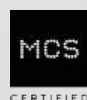

15-year product warranty



30-year linear power output warranty

HEADQUARTER: HORAY SOLAR CO., LTD.

GLOBAL MARKETING AND SERVICE: HORAY SOLAR GMBH

sales@horaysolar.com www.horaysolar.com +86-510 83580688

info@horaysolar.com www.horaysolar.com

No.300 Huiming Road, Huishan District, 214177 Wuxi, Jiangsu, P.R. China

Robert-Bosch-Straße 27-29, 63225 Langen, Germany

MECHANICAL DIAGRAMS

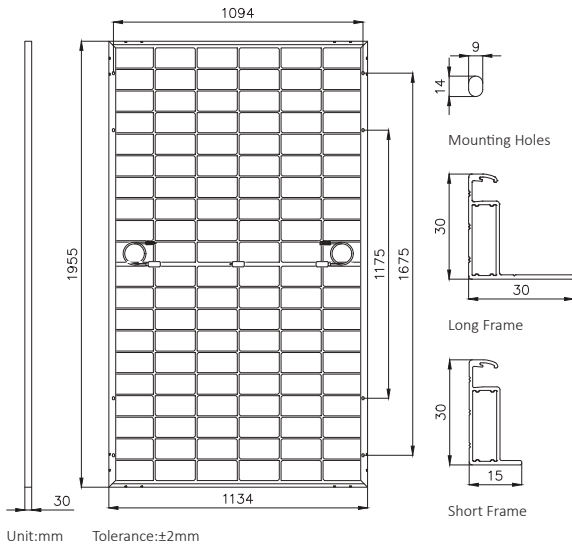

MECHANICAL PARAMETERS

Weight	26.0kg
Dimension	1955×1134×30mm
Cell Orientation	120 (6×20)
Junction Box	IP68, three diodes
Output Cable	4mm ² ,±300mm (length can be customized)
Connector	MC4 compatible
Glass	2.0+2.0mm AR coated heat strengthened glass
Frame	Anodized aluminum alloy frame
Packaging	37pcs per pallet/814pcs per 40'HC

CURVES OF PV MODULE

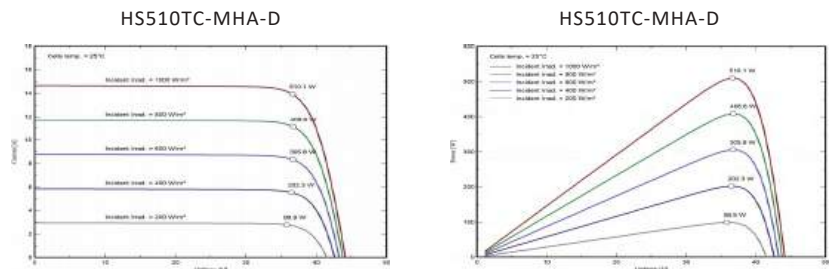

ELECTRICAL CHARACTERISTICS

Module Type	HS490TC-MHA-D		HS495TC-MHA-D		HS500TC-MHA-D		HS505TC-MHA-D		HS510TC-MHA-D	
	STC	NMOT	STC	NMOT	STC	NMOT	STC	NMOT	STC	NMOT
Maximum Power(Pmax/W)	490	373	495	377	500	381	505	385	510	389
Open Circuit Voltage(Voc/V)	43.35	43.35	43.53	43.53	43.70	43.70	43.88	43.88	44.10	44.10
Short Circuit Current(Isc/A)	14.31	10.90	14.40	10.97	14.48	11.04	14.57	11.10	14.64	11.16
Maximum Power Voltage(Vmp/V)	36.17	36.17	36.32	36.32	36.47	36.47	36.62	36.62	36.80	36.80
Maximum Power Current(Imp/A)	13.55	10.32	13.63	10.38	13.71	10.45	13.79	10.51	13.86	10.56
Module Efficiency(%)	22.2		22.4		22.6		22.9		23.1	

* Under Standard Test Conditions (STC) of irradiance of 1000 W/m², spectrum AM 1.5 and cell temperature of 25°C.

* Under Nominal Module Operating Temperature (NMOT), irradiance of 800 W/m², spectrum AM 1.5, ambient temperature 20°C, wind speed 1 m/s.

ELECTRICAL CHARACTERISTICS WITH 10% SOLAR IRRADIATION RATIO (BNPI)

Maximum Power(Pmax/W)	529	534	540	545	550
Open Circuit Voltage(Voc/V)	43.35	43.53	43.70	43.88	44.10
Short Circuit Current(Isc/A)	15.31	15.40	15.50	15.59	15.67
Maximum Power Voltage(Vmp/V)	36.17	36.32	36.47	36.62	36.80
Maximum Power Current(Imp/A)	14.62	14.71	14.80	14.89	14.96

*Rear side power gain:The additional gain from the rear side compared to the power of the front side at the standard test condition.It depends on mounting (structure,height,tilt angle etc.)and albedo of the ground.

OPERATING PARAMETERS

Operational Temperature	-40°C~+85°C
Power Output Tolerance	0~3%
Maximum System Voltage	1500V
Maximum Series Fuse Rating	25A
Nominal Operating Cell Temperature	45±2°C
Protection Class	Class II
Bifaciality	80±5%
Fire Rating	IEC Class A

*The actual test value may be slightly deviated from the technical parameters due to the difference in test methods.

MECHANICAL LOADING

Front Side Maximum Static Loading	5400Pa
Rear Side Maximum Static Loading	2400Pa
Hailstone Test	25mm Hailstone at the speed of 23m/s

TEMPERATURE RATINGS (STC)

Temperature Coefficient of Isc	+0.04%/°C
Temperature Coefficient of Voc	-0.23%/°C
Temperature Coefficient of Pmax	-0.28%/°C



560W

HORAY

TIER1
BloombergNEF

HS **186R-132** TC-D *Alpine* N-type Bifacial Modules

N-type
SMBB

SMBB Half-Cell Technology
More uniform current collection capability, reducing the current heat loss of the internal cells.

CONVERSION

Higher Output Power
The output power of 132 half-cells monocrystalline modules is up to 560W.

LOW LIGHT

Low Light Features
Higher performance under low light environment.

RESISTANT

Harsh Environmental Adaptability
Strict salt spray and ammonia corrosion test by the third party.

LID
LOW LID

N-type With Very Low LID
N-type solar cell has very low LID naturally which can reduce power degradation.

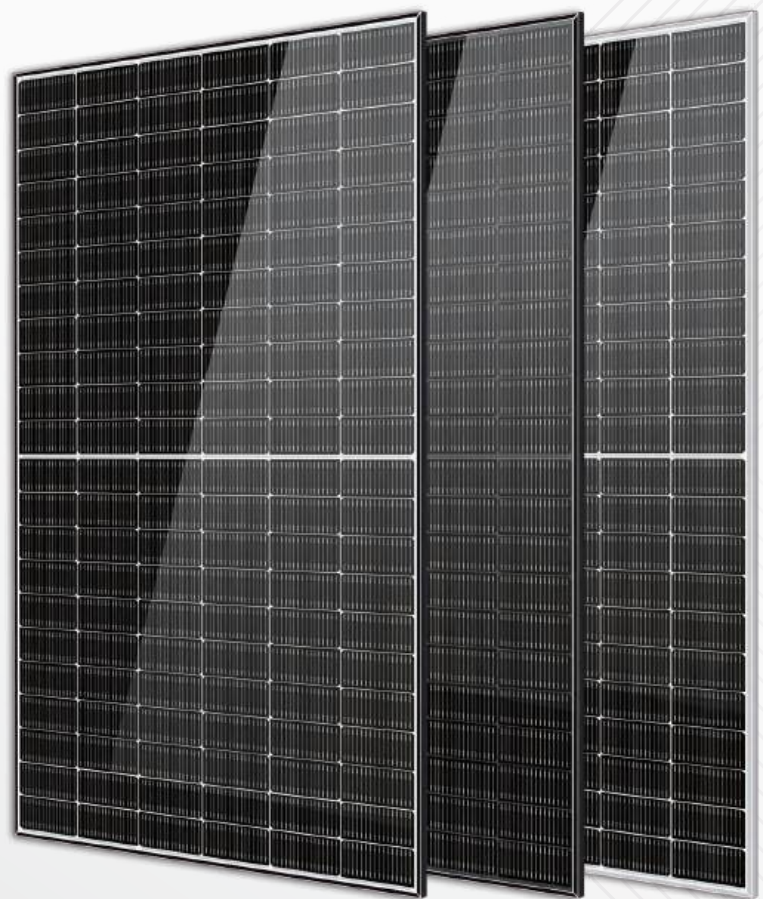

- IEC61215:2021
- IEC61730:2023
- ISO9001:2015 Quality Management System
- ISO14001:2015 Environmental Management System
- IOS45001:2018 Occupational Health and Safety Management System
- CE: Europe Standard
- China Quality Certification Centre
- Solar Product Certification

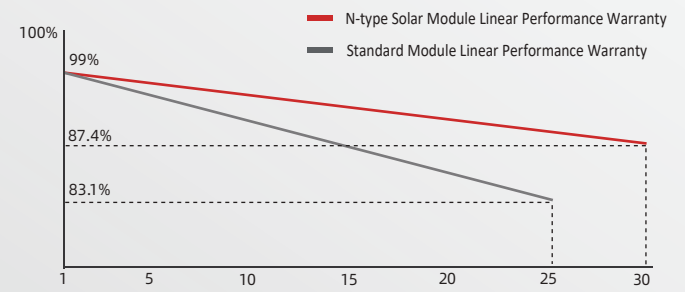

15 15-year product warranty

30 30-year linear power output warranty

HEADQUARTER: HORAY SOLAR CO., LTD. GLOBAL MARKETING AND SERVICE: HORAY SOLAR GMBH

sales@horaysolar.com www.horaysolar.com +86-510 83580688
No.300 Huiming Road, Huishan District, 214177 Wuxi, Jiangsu, P.R. China

info@horaysolar.com www.horaysolar.com
Robert-Bosch-Straße 27-29, 63225 Langen, Germany

MECHANICAL DIAGRAMS

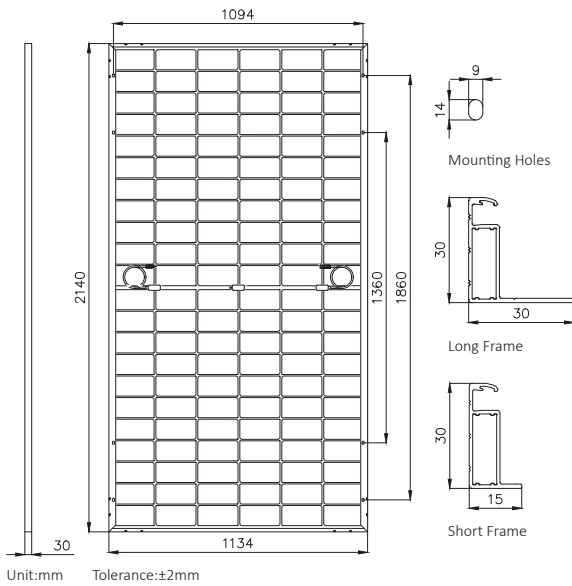

MECHANICAL PARAMETERS

Weight	29.5kg
Dimension	2140×1134×30mm
Cell Orientation	132 (6×22)
Junction Box	IP68, three diodes
Output Cable	4mm ² ,±300mm (length can be customized)
Connector	MC4 compatible
Glass	2.0+2.0mm AR coated heat strengthened glass
Frame	Anodized aluminum alloy frame
Packaging	37pcs per pallet/740pcs per 40'HC

CURVES OF PV MODULE

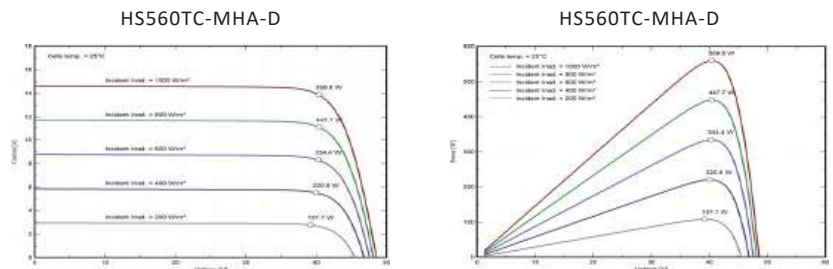

ELECTRICAL CHARACTERISTICS

Module Type	HS540TC-MHA-D		HS545TC-MHA-D		HS550TC-MHA-D		HS555TC-MHA-D		HS560TC-MHA-D	
	STC	NMOT	STC	NMOT	STC	NMOT	STC	NMOT	STC	NMOT
Maximum Power(Pmax/W)	540	411	545	415	550	419	555	423	560	427
Open Circuit Voltage(Voc/V)	47.68	47.68	47.88	47.88	48.07	48.07	48.27	48.27	48.51	48.51
Short Circuit Current(Isc/A)	14.34	10.92	14.41	10.98	14.48	11.04	14.56	11.09	14.61	11.14
Maximum Power Voltage(Vmp/V)	39.79	39.79	39.96	39.96	40.11	40.11	40.28	40.28	40.48	40.48
Maximum Power Current(Imp/A)	13.57	10.34	13.64	10.39	13.71	10.45	13.78	10.50	13.83	10.54
Module Efficiency(%)	22.3		22.5		22.7		22.9		23.1	

* Under Standard Test Conditions (STC) of irradiance of 1000 W/m², spectrum AM 1.5 and cell temperature of 25°C.

* Under Nominal Module Operating Temperature (NMOT), irradiance of 800 W/m², spectrum AM 1.5, ambient temperature 20°C, wind speed 1 m/s.

ELECTRICAL CHARACTERISTICS WITH 10% SOLAR IRRADIATION RATIO (BNPI)

Maximum Power(Pmax/W)	583	588	594	599	604
Open Circuit Voltage(Voc/V)	47.68	47.88	48.07	48.27	48.51
Short Circuit Current(Isc/A)	15.34	15.42	15.50	15.58	15.64
Maximum Power Voltage(Vmp/V)	39.79	39.96	40.11	40.28	40.48
Maximum Power Current(Imp/A)	14.65	14.72	14.80	14.87	14.93

*Rear side power gain:The additional gain from the rear side compared to the power of the front side at the standard test condition.It depends on mounting (structure,height,tilt angle etc.)and albedo of the ground.

OPERATING PARAMETERS

Operational Temperature	-40°C~+85°C
Power Output Tolerance	0~3%
Maximum System Voltage	1500V
Maximum Series Fuse Rating	25A
Nominal Operating Cell Temperature	45±2°C
Protection Class	Class II
Bifaciality	80±5%
Fire Rating	IEC Class A

*The actual test value may be slightly deviated from the technical parameters due to the difference in test methods.

MECHANICAL LOADING

Front Side Maximum Static Loading	5400Pa
Rear Side Maximum Static Loading	2400Pa
Hailstone Test	25mm Hailstone at the speed of 23m/s

TEMPERATURE RATINGS (STC)

Temperature Coefficient of Isc	+0.04%/°C
Temperature Coefficient of Voc	-0.23%/°C
Temperature Coefficient of Pmax	-0.28%/°C



610W

HORAY

TIER1
BloombergNEF

HS 186R-144 TC-D *Alpine* N-type Bifacial Modules

N-type
SMBB

SMBB Half-Cell Technology
More uniform current collection capability, reducing the current heat loss of the internal cells.

CONVERSION

Higher Output Power
The output power of 144 half-cells monocrystalline modules is up to 610W.

LOW LIGHT

Low Light Features
Higher performance under low light environment.

RESISTANT

Harsh Environmental Adaptability
Strict salt spray and ammonia corrosion test by the third party.

LID
LOW LID

N-type With Very Low LID
N-type solar cell has very low LID naturally which can reduce power degradation.

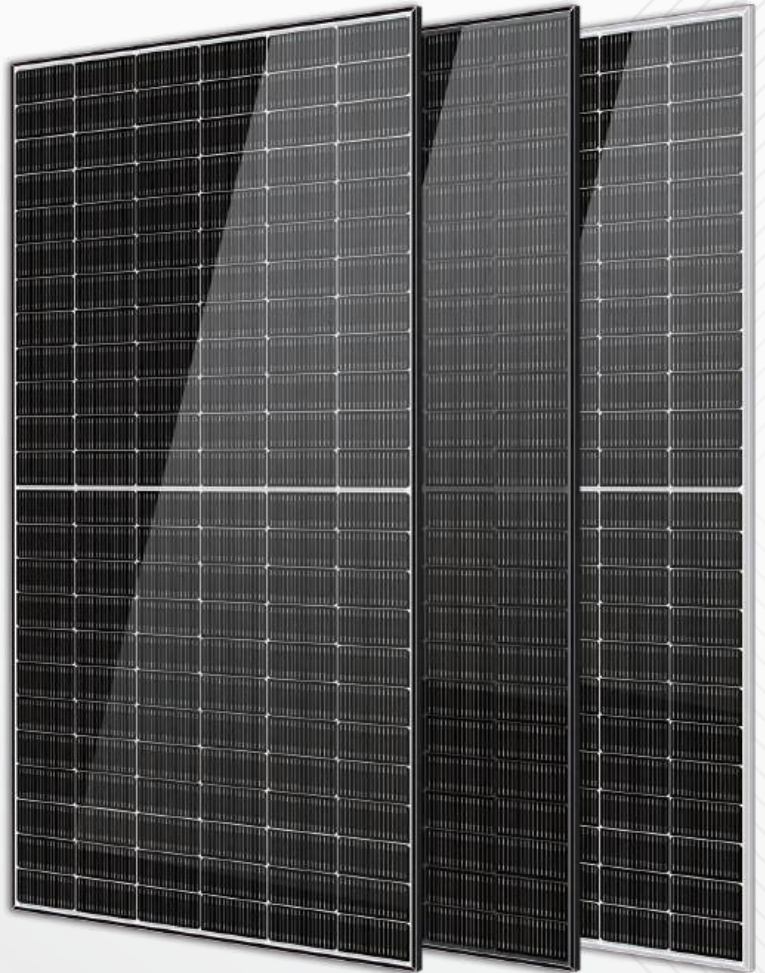

IEC61215:2021

IEC61730:2023

ISO9001:2015 Quality Management System

ISO14001:2015 Environmental Management System

IOS45001:2018 Occupational Health and Safety Management System

CE: Europe Standard

China Quality Certification Centre

Solar Product Certification

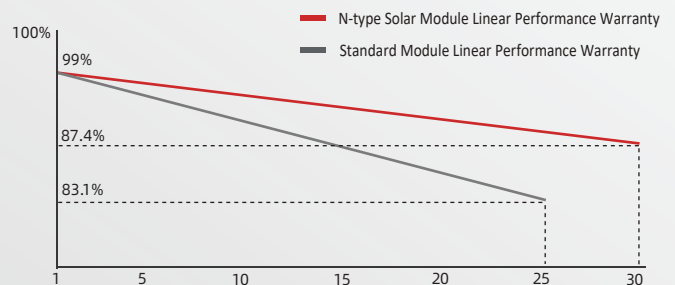
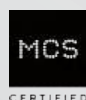

15-year product warranty



30-year linear power output warranty

HEADQUARTER: HORAY SOLAR CO., LTD.

GLOBAL MARKETING AND SERVICE: HORAY SOLAR GMBH

sales@horaysolar.com www.horaysolar.com +86-510 83580688
No.300 Huiming Road, Huishan District, 214177 Wuxi, Jiangsu, P.R. China

info@horaysolar.com www.horaysolar.com
Robert-Bosch-Straße 27-29, 63225 Langen, Germany

MECHANICAL DIAGRAMS

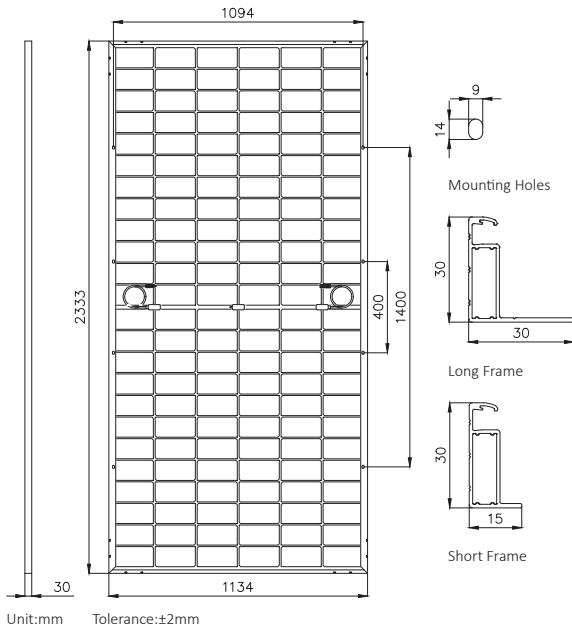

MECHANICAL PARAMETERS

Weight	32.5kg
Dimension	2333×1134×30mm
Cell Orientation	144 (6×24)
Junction Box	IP68, three diodes
Output Cable	4mm ² ,±300mm (length can be customized)
Connector	MC4 compatible
Glass	2.0+2.0mm AR coated heat strengthened glass
Frame	Anodized aluminum alloy frame
Packaging	36pcs per pallet/720pcs per 40'HC

CURVES OF PV MODULE

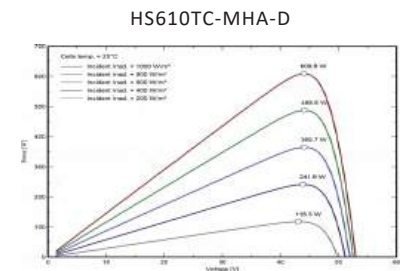
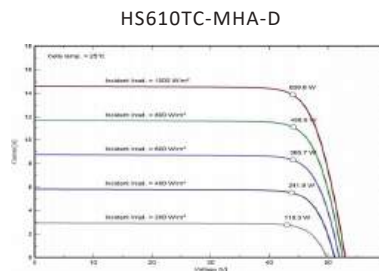

ELECTRICAL CHARACTERISTICS

Module Type	HS590TC-MHA-D		HS595TC-MHA-D		HS600TC-MHA-D		HS605TC-MHA-D		HS610TC-MHA-D	
	STC	NMOT	STC	NMOT	STC	NMOT	STC	NMOT	STC	NMOT
Maximum Power(Pmax/W)	590	450	595	453	600	457	605	461	610	465
Open Circuit Voltage(Voc/V)	52.02	52.02	52.24	52.24	52.44	52.44	52.65	52.65	52.92	52.92
Short Circuit Current(Isc/A)	14.36	10.94	14.42	10.99	14.48	11.04	14.55	11.08	14.59	11.12
Maximum Power Voltage(Vmp/V)	43.41	43.41	43.59	43.59	43.76	43.76	43.94	43.94	44.16	44.16
Maximum Power Current(Imp/A)	13.59	10.36	13.65	10.40	13.71	10.45	13.77	10.49	13.81	10.53
Module Efficiency(%)	22.3		22.5		22.7		22.9		23.1	

* Under Standard Test Conditions (STC) of irradiance of 1000 W/m², spectrum AM 1.5 and cell temperature of 25°C.

* Under Nominal Module Operating Temperature (NMOT), irradiance of 800 W/m², spectrum AM 1.5, ambient temperature 20°C, wind speed 1 m/s.

ELECTRICAL CHARACTERISTICS WITH 10% SOLAR IRRADIATION RATIO (BNPI)

Maximum Power(Pmax/W)	637	642	648	653	658
Open Circuit Voltage(Voc/V)	52.02	52.24	52.44	52.65	52.92
Short Circuit Current(Isc/A)	15.36	15.43	15.50	15.56	15.61
Maximum Power Voltage(Vmp/V)	43.41	43.59	43.76	43.94	44.16
Maximum Power Current(Imp/A)	14.67	14.73	14.80	14.86	14.91

*Rear side power gain:The additional gain from the rear side compared to the power of the front side at the standard test condition.It depends on mounting (structure,height,tilt angle etc.)and albedo of the ground.

OPERATING PARAMETERS

Operational Temperature	-40°C~+85°C
Power Output Tolerance	0~3%
Maximum System Voltage	1500V
Maximum Series Fuse Rating	25A
Nominal Operating Cell Temperature	45±2°C
Protection Class	Class II
Bifaciality	80±5%
Fire Rating	IEC Class A

*The actual test value may be slightly deviated from the technical parameters due to the difference in test methods.

MECHANICAL LOADING

Front Side Maximum Static Loading	5400Pa
Rear Side Maximum Static Loading	2400Pa
Hailstone Test	25mm Hailstone at the speed of 23m/s

TEMPERATURE RATINGS (STC)

Temperature Coefficient of Isc	+0.04%/°C
Temperature Coefficient of Voc	-0.23%/°C
Temperature Coefficient of Pmax	-0.28%/°C



475W

HORAY

TIER1
BloombergNEF

HS 191R-108 TC-D *Basin* N-type Bifacial Modules



SMBB Half-Cell Technology

More uniform current collection capability, reducing the current heat loss of the internal cells.



Higher Output Power

The output power of 108 half-cells monocrystalline modules is up to 475W.



Low Light Features

Higher performance under low light environment.



Harsh Environmental Adaptability

Strict salt spray and ammonia corrosion test by the third party.



N-type With Very Low LID

N-type solar cell has very low LID naturally which can reduce power degradation.

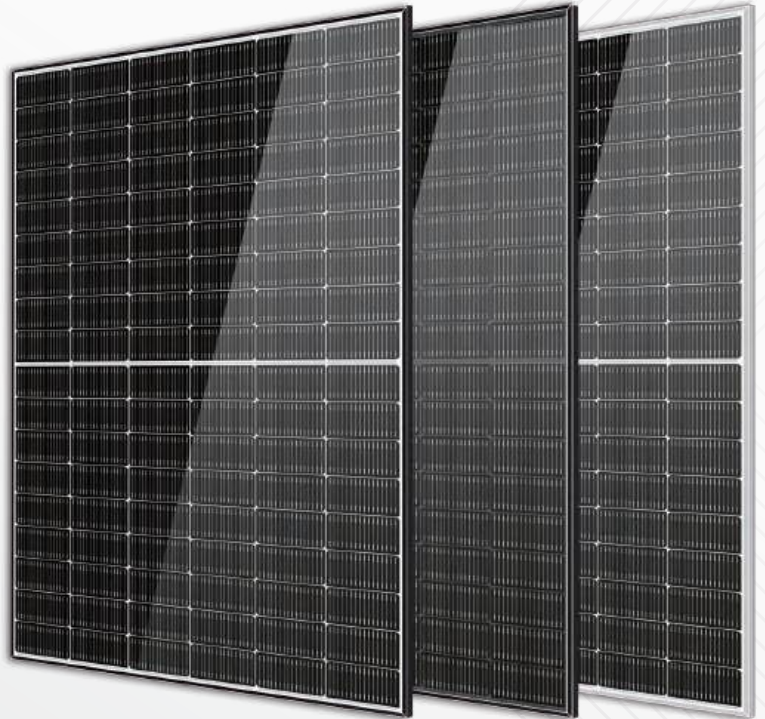

IEC61215:2021

IEC61730:2023

ISO9001:2015 Quality Management System

ISO14001:2015 Environmental Management System

IOS45001:2018 Occupational Health and Safety Management System

CE: Europe Standard

China Quality Certification Centre

Solar Product Certification

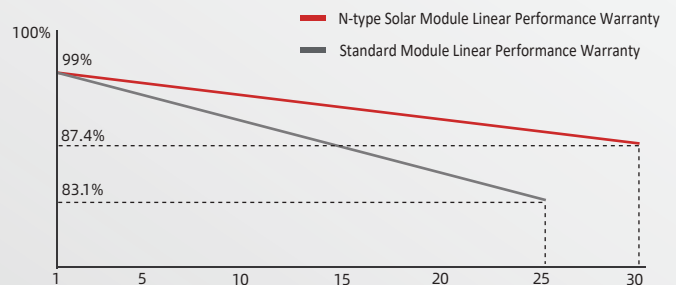

15-year product warranty



30-year linear power output warranty

HEADQUARTER: HORAY SOLAR CO., LTD.

GLOBAL MARKETING AND SERVICE: HORAY SOLAR GMBH

sales@horaysolar.com www.horaysolar.com +86-510 83580688
No.300 Huiming Road, Huishan District, 214177 Wuxi, Jiangsu, P.R. China

info@horaysolar.com www.horaysolar.com
Robert-Bosch-Straße 27-29, 63225 Langen, Germany

MECHANICAL DIAGRAMS

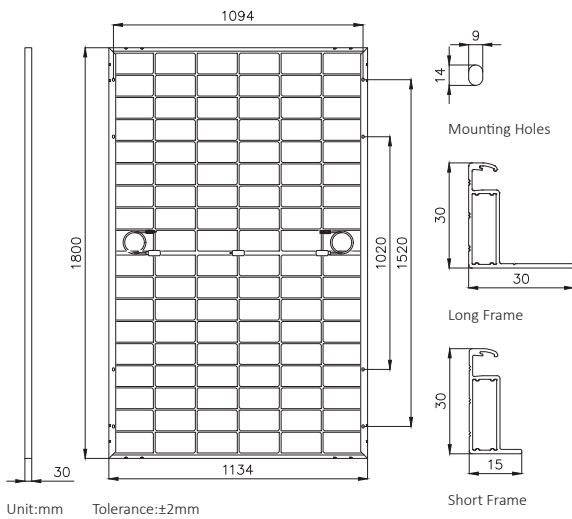

MECHANICAL PARAMETERS

Weight	25.0kg
Dimension	1800×1134×30mm
Cell Orientation	108 (6×18)
Junction Box	IP68, three diodes
Output Cable	4mm ² ,±300mm (length can be customized)
Connector	MC4 compatible
Glass	2.0+2.0mm AR coated heat strengthened glass
Frame	Anodized aluminum alloy frame
Packaging	37pcs per pallet/888pcs per 40'HC

CURVES OF PV MODULE

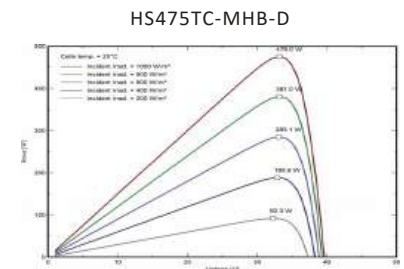
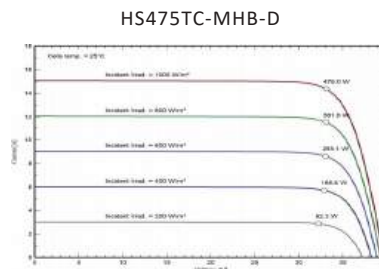

ELECTRICAL CHARACTERISTICS

Module Type	HS455TC-MHB-D		HS460TC-MHB-D		HS465TC-MHB-D		HS470TC-MHB-D		HS475TC-MHB-D	
	STC	NMOT	STC	NMOT	STC	NMOT	STC	NMOT	STC	NMOT
Maximum Power(Pmax/W)	455	381	460	386	465	390	470	394	475	398
Open Circuit Voltage(Voc/V)	38.90	38.90	39.08	39.08	39.26	39.26	39.31	39.31	39.61	39.61
Short Circuit Current(Isc/A)	14.68	11.19	14.78	11.26	14.87	11.33	15.01	11.44	15.06	11.47
Maximum Power Voltage(Vmp/V)	33.00	33.00	33.15	33.15	33.30	33.30	33.35	33.35	33.60	33.60
Maximum Power Current(Imp/A)	13.79	10.51	13.88	10.57	13.96	10.64	14.10	10.74	14.14	10.77
Module Efficiency(%)	22.3		22.6		22.8		23.0		22.3	

* Under Standard Test Conditions (STC) of irradiance of 1000 W/m², spectrum AM 1.5 and cell temperature of 25°C.

* Under Nominal Module Operating Temperature (NMOT), irradiance of 800 W/m², spectrum AM 1.5, ambient temperature 20°C, wind speed 1 m/s.

ELECTRICAL CHARACTERISTICS WITH 10% SOLAR IRRADIATION RATIO (BNPI)

Maximum Power(Pmax/W)	501	506	512	517	523
Open Circuit Voltage(Voc/V)	38.90	39.08	39.26	39.31	39.61
Short Circuit Current(Isc/A)	16.15	16.26	16.36	16.51	16.56
Maximum Power Voltage(Vmp/V)	33.00	33.15	33.30	33.35	33.60
Maximum Power Current(Imp/A)	15.17	15.26	15.36	15.50	15.55

*Rear side power gain:The additional gain from the rear side compared to the power of the front side at the standard test condition.It depends on mounting (structure,height,tilt angle etc.)and albedo of the ground.

OPERATING PARAMETERS

Operational Temperature	-40°C~+85°C
Power Output Tolerance	0~3%
Maximum System Voltage	1500V
Maximum Series Fuse Rating	30A
Nominal Operating Cell Temperature	45±2°C
Protection Class	Class II
Bifaciality	80±5%
Fire Rating	IEC Class A

*The actual test value may be slightly deviated from the technical parameters due to the difference in test methods.

MECHANICAL LOADING

Front Side Maximum Static Loading	5400Pa
Rear Side Maximum Static Loading	2400Pa
Hailstone Test	25mm Hailstone at the speed of 23m/s

TEMPERATURE RATINGS (STC)

Temperature Coefficient of Isc	+0.04%/°C
Temperature Coefficient of Voc	-0.23%/°C
Temperature Coefficient of Pmax	-0.28%/°C



520W

HORAY



HS 191R-120 TC-D Basin N-type Bifacial Modules



SMBB Half-Cell Technology

More uniform current collection capability, reducing the current heat loss of the internal cells.



Higher Output Power

The output power of 120 half-cells monocrystalline modules is up to 520W.



Low Light Features

Higher performance under low light environment.



Harsh Environmental Adaptability

Strict salt spray and ammonia corrosion test by the third party.



N-type With Very Low LID

N-type solar cell has very low LID naturally which can reduce power degradation.

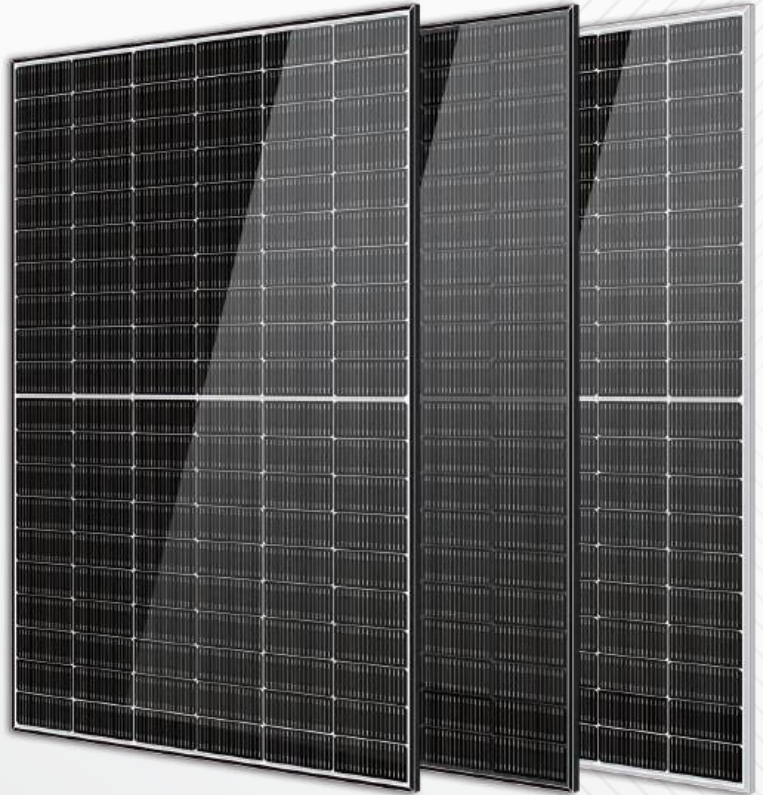

IEC61215:2021

IEC61730:2023

ISO9001:2015 Quality Management System

ISO14001:2015 Environmental Management System

IOS45001:2018 Occupational Health and Safety Management System

CE: Europe Standard

China Quality Certification Centre

Solar Product Certification

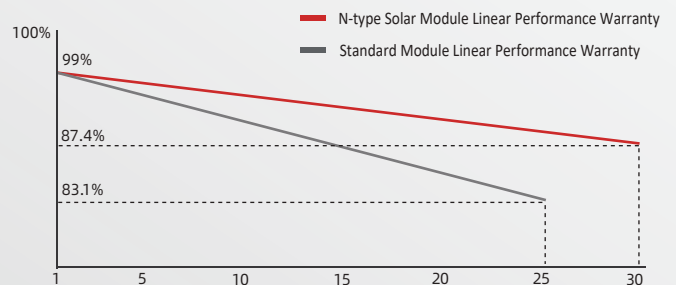
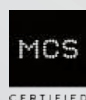

15-year product warranty



30-year linear power output warranty

HEADQUARTER: HORAY SOLAR CO., LTD.

GLOBAL MARKETING AND SERVICE: HORAY SOLAR GMBH

sales@horaysolar.com www.horaysolar.com +86-510 83580688

info@horaysolar.com www.horaysolar.com

No.300 Huiming Road, Huishan District, 214177 Wuxi, Jiangsu, P.R. China

Robert-Bosch-Straße 27-29, 63225 Langen, Germany

MECHANICAL DIAGRAMS

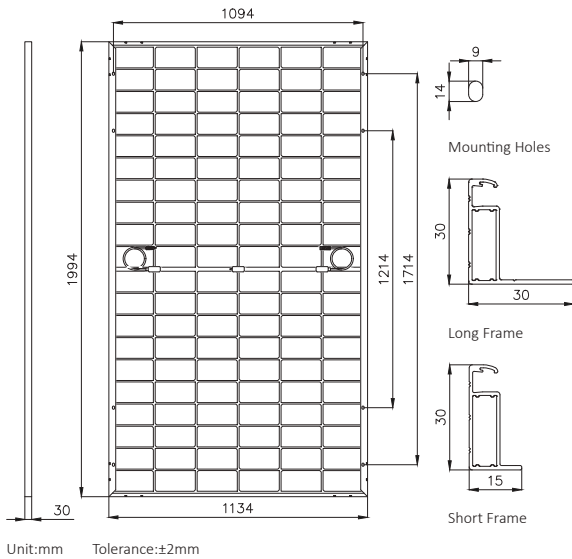

MECHANICAL PARAMETERS

Weight	28.0kg
Dimension	1994×1134×30mm
Cell Orientation	120 (6×20)
Junction Box	IP68, three diodes
Output Cable	4mm ² ,±300mm (length can be customized)
Connector	MC4 compatible
Glass	2.0+2.0mm AR coated heat strengthened glass
Frame	Anodized aluminum alloy frame
Packaging	37pcs per pallet/814pcs per 40'HC

CURVES OF PV MODULE

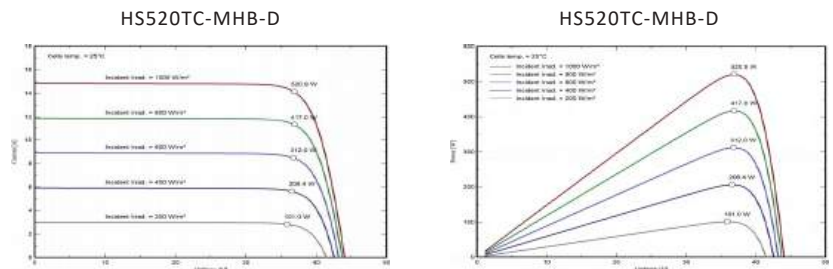

ELECTRICAL CHARACTERISTICS

Module Type	HS500TC-MHB-D		HS505TC-MHB-D		HS510TC-MHB-D		HS515TC-MHB-D		HS520TC-MHB-D	
	STC	NMOT	STC	NMOT	STC	NMOT	STC	NMOT	STC	NMOT
Maximum Power(Pmax/W)	500	419	505	423	510	427	515	432	520	436
Open Circuit Voltage(Voc/V)	43.23	43.23	43.42	43.42	43.62	43.62	43.68	43.68	44.01	44.01
Short Circuit Current(Isc/A)	14.52	11.07	14.60	11.13	14.68	11.19	14.80	11.28	14.83	11.30
Maximum Power Voltage(Vmp/V)	36.67	36.67	36.83	36.83	37.00	37.00	37.05	37.05	37.33	37.33
Maximum Power Current(Imp/A)	13.64	10.39	13.71	10.45	13.78	10.50	13.90	10.59	13.93	10.61
Module Efficiency(%)	22.1		22.3		22.6		22.8		23.0	

* Under Standard Test Conditions (STC) of irradiance of 1000 W/m², spectrum AM 1.5 and cell temperature of 25°C.

* Under Nominal Module Operating Temperature (NMOT), irradiance of 800 W/m², spectrum AM 1.5, ambient temperature 20°C, wind speed 1 m/s.

ELECTRICAL CHARACTERISTICS WITH 10% SOLAR IRRADIATION RATIO (BNPI)

Maximum Power(Pmax/W)	550	556	561	567	572
Open Circuit Voltage(Voc/V)	43.23	43.42	43.62	43.68	44.01
Short Circuit Current(Isc/A)	15.97	16.06	16.15	16.28	16.32
Maximum Power Voltage(Vmp/V)	36.67	36.83	37.00	37.05	37.33
Maximum Power Current(Imp/A)	15.00	15.08	15.16	15.29	15.32

*Rear side power gain:The additional gain from the rear side compared to the power of the front side at the standard test condition.It depends on mounting (structure,height,tilt angle etc.)and albedo of the ground.

OPERATING PARAMETERS

Operational Temperature	-40°C~+85°C
Power Output Tolerance	0~3%
Maximum System Voltage	1500V
Maximum Series Fuse Rating	30A
Nominal Operating Cell Temperature	45±2°C
Protection Class	Class II
Bifaciality	80±5%
Fire Rating	IEC Class A

*The actual test value may be slightly deviated from the technical parameters due to the difference in test methods.

MECHANICAL LOADING

Front Side Maximum Static Loading	5400Pa
Rear Side Maximum Static Loading	2400Pa
Hailstone Test	25mm Hailstone at the speed of 23m/s

TEMPERATURE RATINGS (STC)

Temperature Coefficient of Isc	+0.04%/°C
Temperature Coefficient of Voc	-0.23%/°C
Temperature Coefficient of Pmax	-0.28%/°C



570W

HORAY

TIER1
BloombergNEF

HS 191R-132 TC-D *Basin* N-type Bifacial Modules

N-type
SMBB

SMBB Half-Cell Technology
More uniform current collection capability, reducing the current heat loss of the internal cells.

CONVERSION

Higher Output Power
The output power of 132 half-cells monocrystalline modules is up to 570W.

LOW LIGHT

Low Light Features
Higher performance under low light environment.

RESISTANT

Harsh Environmental Adaptability
Strict salt spray and ammonia corrosion test by the third party.

LID
LOW LID

N-type With Very Low LID
N-type solar cell has very low LID naturally which can reduce power degradation.

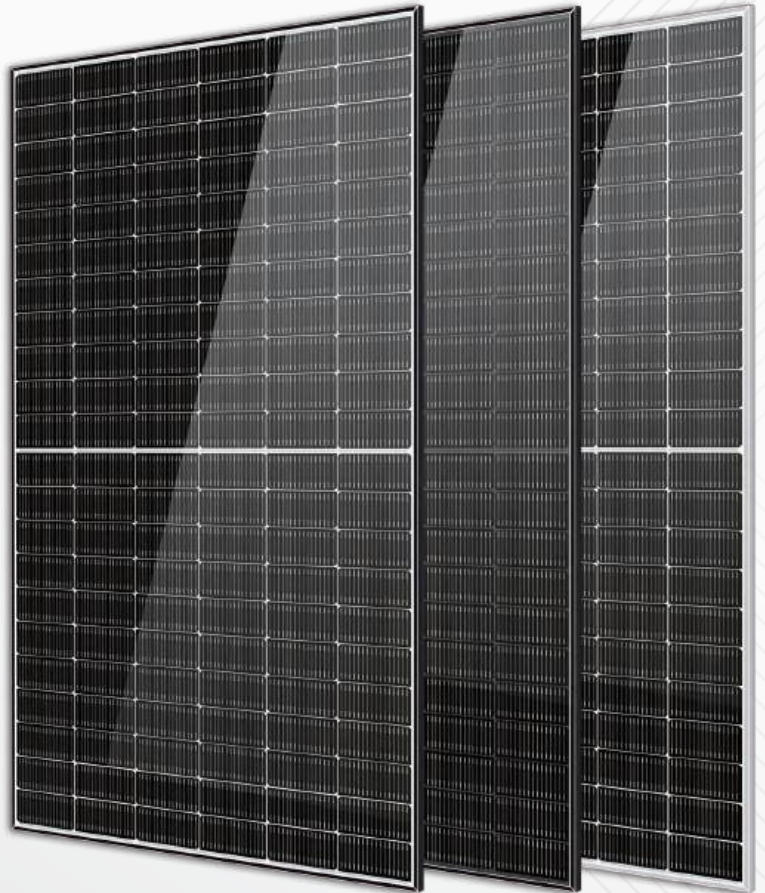

IEC61215:2021

IEC61730:2023

ISO9001:2015 Quality Management System

ISO14001:2015 Environmental Management System

IOS45001:2018 Occupational Health and Safety Management System

CE: Europe Standard

China Quality Certification Centre

Solar Product Certification

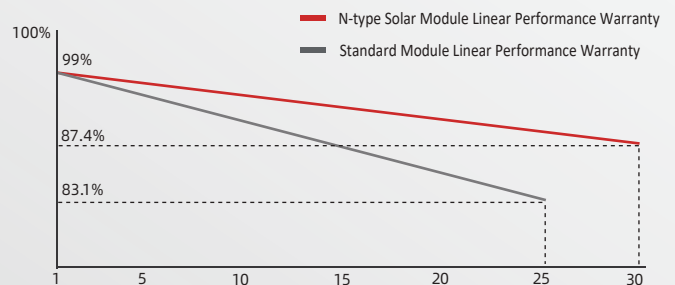
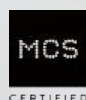

15

15-year product warranty

30

30-year linear power output warranty

HEADQUARTER: HORAY SOLAR CO., LTD.

GLOBAL MARKETING AND SERVICE: HORAY SOLAR GMBH

sales@horaysolar.com www.horaysolar.com +86-510 83580688

info@horaysolar.com www.horaysolar.com

No.300 Huiming Road, Huishan District, 214177 Wuxi, Jiangsu, P.R. China

Robert-Bosch-Straße 27-29, 63225 Langen, Germany

MECHANICAL DIAGRAMS

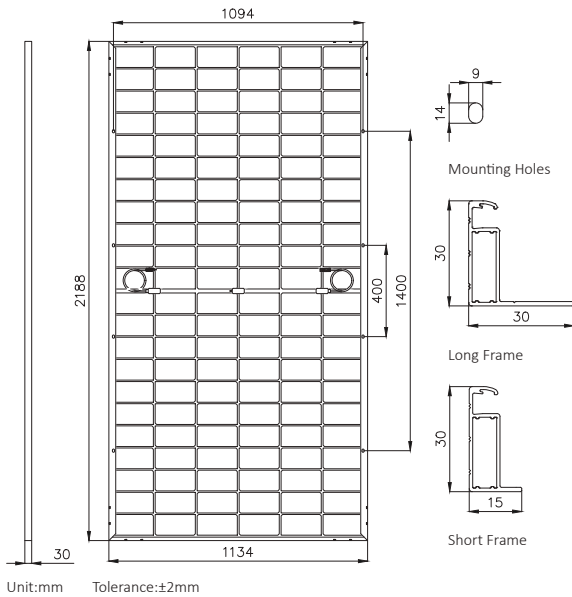

MECHANICAL PARAMETERS

Weight	30.5kg
Dimension	2188×1134×30mm
Cell Orientation	132 (6×22)
Junction Box	IP68, three diodes
Output Cable	4mm ² ,±300mm (length can be customized)
Connector	MC4 compatible
Glass	2.0+2.0mm AR coated heat strengthened glass
Frame	Anodized aluminum alloy frame
Packaging	37pcs per pallet/740pcs per 40'HC

CURVES OF PV MODULE

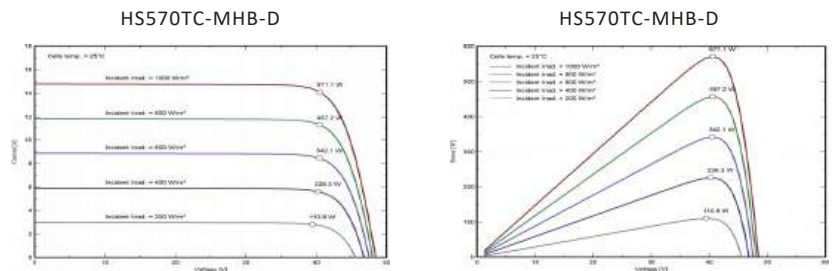

ELECTRICAL CHARACTERISTICS

Module Type	HS550TC-MHB-D		HS555TC-MHB-D		HS560TC-MHB-D		HS565TC-MHB-D		HS570TC-MHB-D	
	STC	NMOT	STC	NMOT	STC	NMOT	STC	NMOT	STC	NMOT
Maximum Power(Pmax/W)	550	461	555	465	560	469	565	474	570	478
Open Circuit Voltage(Voc/V)	47.55	47.55	47.76	47.76	47.98	47.98	48.05	48.05	48.41	48.41
Short Circuit Current(Isc/A)	14.52	11.07	14.59	11.12	14.65	11.17	14.76	11.25	14.78	11.26
Maximum Power Voltage(Vmp/V)	40.33	40.33	40.52	40.52	40.70	40.70	40.76	40.76	41.07	41.07
Maximum Power Current(Imp/A)	13.64	10.39	13.70	10.44	13.76	10.48	13.86	10.56	13.88	10.58
Module Efficiency(%)	22.2		22.4		22.6		22.8		23.0	

* Under Standard Test Conditions (STC) of irradiance of 1000 W/m², spectrum AM 1.5 and cell temperature of 25°C.

* Under Nominal Module Operating Temperature (NMOT), irradiance of 800 W/m², spectrum AM 1.5, ambient temperature 20°C, wind speed 1 m/s.

ELECTRICAL CHARACTERISTICS WITH 10% SOLAR IRRADIATION RATIO (BNPI)

Maximum Power(Pmax/W)	605	611	616	622	627
Open Circuit Voltage(Voc/V)	47.55	47.76	47.98	48.05	48.41
Short Circuit Current(Isc/A)	15.97	16.05	16.12	16.24	16.26
Maximum Power Voltage(Vmp/V)	40.33	40.52	40.70	40.76	41.07
Maximum Power Current(Imp/A)	15.00	15.07	15.14	15.25	15.27

*Rear side power gain:The additional gain from the rear side compared to the power of the front side at the standard test condition.It depends on mounting (structure,height,tilt angle etc.)and albedo of the ground.

OPERATING PARAMETERS

Operational Temperature	-40°C~+85°C
Power Output Tolerance	0~3%
Maximum System Voltage	1500V
Maximum Series Fuse Rating	30A
Nominal Operating Cell Temperature	45±2°C
Protection Class	Class II
Bifaciality	80±5%
Fire Rating	IEC Class A

*The actual test value may be slightly deviated from the technical parameters due to the difference in test methods.

MECHANICAL LOADING

Front Side Maximum Static Loading	5400Pa
Rear Side Maximum Static Loading	2400Pa
Hailstone Test	25mm Hailstone at the speed of 23m/s

TEMPERATURE RATINGS (STC)

Temperature Coefficient of Isc	+0.04%/°C
Temperature Coefficient of Voc	-0.23%/°C
Temperature Coefficient of Pmax	-0.28%/°C



620W

HORAY

TIER1
BloombergNEF

HS 191R-144 TC-D *Basin* N-type Bifacial Modules

N-type
SMBB

SMBB Half-Cell Technology
More uniform current collection capability, reducing the current heat loss of the internal cells.

CONVERSION

Higher Output Power
The output power of 144 half-cells monocrystalline modules is up to 620W.

LOW LIGHT

Low Light Features
Higher performance under low light environment.

RESISTANT

Harsh Environmental Adaptability
Strict salt spray and ammonia corrosion test by the third party.

LID
LOW LID

N-type With Very Low LID
N-type solar cell has very low LID naturally which can reduce power degradation.

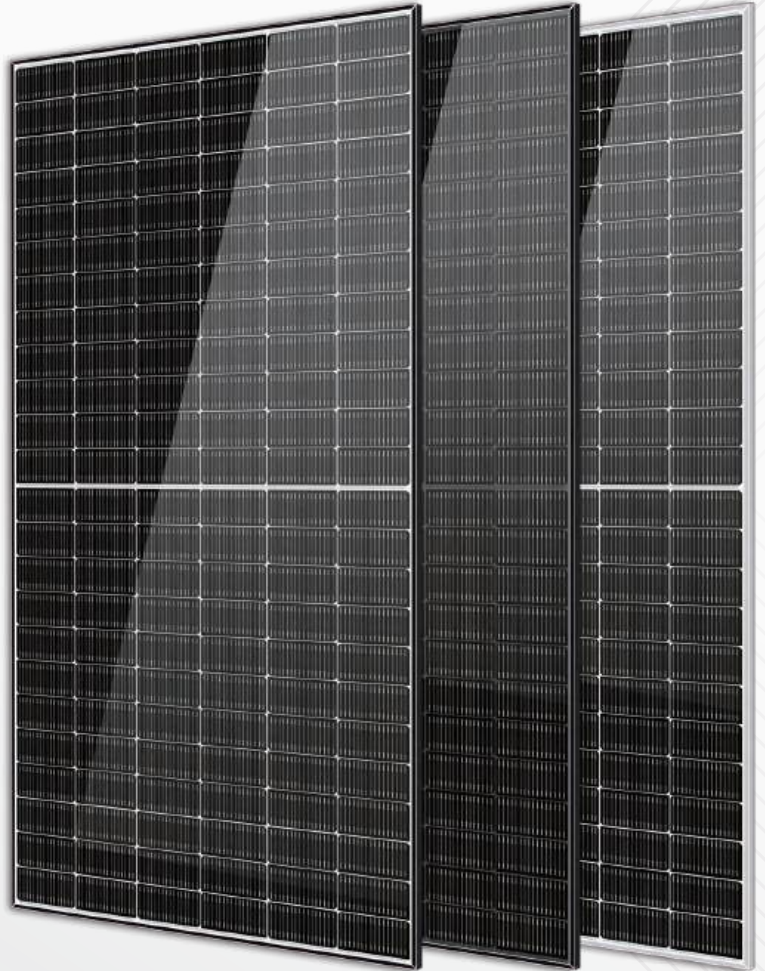

IEC61215:2021

IEC61730:2023

ISO9001:2015 Quality Management System

ISO14001:2015 Environmental Management System

IOS45001:2018 Occupational Health and Safety Management System

CE: Europe Standard

China Quality Certification Centre

Solar Product Certification

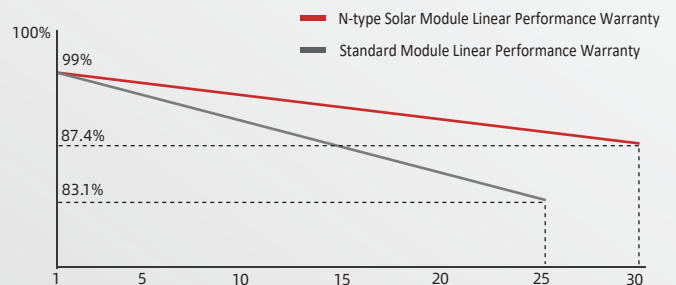

15-year product warranty



30-year linear power output warranty

HEADQUARTER: HORAY SOLAR CO., LTD.

GLOBAL MARKETING AND SERVICE: HORAY SOLAR GMBH

sales@horaysolar.com www.horaysolar.com +86-510 83580688
No.300 Huiming Road, Huishan District, 214177 Wuxi, Jiangsu, P.R. China

info@horaysolar.com www.horaysolar.com
Robert-Bosch-Straße 27-29, 63225 Langen, Germany

MECHANICAL DIAGRAMS

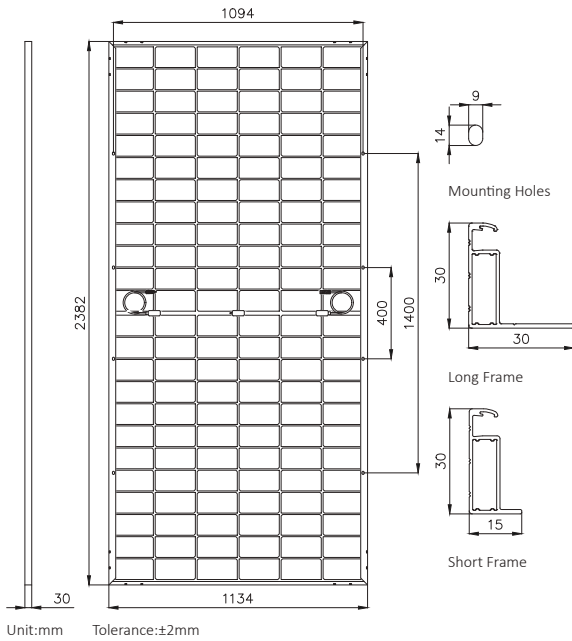

MECHANICAL PARAMETERS

Weight	33.7kg
Dimension	2382×1134×30mm
Cell Orientation	144 (6×24)
Junction Box	IP68, three diodes
Output Cable	4mm ² ,±300mm (length can be customized)
Connector	MC4 compatible
Glass	2.0+2.0mm AR coated heat strengthened glass
Frame	Anodized aluminum alloy frame
Packaging	36pcs per pallet/720pcs per 40'HC

CURVES OF PV MODULE

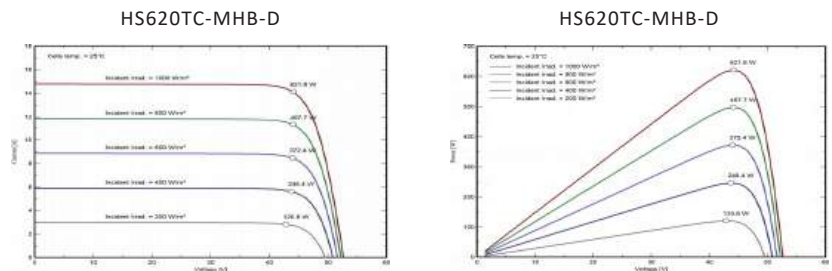

ELECTRICAL CHARACTERISTICS

Module Type	HS600TC-MHB-D		HS605TC-MHB-D		HS610TC-MHB-D		HS615TC-MHB-D		HS620TC-MHB-D	
	STC	NMOT	STC	NMOT	STC	NMOT	STC	NMOT	STC	NMOT
Maximum Power(Pmax/W)	600	503	605	507	610	511	615	515	620	520
Open Circuit Voltage(Voc/V)	51.80	51.80	52.00	52.00	52.20	52.20	52.40	52.40	52.60	52.60
Short Circuit Current(Isc/A)	14.54	11.08	14.60	11.13	14.66	11.17	14.72	11.22	14.78	11.26
Maximum Power Voltage(Vmp/V)	44.00	44.00	44.20	44.20	44.40	44.40	44.60	44.60	44.80	44.80
Maximum Power Current(Imp/A)	13.64	10.39	13.69	10.43	13.74	10.47	13.79	10.51	13.84	10.55
Module Efficiency(%)	22.2		22.4		22.6		22.8		23.0	

* Under Standard Test Conditions (STC) of irradiance of 1000 W/m², spectrum AM 1.5 and cell temperature of 25°C.

* Under Nominal Module Operating Temperature (NMOT), irradiance of 800 W/m², spectrum AM 1.5, ambient temperature 20°C, wind speed 1 m/s.

ELECTRICAL CHARACTERISTICS WITH 10% SOLAR IRRADIATION RATIO (BNPI)

Maximum Power(Pmax/W)	660	666	671	677	682
Open Circuit Voltage(Voc/V)	51.80	52.00	52.20	52.40	52.60
Short Circuit Current(Isc/A)	15.99	16.06	16.13	16.19	16.26
Maximum Power Voltage(Vmp/V)	44.00	44.20	44.40	44.60	44.80
Maximum Power Current(Imp/A)	15.00	15.06	15.11	15.17	15.22

*Rear side power gain:The additional gain from the rear side compared to the power of the front side at the standard test condition.It depends on mounting (structure,height,tilt angle etc.)and albedo of the ground.

OPERATING PARAMETERS

Operational Temperature	-40°C~+85°C
Power Output Tolerance	0~3%
Maximum System Voltage	1500V
Maximum Series Fuse Rating	30A
Nominal Operating Cell Temperature	45±2°C
Protection Class	Class II
Bifaciality	80±5%
Fire Rating	IEC Class A

*The actual test value may be slightly deviated from the technical parameters due to the difference in test methods.

MECHANICAL LOADING

Front Side Maximum Static Loading	5400Pa
Rear Side Maximum Static Loading	2400Pa
Hailstone Test	25mm Hailstone at the speed of 23m/s

TEMPERATURE RATINGS (STC)

Temperature Coefficient of Isc	+0.04%/°C
Temperature Coefficient of Voc	-0.23%/°C
Temperature Coefficient of Pmax	-0.28%/°C



445~465 Watt

HORAY



HS 210R-96 TC-D Cosmos N-type Bifacial Modules



SMBB Half-Cell Technology

More uniform current collection capability, reducing the current heat loss of the internal cells.



Higher Output Power

The output power of 96 half-cells monocrystalline modules is up to 465W.



Low Light Features

Higher performance under low light environment.



Harsh Environmental Adaptability

Strict salt spray and ammonia corrosion test by the third party.



N-type With Very Low LID

N-type solar cell has very low LID naturally which can reduce power degradation.

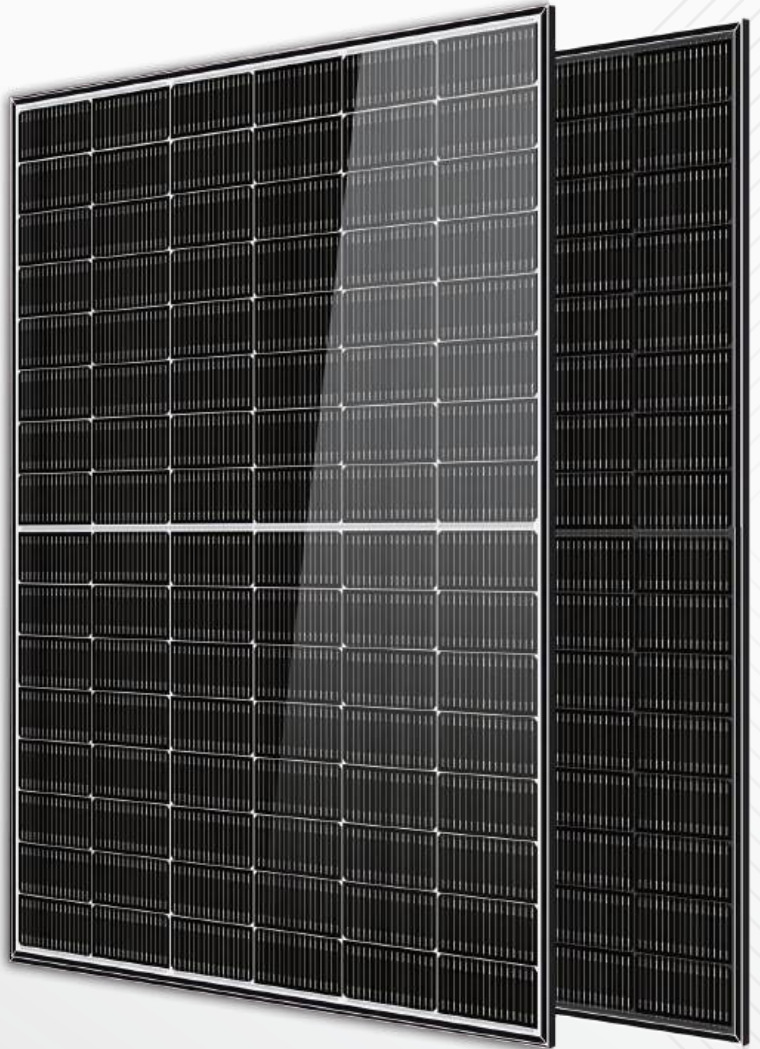

IEC61215:2021

IEC61730:2023

ISO9001:2015 Quality Management System

ISO14001:2015 Environmental Management System

ISO45001:2018 Occupational Health and Safety Management System

CE: Europe Standard

China Quality Certification Centre

Solar Product Certification

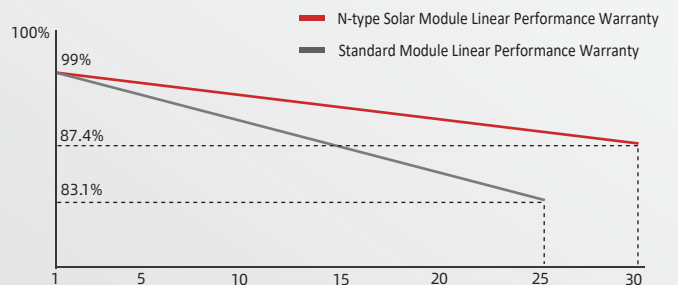

15-year product warranty



30-year linear power output warranty

HEADQUARTER: HORAY SOLAR CO., LTD.

GLOBAL MARKETING AND SERVICE: HORAY SOLAR GMBH

sales@horaysolar.com www.horaysolar.com +86-510 83580688
No.300 Huiming Road, Huishan District, 214177 Wuxi, Jiangsu, P.R. China

info@horaysolar.com www.horaysolar.com
Robert-Bosch-Straße 27-29, 63225 Langen, Germany

MECHANICAL DIAGRAMS

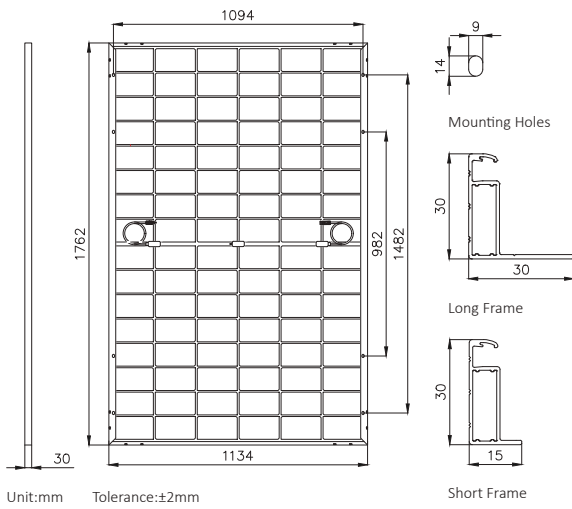

MECHANICAL PARAMETERS

Weight	24.5kg
Dimension	1762×1134×30mm
Cell Orientation	96 (6×16)
Junction Box	IP68, three diodes
Output Cable	4mm ² ,±1100mm (length can be customized)
Connector	MC4 compatible
Glass	2.0+2.0mm AR coated heat strengthened glass
Frame	Anodized aluminum alloy frame
Packaging	37pcs per pallet/962pcs per 40'HC

CURVES OF PV MODULE

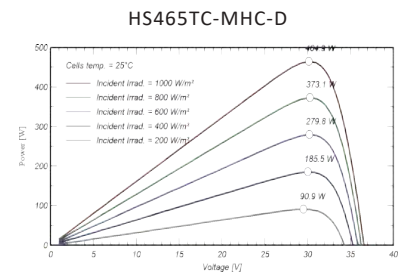
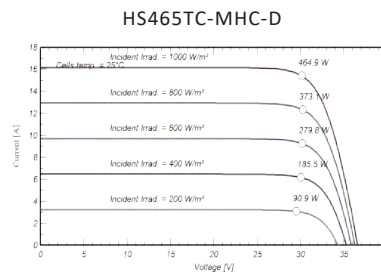

ELECTRICAL CHARACTERISTICS

Module Type	HS445TC-MHC-D		HS450TC-MHC-D		HS455TC-MHC-D		HS460TC-MHC-D		HS465TC-MHC-D	
	STC	NMOT	STC	NMOT	STC	NMOT	STC	NMOT	STC	NMOT
Maximum Power(Pmax/W)	445	347	450	351	455	355	460	359	465	363
Open Circuit Voltage(Voc/V)	35.87	35.62	36.04	35.79	36.21	35.96	36.39	36.13	36.56	36.30
Short Circuit Current(Isc/A)	15.77	12.30	15.87	12.38	15.97	12.45	16.07	12.53	16.16	12.61
Maximum Power Voltage(Vmp/V)	29.81	30.14	29.95	30.28	30.10	30.43	30.24	30.57	30.38	30.72
Maximum Power Current(Imp/A)	14.93	11.52	15.02	11.59	15.12	11.66	15.21	11.74	15.30	11.81
Module Efficiency(%)	22.3		22.5		22.8		23.0		23.3	

* Under Standard Test Conditions (STC) of irradiance of 1000 W/m², spectrum AM 1.5 and cell temperature of 25°C.

* Under Nominal Module Operating Temperature (NMOT), irradiance of 800 W/m², spectrum AM 1.5, ambient temperature 20°C, wind speed 1 m/s.

ELECTRICAL CHARACTERISTICS WITH 10% SOLAR IRRADIATION RATIO (BNPI)

Maximum Power(Pmax/W)	490	495	501	506	512
Open Circuit Voltage(Voc/V)	35.87	36.04	36.21	36.39	36.56
Short Circuit Current(Isc/A)	17.50	17.61	17.72	17.83	17.94
Maximum Power Voltage(Vmp/V)	29.81	29.95	30.10	30.24	30.38
Maximum Power Current(Imp/A)	16.42	16.53	16.63	16.73	16.83

*Rear side power gain:The additional gain from the rear side compared to the power of the front side at the standard test condition.It depends on mounting (structure,height,tilt angle etc.)and albedo of the ground.

OPERATING PARAMETERS

Operational Temperature	-40°C~+85°C
Power Output Tolerance	0~3%
Maximum System Voltage	1500V
Maximum Series Fuse Rating	30A
Nominal Operating Cell Temperature	45±2°C
Protection Class	Class II
Bifaciality	80±5%
Fire Rating	IEC Class A

*The actual test value may be slightly deviated from the technical parameters due to the difference in test methods.

MECHANICAL LOADING

Front Side Maximum Static Loading	5400Pa
Rear Side Maximum Static Loading	2400Pa
Hailstone Test	25mm Hailstone at the speed of 23m/s

TEMPERATURE RATINGS (STC)

Temperature Coefficient of Isc	+0.04%/°C
Temperature Coefficient of Voc	-0.23%/°C
Temperature Coefficient of Pmax	-0.28%/°C



500~520 Watt

HORAY



HS 210R-108 TC-D Cosmos N-type Bifacial Modules



SMBB Half-Cell Technology

More uniform current collection capability, reducing the current heat loss of the internal cells.



Higher Output Power

The output power of 108 half-cells monocrystalline modules is up to 520W.



Low Light Features

Higher performance under low light environment.



Harsh Environmental Adaptability

Strict salt spray and ammonia corrosion test by the third party.



N-type With Very Low LID

N-type solar cell has very low LID naturally which can reduce power degradation.

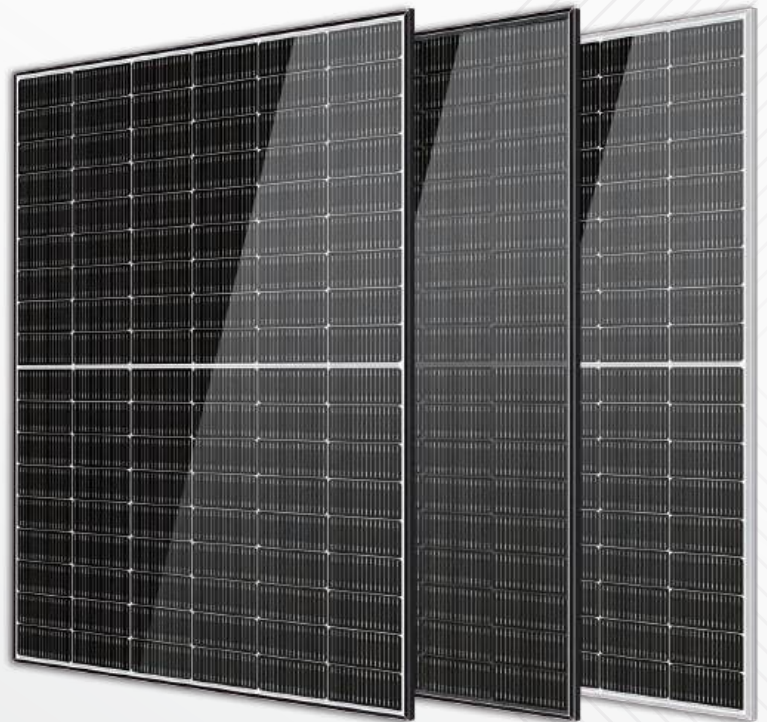

IEC61215:2021

IEC61730:2023

ISO9001:2015 Quality Management System

ISO14001:2015 Environmental Management System

ISO45001:2018 Occupational Health and Safety Management System

CE: Europe Standard

China Quality Certification Centre

Solar Product Certification

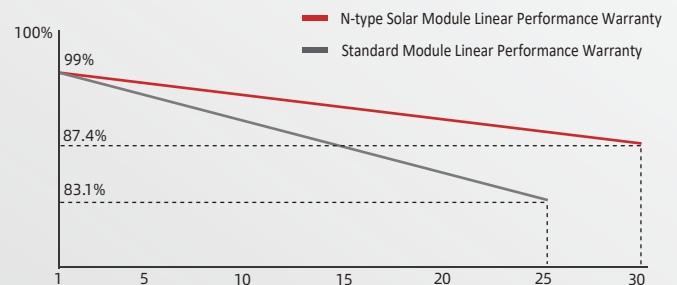
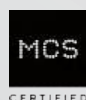

15-year product warranty



30-year linear power output warranty

HEADQUARTER: HORAY SOLAR CO., LTD.

GLOBAL MARKETING AND SERVICE: HORAY SOLAR GMBH

sales@horaysolar.com www.horaysolar.com +86-510 83580688
No.300 Huiming Road, Huishan District, 214177 Wuxi, Jiangsu, P.R. China

info@horaysolar.com www.horaysolar.com
Robert-Bosch-Straße 27-29, 63225 Langen, Germany

MECHANICAL DIAGRAMS

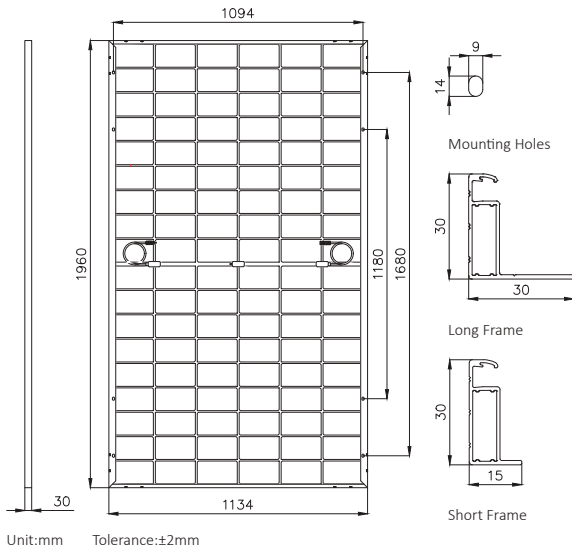

MECHANICAL PARAMETERS

Weight	27.0kg
Dimension	1960×1134×30mm
Cell Orientation	108(6×18)
Junction Box	IP68, three diodes
Output Cable	4mm ² ,±1100mm (length can be customized)
Connector	MC4 compatible
Glass	2.0+2.0mm AR coated heat strengthened glass
Frame	Anodized aluminum alloy frame
Packaging	37pcs per pallet/888pcs per 40'HC

CURVES OF PV MODULE

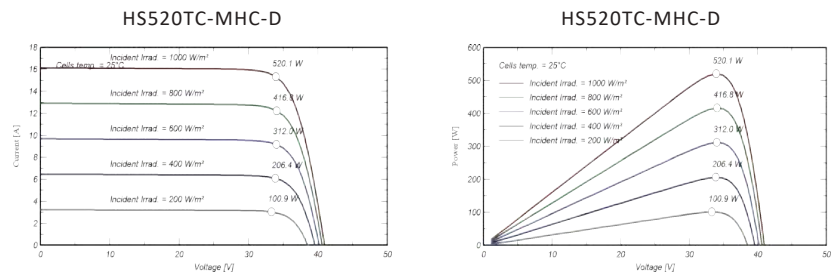

ELECTRICAL CHARACTERISTICS

Module Type	HS500TC-MHC-D		HS505TC-MHC-D		HS510TC-MHC-D		HS515TC-MHC-D		HS520TC-MHC-D	
	STC	NMOT	STC	NMOT	STC	NMOT	STC	NMOT	STC	NMOT
Maximum Power(Pmax/W)	500	390	505	394	510	398	515	402	520	406
Open Circuit Voltage(Voc/V)	40.16	39.87	40.35	40.07	40.55	40.26	40.74	40.46	40.94	40.65
Short Circuit Current(Isc/A)	15.82	12.34	15.90	12.41	15.98	12.47	16.06	12.53	16.14	12.59
Maximum Power Voltage(Vmp/V)	33.37	33.74	33.53	33.90	33.70	34.07	33.86	34.23	34.02	34.39
Maximum Power Current(Imp/A)	14.98	11.56	15.06	11.62	15.14	11.68	15.21	11.74	15.29	11.79
Module Efficiency(%)	22.4		22.7		22.9		23.1		23.3	

* Under Standard Test Conditions (STC) of irradiance of 1000 W/m², spectrum AM 1.5 and cell temperature of 25°C.

* Under Nominal Module Operating Temperature (NMOT), irradiance of 800 W/m², spectrum AM 1.5, ambient temperature 20°C, wind speed 1 m/s.

ELECTRICAL CHARACTERISTICS WITH 10% SOLAR IRRADIATION RATIO (BNPI)

Maximum Power(Pmax/W)	550	556	561	567	572
Open Circuit Voltage(Voc/V)	40.16	40.35	40.55	40.74	40.94
Short Circuit Current(Isc/A)	17.56	17.65	17.74	17.83	17.92
Maximum Power Voltage(Vmp/V)	33.37	33.53	33.70	33.86	34.02
Maximum Power Current(Imp/A)	16.48	16.57	16.65	16.73	16.81

*Rear side power gain:The additional gain from the rear side compared to the power of the front side at the standard test condition.It depends on mounting (structure,height,tilt angle etc.)and albedo of the ground.

OPERATING PARAMETERS

Operational Temperature	-40°C~+85°C
Power Output Tolerance	0~3%
Maximum System Voltage	1500V
Maximum Series Fuse Rating	30A
Nominal Operating Cell Temperature	45±2°C
Protection Class	Class II
Bifaciality	80±5%
Fire Rating	IEC Class A

*The actual test value may be slightly deviated from the technical parameters due to the difference in test methods.

MECHANICAL LOADING

Front Side Maximum Static Loading	5400Pa
Rear Side Maximum Static Loading	2400Pa
Hailstone Test	25mm Hailstone at the speed of 23m/s

TEMPERATURE RATINGS (STC)

Temperature Coefficient of Isc	+0.04%/°C
Temperature Coefficient of Voc	-0.23%/°C
Temperature Coefficient of Pmax	-0.28%/°C



515W

HORAY

TIER1
BloombergNEF

HS 210R-108 TC-D Cosmos N-type Bifacial Modules

N-type SMBB **SMBB Half-Cell Technology**
More uniform current collection capability, reducing the current heat loss of the internal cells.

CONVERSION **Higher Output Power**
The output power of 108 half-cells monocrystalline modules is up to 515W.

LOW LIGHT **Low Light Features**
Higher performance under low light environment.

RESISTANT **Harsh Environmental Adaptability**
Strict salt spray and ammonia corrosion test by the third party.

LOW LID **N-type With Very Low LID**
N-type solar cell has very low LID naturally which can reduce power degradation.

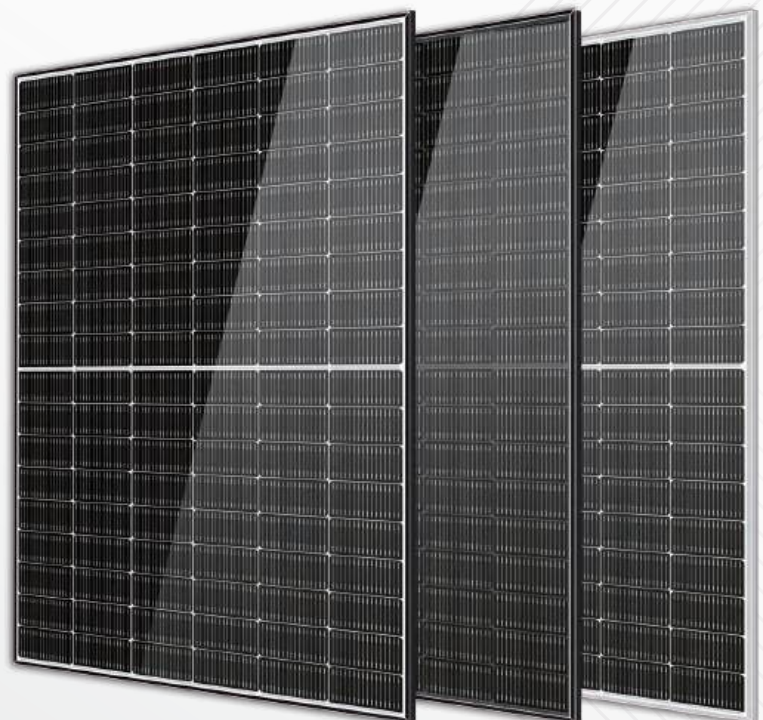

- IEC61215:2021
- IEC61730:2023
- ISO9001:2015 Quality Management System
- ISO14001:2015 Environmental Management System
- ISO45001:2018 Occupational Health and Safety Management System
- CE: Europe Standard
- China Quality Certification Centre
- Solar Product Certification

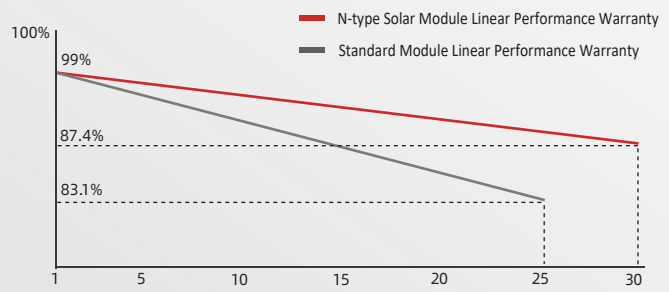

15 15-year product warranty

30 30-year linear power output warranty

HEADQUARTER: HORAY SOLAR CO., LTD. GLOBAL MARKETING AND SERVICE: HORAY SOLAR GMBH

sales@horaysolar.com www.horaysolar.com +86-510 83580688
No.300 Huiming Road, Huishan District, 214177 Wuxi, Jiangsu, P.R. China

info@horaysolar.com www.horaysolar.com
Robert-Bosch-Straße 27-29, 63225 Langen, Germany

MECHANICAL DIAGRAMS

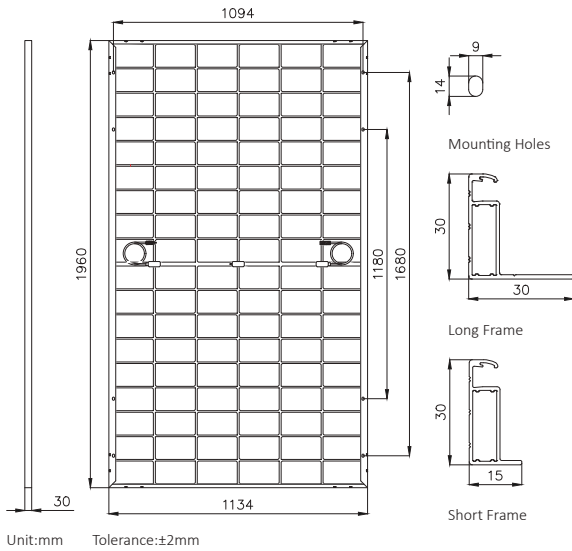

MECHANICAL PARAMETERS

Weight	27.0kg
Dimension	1960×1134×30mm
Cell Orientation	108(6×18)
Junction Box	IP68, three diodes
Output Cable	4mm ² ,±1100mm (length can be customized)
Connector	MC4 compatible
Glass	2.0+2.0mm AR coated heat strengthened glass
Frame	Anodized aluminum alloy frame
Packaging	37pcs per pallet/888pcs per 40'HC

CURVES OF PV MODULE

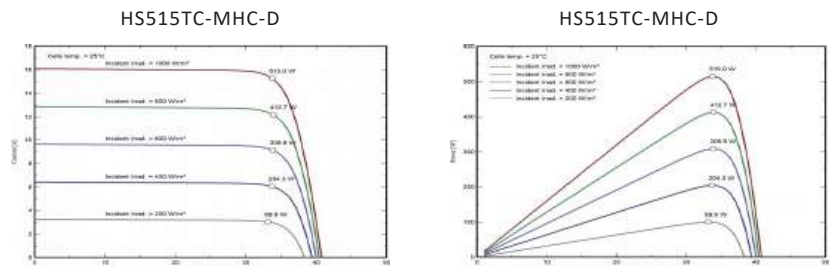

ELECTRICAL CHARACTERISTICS

Module Type	HS495TC-MHC-D		HS500TC-MHC-D		HS505TC-MHC-D		HS510TC-MHC-D		HS515TC-MHC-D	
	STC	NMOT	STC	NMOT	STC	NMOT	STC	NMOT	STC	NMOT
Maximum Power(Pmax/W)	495	377	500	381	505	385	510	389	515	392
Open Circuit Voltage(Voc/V)	39.96	37.96	40.16	38.14	40.35	38.51	40.55	38.51	40.74	38.70
Short Circuit Current(Isc/A)	15.74	12.71	15.82	12.78	15.90	12.84	15.98	12.91	16.06	12.97
Maximum Power Voltage(Vmp/V)	33.21	30.93	33.37	31.08	33.53	31.23	33.70	31.38	33.86	31.53
Maximum Power Current(Imp/A)	14.91	12.20	14.98	12.26	15.06	12.32	15.14	12.38	15.21	12.45
Module Efficiency(%)	22.2		22.4		22.7		22.9		23.1	

* Under Standard Test Conditions (STC) of irradiance of 1000 W/m², spectrum AM 1.5 and cell temperature of 25°C.

* Under Nominal Module Operating Temperature (NMOT), irradiance of 800 W/m², spectrum AM 1.5, ambient temperature 20°C, wind speed 1 m/s.

ELECTRICAL CHARACTERISTICS WITH 10% SOLAR IRRADIATION RATIO (BNPI)

Maximum Power(Pmax/W)	545	550	556	561	567
Open Circuit Voltage(Voc/V)	39.96	40.16	40.35	40.55	40.74
Short Circuit Current(Isc/A)	17.47	17.56	17.65	17.74	17.83
Maximum Power Voltage(Vmp/V)	33.21	33.37	33.53	33.70	33.86
Maximum Power Current(Imp/A)	16.40	16.48	16.57	16.65	16.73

*Rear side power gain:The additional gain from the rear side compared to the power of the front side at the standard test condition.It depends on mounting (structure,height,tilt angle etc.)and albedo of the ground.

OPERATING PARAMETERS

Operational Temperature	-40°C~+85°C
Power Output Tolerance	0~3%
Maximum System Voltage	1500V
Maximum Series Fuse Rating	30A
Nominal Operating Cell Temperature	45±2°C
Protection Class	Class II
Bifaciality	80±5%
Fire Rating	IEC Class A

*The actual test value may be slightly deviated from the technical parameters due to the difference in test methods.

MECHANICAL LOADING

Front Side Maximum Static Loading	5400Pa
Rear Side Maximum Static Loading	2400Pa
Hailstone Test	25mm Hailstone at the speed of 23m/s

TEMPERATURE RATINGS (STC)

Temperature Coefficient of Isc	+0.04%/°C
Temperature Coefficient of Voc	-0.23%/°C
Temperature Coefficient of Pmax	-0.28%/°C



560~580 Watt

HORAY

TIER1
BloombergNEF

HS 210R-120 TC-D Cosmos N-type Bifacial Modules



SMBB Half-Cell Technology

More uniform current collection capability, reducing the current heat loss of the internal cells.



Higher Output Power

The output power of 120 half-cells monocrystalline modules is up to 580W.



Low Light Features

Higher performance under low light environment.



Harsh Environmental Adaptability

Strict salt spray and ammonia corrosion test by the third party.



N-type With Very Low LID

N-type solar cell has very low LID naturally which can reduce power degradation.

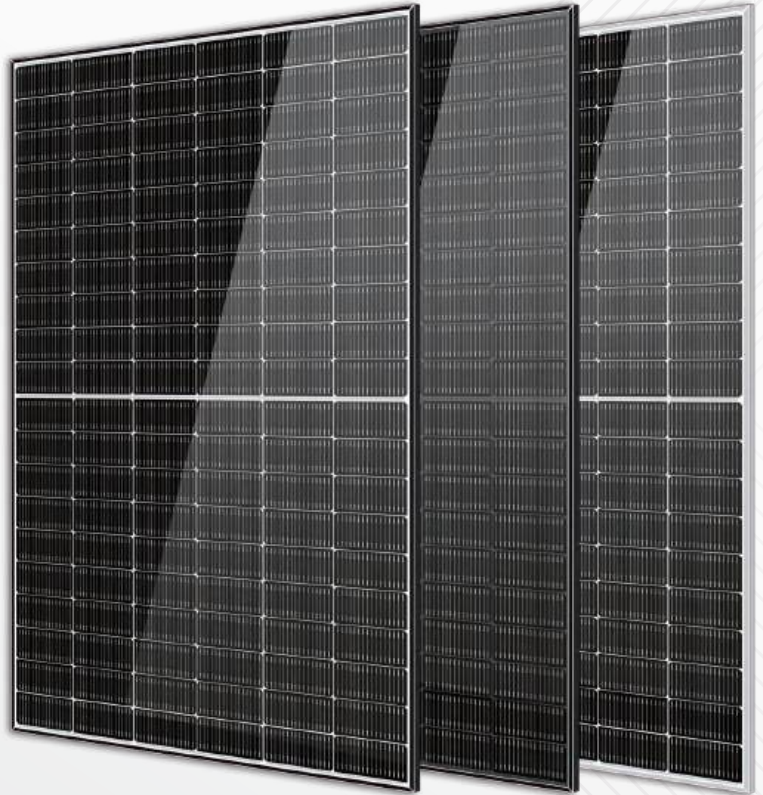

IEC61215:2021

IEC61730:2023

ISO9001:2015 Quality Management System

ISO14001:2015 Environmental Management System

ISO45001:2018 Occupational Health and Safety Management System

CE: Europe Standard

China Quality Certification Centre

Solar Product Certification

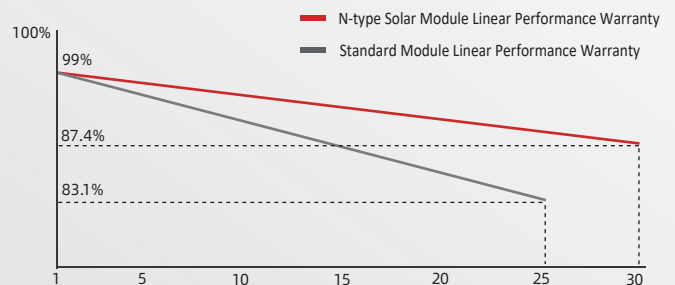

15-year product warranty



30-year linear power output warranty

HEADQUARTER: HORAY SOLAR CO., LTD.

GLOBAL MARKETING AND SERVICE: HORAY SOLAR GMBH

sales@horaysolar.com www.horaysolar.com +86-510 83580688
No.300 Huiming Road, Huishan District, 214177 Wuxi, Jiangsu, P.R. China

info@horaysolar.com www.horaysolar.com
Robert-Bosch-Straße 27-29, 63225 Langen, Germany

MECHANICAL DIAGRAMS

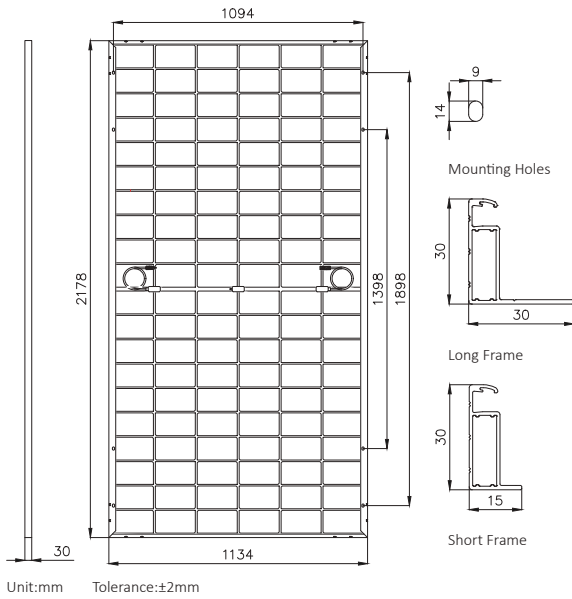

MECHANICAL PARAMETERS

Weight	30.5kg
Dimension	2178×1134×30mm
Cell Orientation	120(6×20)
Junction Box	IP68, three diodes
Output Cable	4mm ² ,±300mm(length can be customized)
Connector	MC4 compatible
Glass	2.0+2.0mm AR coated heat strengthened glass
Frame	Anodized aluminum alloy frame
Packaging	37pcs per pallet/740pcs per 40'HC

CURVES OF PV MODULE

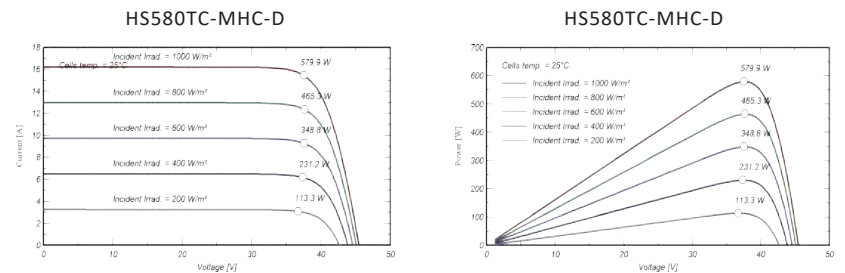

ELECTRICAL CHARACTERISTICS

Module Type	HS560TC-MHC-D		HS565TC-MHC-D		HS570TC-MHC-D		HS575TC-MHC-D		HS580TC-MHC-D	
	STC	NMOT	STC	NMOT	STC	NMOT	STC	NMOT	STC	NMOT
Maximum Power(Pmax/W)	560	437	565	441	570	445	575	449	580	452
Open Circuit Voltage(Voc/V)	44.62	44.30	44.83	44.52	45.05	44.74	45.27	44.95	45.48	45.17
Short Circuit Current(Isc/A)	15.95	12.44	16.01	12.49	16.08	12.54	16.14	12.59	16.20	12.64
Maximum Power Voltage(Vmp/V)	37.08	37.49	37.26	37.67	37.44	37.85	37.62	38.03	37.80	38.22
Maximum Power Current(Imp/A)	15.10	11.65	15.16	11.70	15.22	11.75	15.28	11.79	15.34	11.84
Module Efficiency(%)	22.7		22.9		23.1		23.3		23.5	

* Under Standard Test Conditions (STC) of irradiance of 1000 W/m², spectrum AM 1.5 and cell temperature of 25°C.

* Under Nominal Module Operating Temperature (NMOT), irradiance of 800 W/m², spectrum AM 1.5, ambient temperature 20°C, wind speed 1 m/s.

ELECTRICAL CHARACTERISTICS WITH 10% SOLAR IRRADIATION RATIO (BNPI)

Maximum Power(Pmax/W)	616	622	627	633	638
Open Circuit Voltage(Voc/V)	44.62	44.83	45.05	45.27	45.48
Short Circuit Current(Isc/A)	17.54	17.62	17.69	17.75	17.82
Maximum Power Voltage(Vmp/V)	37.08	37.26	37.44	37.62	37.80
Maximum Power Current(Imp/A)	16.61	16.68	16.75	16.81	16.88

*Rear side power gain:The additional gain from the rear side compared to the power of the front side at the standard test condition.It depends on mounting (structure,height,tilt angle etc.)and albedo of the ground.

OPERATING PARAMETERS

Operational Temperature	-40°C~+85°C
Power Output Tolerance	0~3%
Maximum System Voltage	1500V
Maximum Series Fuse Rating	30A
Nominal Operating Cell Temperature	45±2°C
Protection Class	Class II
Bifaciality	80±5%
Fire Rating	IEC Class A

*The actual test value may be slightly deviated from the technical parameters due to the difference in test methods.

MECHANICAL LOADING

Front Side Maximum Static Loading	5400Pa
Rear Side Maximum Static Loading	2400Pa
Hailstone Test	25mm Hailstone at the speed of 23m/s

TEMPERATURE RATINGS (STC)

Temperature Coefficient of Isc	+0.04%/°C
Temperature Coefficient of Voc	-0.23%/°C
Temperature Coefficient of Pmax	-0.28%/°C



620~640 Watt

HORAY

TIER1
BloombergNEF

HS **210R-132** TC-D *Cosmos* N-type Bifacial Modules



SMBB Half-Cell Technology

More uniform current collection capability, reducing the current heat loss of the internal cells.



Higher Output Power

The output power of 132 half-cells monocrystalline modules is up to 640W.



Low Light Features

Higher performance under low light environment.



Harsh Environmental Adaptability

Strict salt spray and ammonia corrosion test by the third party.



N-type With Very Low LID

N-type solar cell has very low LID naturally which can reduce power degradation.

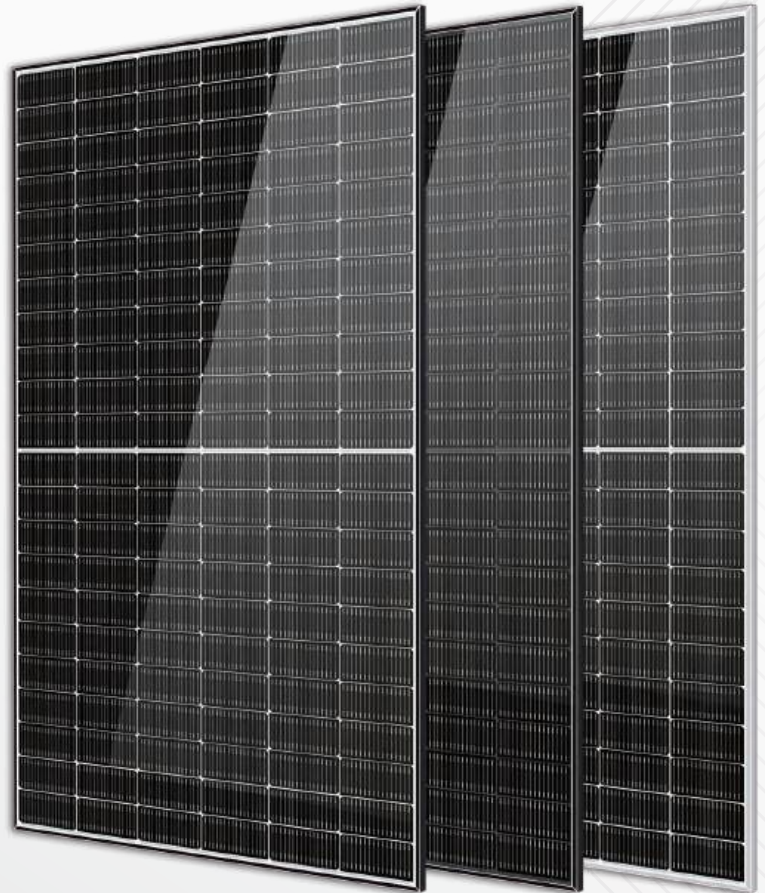

IEC61215:2021

IEC61730:2023

ISO9001:2015 Quality Management System

ISO14001:2015 Environmental Management System

ISO45001:2018 Occupational Health and Safety Management System

CE: Europe Standard

China Quality Certification Centre

Solar Product Certification

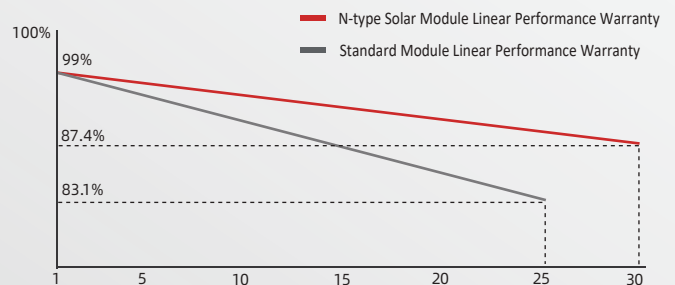

15-year product warranty



30-year linear power output warranty

HEADQUARTER: HORAY SOLAR CO., LTD.

GLOBAL MARKETING AND SERVICE: HORAY SOLAR GMBH

sales@horaysolar.com www.horaysolar.com +86-510 83580688

info@horaysolar.com www.horaysolar.com

No.300 Huiming Road, Huishan District, 214177 Wuxi, Jiangsu, P.R. China

Robert-Bosch-Straße 27-29, 63225 Langen, Germany

MECHANICAL DIAGRAMS

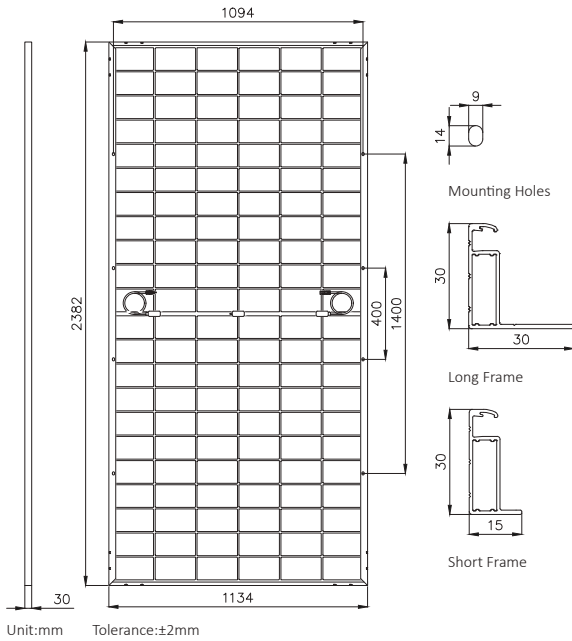

MECHANICAL PARAMETERS

Weight	33.7kg
Dimension	2382×1134×30mm
Cell Orientation	132(6×22)
Junction Box	IP68, three diodes
Output Cable	4mm ² ,±300mm(length can be customized)
Connector	MC4 compatible
Glass	2.0+2.0mm AR coated heat strengthened glass
Frame	Anodized aluminum alloy frame
Packaging	36pcs per pallet/720pcs per 40'HC

CURVES OF PV MODULE

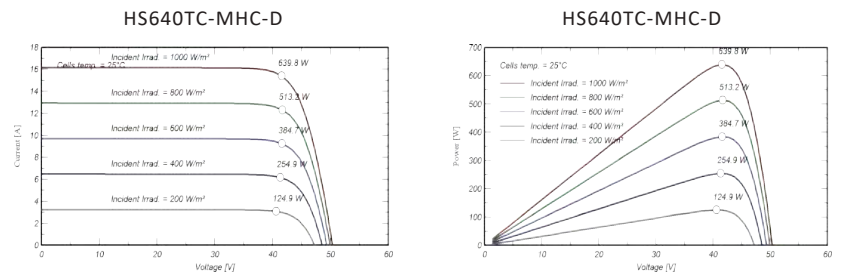

ELECTRICAL CHARACTERISTICS

Module Type	HS620TC-MHC-D		HS625TC-MHC-D		HS630TC-MHC-D		HS635TC-MHC-D		HS640TC-MHC-D	
	STC	NMOT	STC	NMOT	STC	NMOT	STC	NMOT	STC	NMOT
Maximum Power(Pmax/W)	620	484	625	488	630	491	635	495	640	499
Open Circuit Voltage(Voc/V)	49.40	49.05	49.63	49.29	49.87	49.52	50.11	49.76	50.35	50.00
Short Circuit Current(Isc/A)	15.95	12.44	16.00	12.48	16.05	12.52	16.10	12.56	16.15	12.60
Maximum Power Voltage(Vmp/V)	41.05	41.50	41.25	41.70	41.45	41.90	41.65	42.10	41.84	42.30
Maximum Power Current(Imp/A)	15.10	11.65	15.15	11.69	15.20	11.73	15.25	11.76	15.29	11.80
Module Efficiency(%)	22.9		23.1		23.3		23.5		23.7	

* Under Standard Test Conditions (STC) of irradiance of 1000 W/m², spectrum AM 1.5 and cell temperature of 25°C.

* Under Nominal Module Operating Temperature (NMOT), irradiance of 800 W/m², spectrum AM 1.5, ambient temperature 20°C, wind speed 1 m/s.

ELECTRICAL CHARACTERISTICS WITH 10% SOLAR IRRADIATION RATIO (BNPI)

Maximum Power(Pmax/W)	682	688	693	699	704
Open Circuit Voltage(Voc/V)	49.40	49.63	49.87	50.11	50.35
Short Circuit Current(Isc/A)	17.55	17.60	17.66	17.71	17.77
Maximum Power Voltage(Vmp/V)	41.05	41.25	41.45	41.65	41.84
Maximum Power Current(Imp/A)	16.61	16.67	16.72	16.77	16.82

*Rear side power gain:The additional gain from the rear side compared to the power of the front side at the standard test condition.It depends on mounting (structure,height,tilt angle etc.)and albedo of the ground.

OPERATING PARAMETERS

Operational Temperature	-40°C~+85°C
Power Output Tolerance	0~3%
Maximum System Voltage	1500V
Maximum Series Fuse Rating	30A
Nominal Operating Cell Temperature	45±2°C
Protection Class	Class II
Bifaciality	80±5%
Fire Rating	IEC Class A

*The actual test value may be slightly deviated from the technical parameters due to the difference in test methods.

MECHANICAL LOADING

Front Side Maximum Static Loading	5400Pa
Rear Side Maximum Static Loading	2400Pa
Hailstone Test	25mm Hailstone at the speed of 23m/s

TEMPERATURE RATINGS (STC)

Temperature Coefficient of Isc	+0.04%/°C
Temperature Coefficient of Voc	-0.23%/°C
Temperature Coefficient of Pmax	-0.28%/°C



630W

HORAY

TIER1
BloombergNEF

HS **210R-132** TC-D *Cosmos* N-type Bifacial Modules

N-type
SMBB
SMBB Half-Cell Technology
More uniform current collection capability, reducing the current heat loss of the internal cells.

CONVERSION
Higher Output Power
The output power of 132 half-cells monocrystalline modules is up to 630W.

LOW LIGHT
Low Light Features
Higher performance under low light environment.

RESISTANT
Harsh Environmental Adaptability
Strict salt spray and ammonia corrosion test by the third party.

LID
LOW LID
N-type With Very Low LID
N-type solar cell has very low LID naturally which can reduce power degradation.

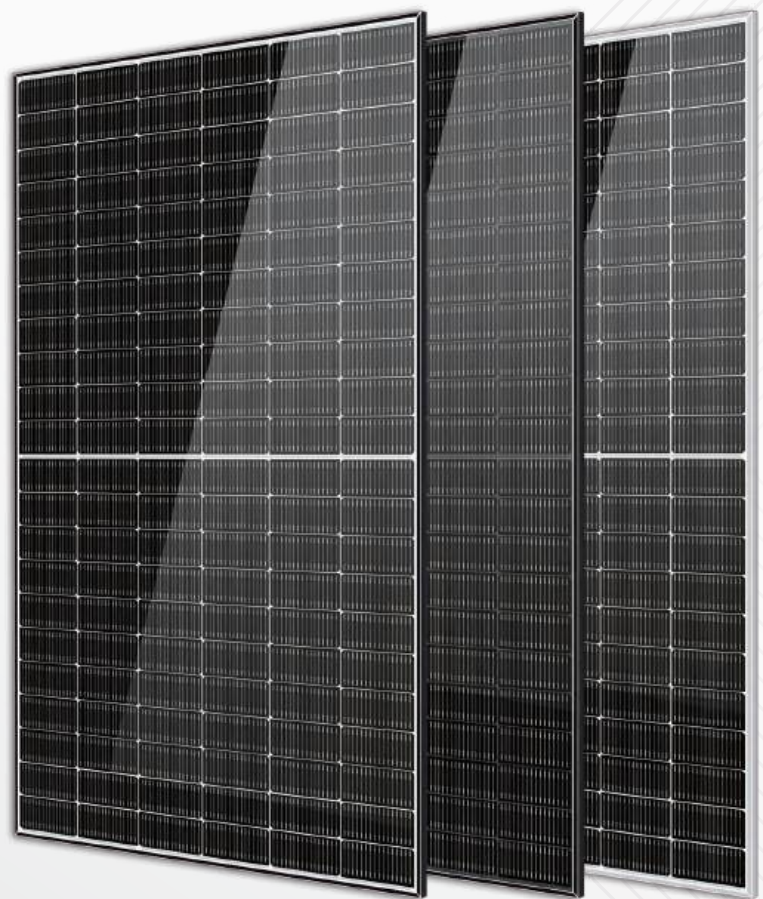

- IEC61215:2021
- IEC61730:2023
- ISO9001:2015 Quality Management System
- ISO14001:2015 Environmental Management System
- ISO45001:2018 Occupational Health and Safety Management System
- CE: Europe Standard
- China Quality Certification Centre
- Solar Product Certification

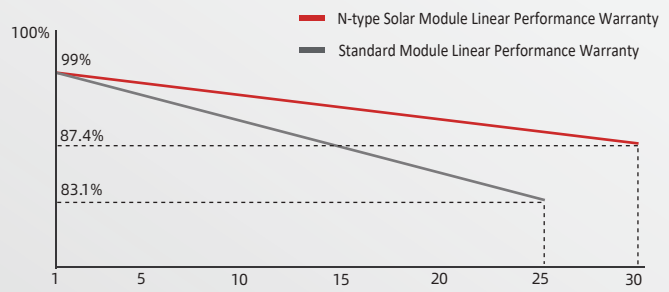

15 15-year product warranty

30 30-year linear power output warranty

HEADQUARTER: HORAY SOLAR CO., LTD. GLOBAL MARKETING AND SERVICE: HORAY SOLAR GMBH

sales@horaysolar.com www.horaysolar.com +86-510 83580688
No.300 Huiming Road, Huishan District, 214177 Wuxi, Jiangsu, P.R. China

info@horaysolar.com www.horaysolar.com
Robert-Bosch-Straße 27-29, 63225 Langen, Germany

MECHANICAL DIAGRAMS

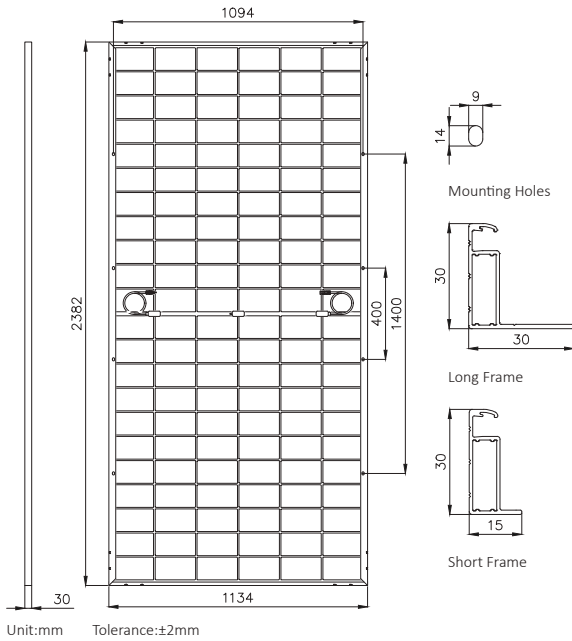

MECHANICAL PARAMETERS

Weight	33.7kg
Dimension	2382×1134×30mm
Cell Orientation	132(6×22)
Junction Box	IP68, three diodes
Output Cable	4mm ² ,±300mm(length can be customized)
Connector	MC4 compatible
Glass	2.0+2.0mm AR coated heat strengthened glass
Frame	Anodized aluminum alloy frame
Packaging	36pcs per pallet/720pcs per 40'HC

CURVES OF PV MODULE

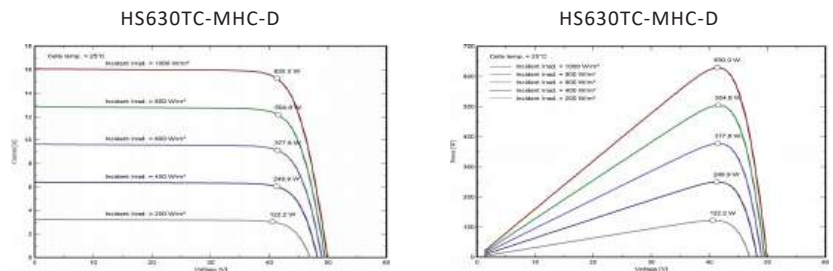

ELECTRICAL CHARACTERISTICS

Module Type	HS610TC-MHC-D		HS615TC-MHC-D		HS620TC-MHC-D		HS625TC-MHC-D		HS630TC-MHC-D	
	STC	NMOT	STC	NMOT	STC	NMOT	STC	NMOT	STC	NMOT
Maximum Power(Pmax/W)	610	465	615	469	620	472	625	476	630	480
Open Circuit Voltage(Voc/V)	48.92	46.47	49.16	46.70	49.40	46.92	49.63	47.15	49.87	47.38
Short Circuit Current(Isc/A)	15.85	12.80	15.90	12.84	15.95	12.88	16.00	12.92	16.05	12.96
Maximum Power Voltage(Vmp/V)	40.66	37.86	40.85	38.05	41.05	38.23	41.25	38.42	41.45	38.60
Maximum Power Current(Imp/A)	15.00	12.28	15.05	12.32	15.10	12.36	15.15	12.40	15.20	12.44
Module Efficiency(%)	22.6		22.8		22.9		23.1		23.3	

* Under Standard Test Conditions (STC) of irradiance of 1000 W/m², spectrum AM 1.5 and cell temperature of 25°C.

* Under Nominal Module Operating Temperature (NMOT), irradiance of 800 W/m², spectrum AM 1.5, ambient temperature 20°C, wind speed 1 m/s.

ELECTRICAL CHARACTERISTICS WITH 10% SOLAR IRRADIATION RATIO (BNPI)

Maximum Power(Pmax/W)	671	677	682	688	693
Open Circuit Voltage(Voc/V)	48.92	49.16	49.40	49.63	49.87
Short Circuit Current(Isc/A)	17.43	17.49	17.55	17.60	17.66
Maximum Power Voltage(Vmp/V)	40.66	40.85	41.05	41.25	41.45
Maximum Power Current(Imp/A)	16.50	16.56	16.61	16.67	16.72

*Rear side power gain:The additional gain from the rear side compared to the power of the front side at the standard test condition.It depends on mounting (structure,height,tilt angle etc.)and albedo of the ground.

OPERATING PARAMETERS

Operational Temperature	-40°C~+85°C
Power Output Tolerance	0~3%
Maximum System Voltage	1500V
Maximum Series Fuse Rating	30A
Nominal Operating Cell Temperature	45±2°C
Protection Class	Class II
Bifaciality	80±5%
Fire Rating	IEC Class A

*The actual test value may be slightly deviated from the technical parameters due to the difference in test methods.

MECHANICAL LOADING

Front Side Maximum Static Loading	5400Pa
Rear Side Maximum Static Loading	2400Pa
Hailstone Test	25mm Hailstone at the speed of 23m/s

TEMPERATURE RATINGS (STC)

Temperature Coefficient of Isc	+0.04%/°C
Temperature Coefficient of Voc	-0.23%/°C
Temperature Coefficient of Pmax	-0.28%/°C



485W

HORAY



HS 199R-108 TC-D Delta N-type Bifacial Modules



SMBB Half-Cell Technology

More uniform current collection capability, reducing the current heat loss of the internal cells.



Higher Output Power

The output power of 108 half-cells monocrystalline modules is up to 485W.



Low Light Features

Higher performance under low light environment.



Harsh Environmental Adaptability

Strict salt spray and ammonia corrosion test by the third party.



N-type With Very Low LID

N-type solar cell has very low LID naturally which can reduce power degradation.

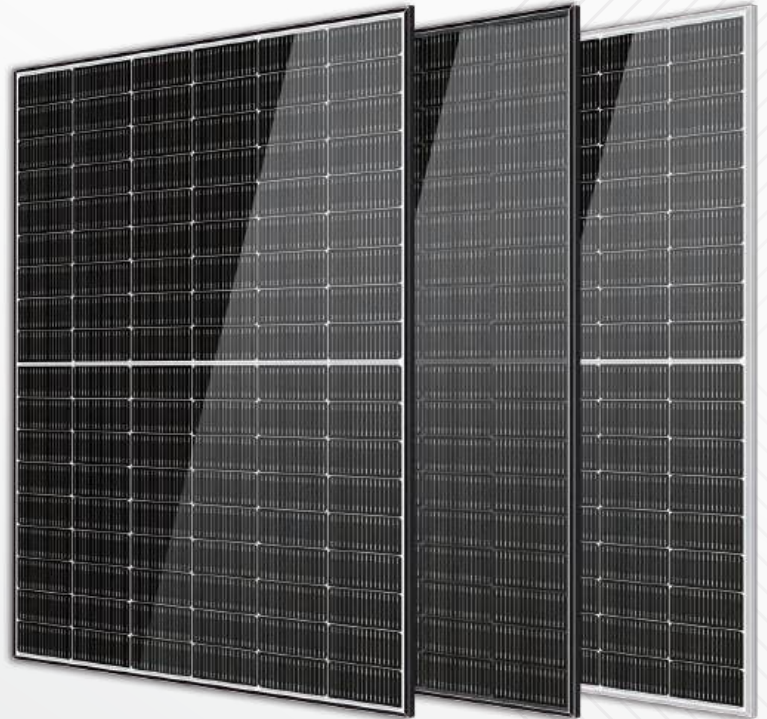

IEC61215:2021

IEC61730:2023

ISO9001:2015 Quality Management System

ISO14001:2015 Environmental Management System

IOS45001:2018 Occupational Health and Safety Management System

CE: Europe Standard

China Quality Certification Centre

Solar Product Certification

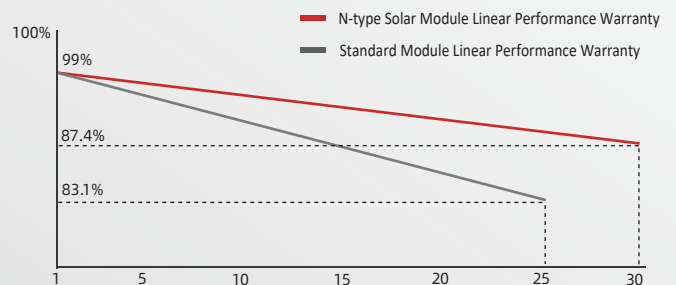
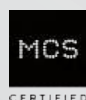

15-year product warranty



30-year linear power output warranty

HEADQUARTER: HORAY SOLAR CO., LTD.

GLOBAL MARKETING AND SERVICE: HORAY SOLAR GMBH

sales@horaysolar.com www.horaysolar.com +86-510 83580688
No.300 Huiming Road, Huishan District, 214177 Wuxi, Jiangsu, P.R. China

info@horaysolar.com www.horaysolar.com
Robert-Bosch-Straße 27-29, 63225 Langen, Germany

MECHANICAL DIAGRAMS

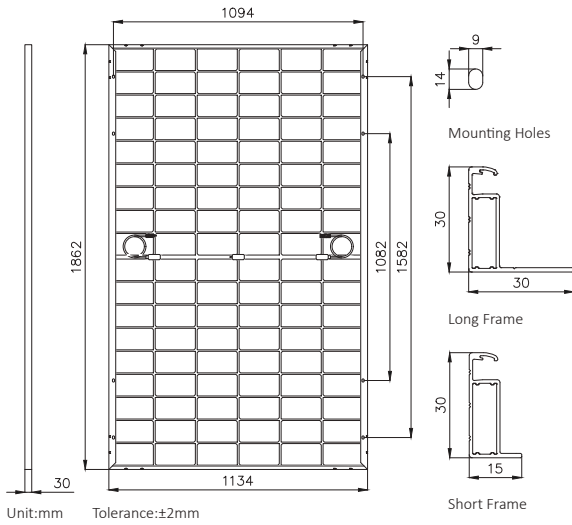

MECHANICAL PARAMETERS

Weight	26.0kg
Dimension	1862×1134×30mm
Cell Orientation	108 (6×18)
Junction Box	IP68, three diodes
Output Cable	4mm ² ,±300mm (length can be customized)
Connector	MC4 compatible
Glass	2.0+2.0mm AR coated heat strengthened glass
Frame	Anodized aluminum alloy frame
Packaging	37pcs per pallet/888pcs per 40'HC

CURVES OF PV MODULE

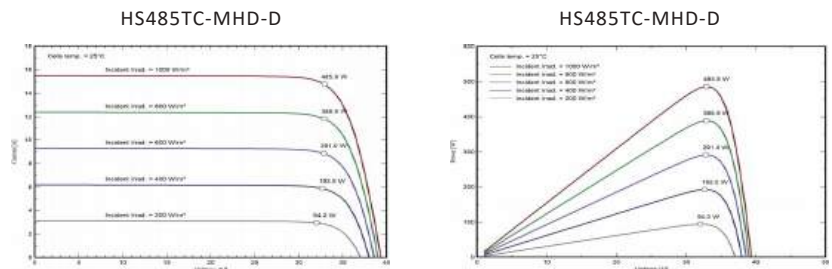

ELECTRICAL CHARACTERISTICS

Module Type	HS465TC-MHD-D		HS470TC-MHD-D		HS475TC-MHD-D		HS480TC-MHD-D		HS485TC-MHD-D	
	STC	NMOT	STC	NMOT	STC	NMOT	STC	NMOT	STC	NMOT
Maximum Power(Pmax/W)	465	354	470	358	475	390	480	366	485	370
Open Circuit Voltage(Voc/V)	38.73	38.73	38.90	38.90	39.08	39.26	39.26	39.26	39.31	39.31
Short Circuit Current(Isc/A)	15.08	11.49	15.17	11.56	15.26	11.33	15.35	11.70	15.49	11.80
Maximum Power Voltage(Vmp/V)	32.85	32.85	33.00	33.00	33.15	33.30	33.30	33.30	33.35	33.35
Maximum Power Current(Imp/A)	14.16	10.79	14.24	10.85	14.33	10.64	14.41	10.98	14.54	11.08
Module Efficiency(%)	22.0		22.3		22.5		22.7		23.0	

* Under Standard Test Conditions (STC) of irradiance of 1000 W/m², spectrum AM 1.5 and cell temperature of 25°C.

* Under Nominal Module Operating Temperature (NMOT), irradiance of 800 W/m², spectrum AM 1.5, ambient temperature 20°C, wind speed 1 m/s.

ELECTRICAL CHARACTERISTICS WITH 10% SOLAR IRRADIATION RATIO (BNPI)

Maximum Power(Pmax/W)	512	517	523	528	534
Open Circuit Voltage(Voc/V)	38.73	38.90	39.08	39.26	39.31
Short Circuit Current(Isc/A)	16.73	16.84	16.94	17.04	17.19
Maximum Power Voltage(Vmp/V)	32.85	33.00	33.15	33.30	33.35
Maximum Power Current(Imp/A)	15.57	15.67	15.76	15.86	16.00

*Rear side power gain:The additional gain from the rear side compared to the power of the front side at the standard test condition.It depends on mounting (structure,height,tilt angle etc.)and albedo of the ground.

OPERATING PARAMETERS

Operational Temperature	-40°C~+85°C
Power Output Tolerance	0~3%
Maximum System Voltage	1500V
Maximum Series Fuse Rating	30A
Nominal Operating Cell Temperature	45±2°C
Protection Class	Class II
Bifaciality	80±5%
Fire Rating	IEC Class A

*The actual test value may be slightly deviated from the technical parameters due to the difference in test methods.

MECHANICAL LOADING

Front Side Maximum Static Loading	5400Pa
Rear Side Maximum Static Loading	2400Pa
Hailstone Test	25mm Hailstone at the speed of 23m/s

TEMPERATURE RATINGS (STC)

Temperature Coefficient of Isc	+0.04%/°C
Temperature Coefficient of Voc	-0.23%/°C
Temperature Coefficient of Pmax	-0.28%/°C



540W

HORAY

TIER1
BloombergNEF

HS 199R-120 TC-D *Delta* N-type Bifacial Modules

N-type
SMBB

SMBB Half-Cell Technology
More uniform current collection capability, reducing the current heat loss of the internal cells.

CONVERSION

Higher Output Power
The output power of 120 half-cells monocrystalline modules is up to 540W.

LOW LIGHT

Low Light Features
Higher performance under low light environment.

RESISTANT

Harsh Environmental Adaptability
Strict salt spray and ammonia corrosion test by the third party.

LID
LOW LID

N-type With Very Low LID
N-type solar cell has very low LID naturally which can reduce power degradation.

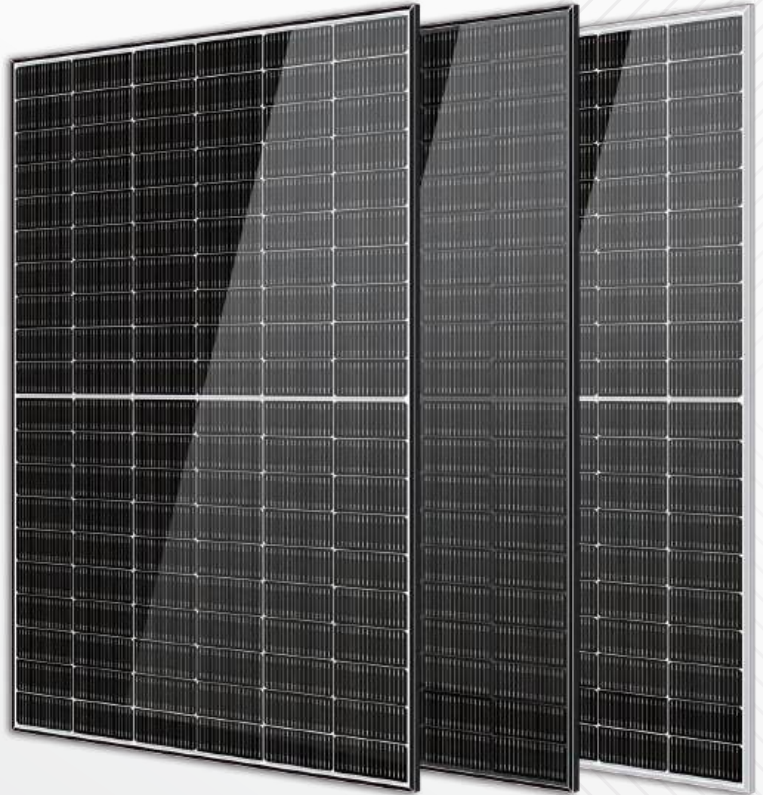

IEC61215:2021

IEC61730:2023

ISO9001:2015 Quality Management System

ISO14001:2015 Environmental Management System

IOS45001:2018 Occupational Health and Safety Management System

CE: Europe Standard

China Quality Certification Centre

Solar Product Certification

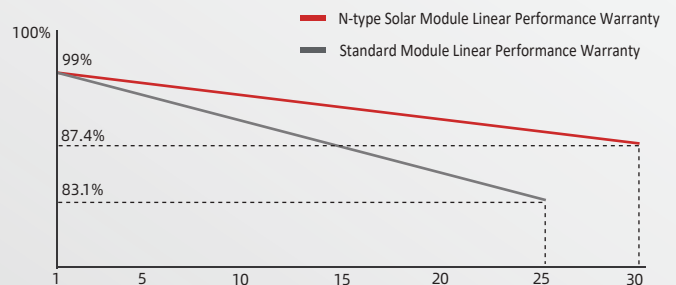

15-year product warranty



30-year linear power output warranty

HEADQUARTER: HORAY SOLAR CO., LTD.

GLOBAL MARKETING AND SERVICE: HORAY SOLAR GMBH

sales@horaysolar.com www.horaysolar.com +86-510 83580688

info@horaysolar.com www.horaysolar.com

No.300 Huiming Road, Huishan District, 214177 Wuxi, Jiangsu, P.R. China

Robert-Bosch-Straße 27-29, 63225 Langen, Germany

MECHANICAL DIAGRAMS

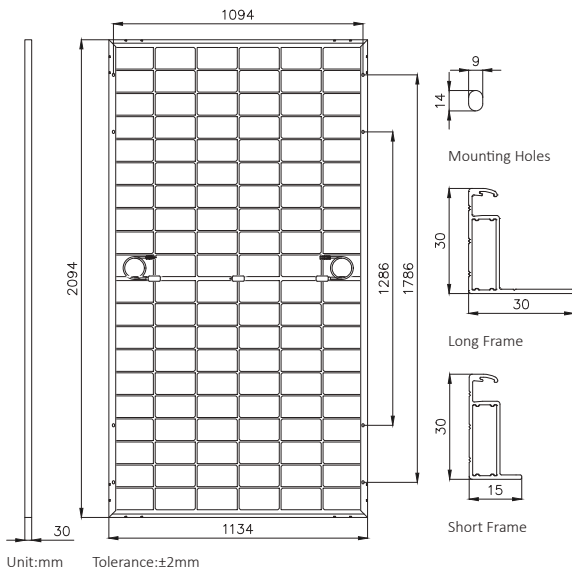

MECHANICAL PARAMETERS

Weight	29.0kg
Dimension	2094×1134×30mm
Cell Orientation	120 (6×20)
Junction Box	IP68, three diodes
Output Cable	4mm ² ,±300mm (length can be customized)
Connector	MC4 compatible
Glass	2.0+2.0mm AR coated heat strengthened glass
Frame	Anodized aluminum alloy frame
Packaging	37pcs per pallet/814pcs per 40'HC

CURVES OF PV MODULE

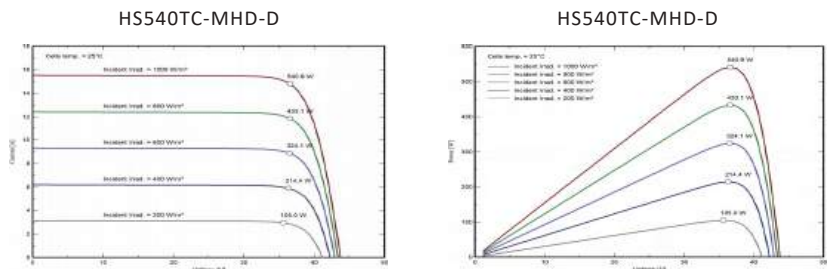

ELECTRICAL CHARACTERISTICS

Module Type	HS520TC-MHD-D		HS525TC-MHD-D		HS530TC-MHD-D		HS535TC-MHD-D		HS540TC-MHD-D	
	STC	NMOT	STC	NMOT	STC	NMOT	STC	NMOT	STC	NMOT
Maximum Power(Pmax/W)	520	396	525	400	530	404	535	408	540	411
Open Circuit Voltage(Voc/V)	43.23	43.23	43.42	43.42	43.62	43.62	43.68	43.68	43.71	43.71
Short Circuit Current(Isc/A)	15.10	11.51	15.18	11.57	15.26	11.62	15.38	11.72	15.51	11.82
Maximum Power Voltage(Vmp/V)	36.67	36.67	36.83	36.83	37.00	37.00	37.05	37.05	37.08	37.08
Maximum Power Current(Imp/A)	14.18	10.81	14.25	10.86	14.32	10.92	14.44	11.00	14.56	11.10
Module Efficiency(%)	22.2		22.5		22.7		22.9		23.1	

* Under Standard Test Conditions (STC) of irradiance of 1000 W/m², spectrum AM 1.5 and cell temperature of 25°C.

* Under Nominal Module Operating Temperature (NMOT), irradiance of 800 W/m², spectrum AM 1.5, ambient temperature 20°C, wind speed 1 m/s.

ELECTRICAL CHARACTERISTICS WITH 10% SOLAR IRRADIATION RATIO (BNPI)

Maximum Power(Pmax/W)	572	578	583	589	594
Open Circuit Voltage(Voc/V)	43.23	43.42	43.62	43.68	43.71
Short Circuit Current(Isc/A)	16.61	16.70	16.78	16.92	17.06
Maximum Power Voltage(Vmp/V)	36.67	36.83	37.00	37.05	37.08
Maximum Power Current(Imp/A)	15.60	15.68	15.76	15.88	16.02

*Rear side power gain:The additional gain from the rear side compared to the power of the front side at the standard test condition.It depends on mounting (structure,height,tilt angle etc.)and albedo of the ground.

OPERATING PARAMETERS

Operational Temperature	-40°C~+85°C
Power Output Tolerance	0~3%
Maximum System Voltage	1500V
Maximum Series Fuse Rating	30A
Nominal Operating Cell Temperature	45±2°C
Protection Class	Class II
Bifaciality	80±5%
Fire Rating	IEC Class A

*The actual test value may be slightly deviated from the technical parameters due to the difference in test methods.

MECHANICAL LOADING

Front Side Maximum Static Loading	5400Pa
Rear Side Maximum Static Loading	2400Pa
Hailstone Test	25mm Hailstone at the speed of 23m/s

TEMPERATURE RATINGS (STC)

Temperature Coefficient of Isc	+0.04%/°C
Temperature Coefficient of Voc	-0.23%/°C
Temperature Coefficient of Pmax	-0.28%/°C



590W

HORAY

TIER1
BloombergNEF

HS **199R-132** TC-D *Delta* N-type Bifacial Modules

N-type
SMBB

SMBB Half-Cell Technology
More uniform current collection capability, reducing the current heat loss of the internal cells.

CONVERSION

Higher Output Power
The output power of 132 half-cells monocrystalline modules is up to 590W.

LOW LIGHT

Low Light Features
Higher performance under low light environment.

RESISTANT

Harsh Environmental Adaptability
Strict salt spray and ammonia corrosion test by the third party.

LID
LOW LID

N-type With Very Low LID
N-type solar cell has very low LID naturally which can reduce power degradation.

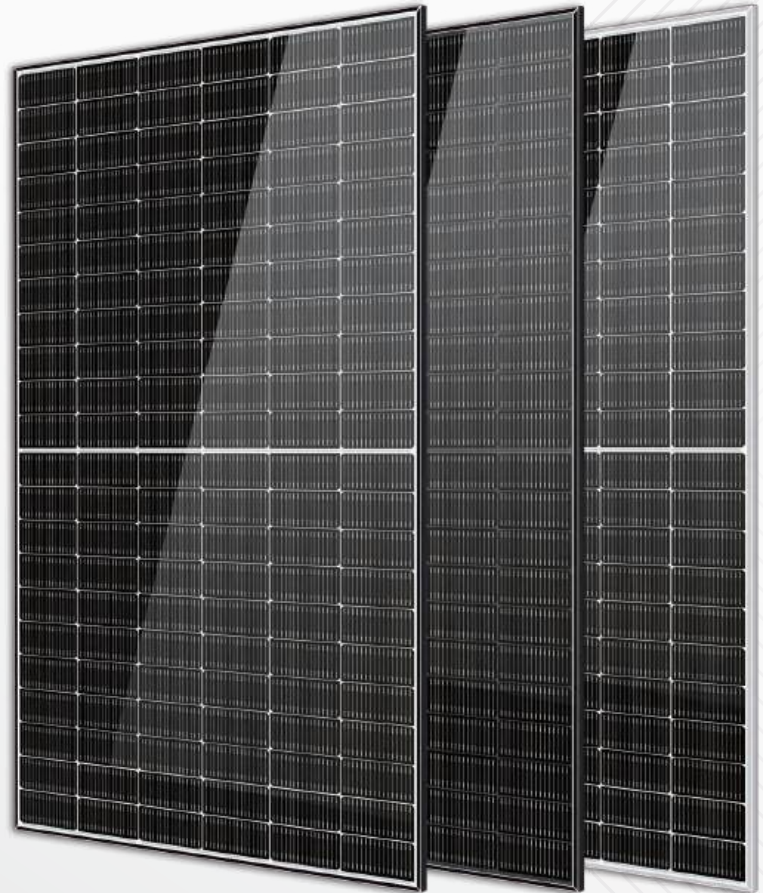

- IEC61215:2021
- IEC61730:2023
- ISO9001:2015 Quality Management System
- ISO14001:2015 Environmental Management System
- IOS45001:2018 Occupational Health and Safety Management System
- CE: Europe Standard
- China Quality Certification Centre
- Solar Product Certification

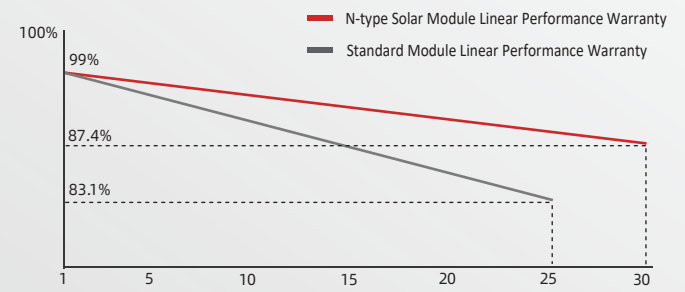

15 15-year product warranty

30 30-year linear power output warranty

HEADQUARTER: HORAY SOLAR CO., LTD. GLOBAL MARKETING AND SERVICE: HORAY SOLAR GMBH

sales@horaysolar.com www.horaysolar.com +86-510 83580688
No.300 Huiming Road, Huishan District, 214177 Wuxi, Jiangsu, P.R. China

info@horaysolar.com www.horaysolar.com
Robert-Bosch-Straße 27-29, 63225 Langen, Germany

MECHANICAL DIAGRAMS

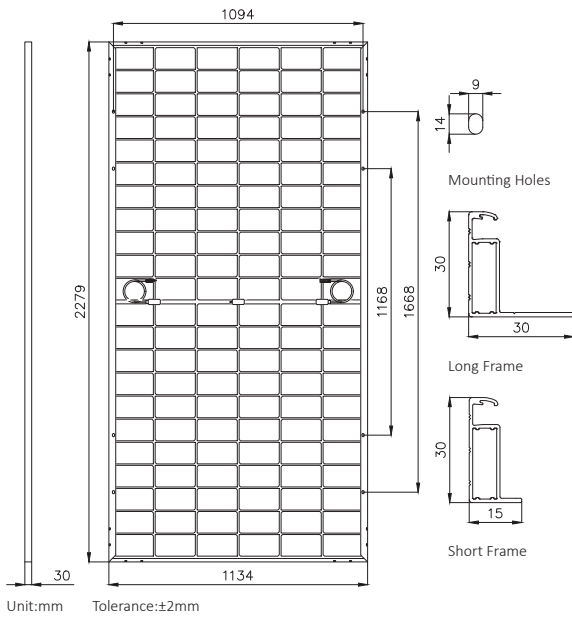

MECHANICAL PARAMETERS

Weight	31.5kg
Dimension	2279×1134×30mm
Cell Orientation	132 (6×22)
Junction Box	IP68, three diodes
Output Cable	4mm ² ,±300mm (length can be customized)
Connector	MC4 compatible
Glass	2.0+2.0mm AR coated heat strengthened glass
Frame	Anodized aluminum alloy frame
Packaging	37pcs per pallet/740pcs per 40'HC

CURVES OF PV MODULE

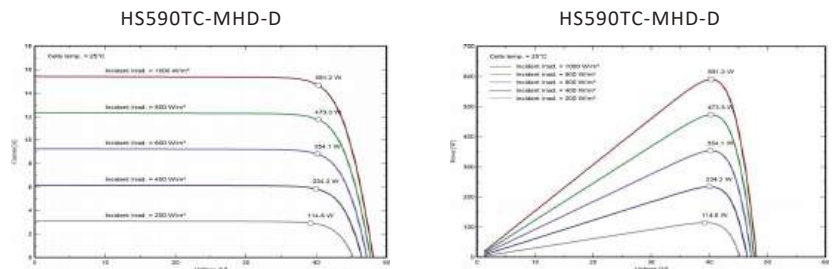

ELECTRICAL CHARACTERISTICS

Module Type	HS570TC-MHD-D		HS575TC-MHD-D		HS580TC-MHD-D		HS585TC-MHD-D		HS590TC-MHD-D	
	STC	NMOT	STC	NMOT	STC	NMOT	STC	NMOT	STC	NMOT
Maximum Power(Pmax/W)	570	434	575	438	580	442	585	446	590	450
Open Circuit Voltage(Voc/V)	47.55	47.55	47.76	47.76	47.98	47.98	48.05	48.05	48.08	48.08
Short Circuit Current(Isc/A)	15.05	11.47	15.11	11.52	15.18	11.56	15.29	11.65	15.41	11.74
Maximum Power Voltage(Vmp/V)	40.33	40.33	40.52	40.52	40.70	40.70	40.76	40.76	40.79	40.79
Maximum Power Current(Imp/A)	14.13	10.77	14.19	10.81	14.25	10.86	14.35	10.94	14.47	11.02
Module Efficiency(%)	22.2		22.4		22.6		22.8		23.0	

* Under Standard Test Conditions (STC) of irradiance of 1000 W/m², spectrum AM 1.5 and cell temperature of 25°C.

* Under Nominal Module Operating Temperature (NMOT), irradiance of 800 W/m², spectrum AM 1.5, ambient temperature 20°C, wind speed 1 m/s.

ELECTRICAL CHARACTERISTICS WITH 10% SOLAR IRRADIATION RATIO (BNPI)

Maximum Power(Pmax/W)	627	633	638	644	649
Open Circuit Voltage(Voc/V)	47.55	47.76	47.98	48.05	48.08
Short Circuit Current(Isc/A)	16.56	16.63	16.69	16.82	16.95
Maximum Power Voltage(Vmp/V)	40.33	40.52	40.70	40.76	40.79
Maximum Power Current(Imp/A)	15.55	15.61	15.68	15.79	15.91

*Rear side power gain:The additional gain from the rear side compared to the power of the front side at the standard test condition.It depends on mounting (structure,height,tilt angle etc.)and albedo of the ground.

OPERATING PARAMETERS

Operational Temperature	-40°C~+85°C
Power Output Tolerance	0~3%
Maximum System Voltage	1500V
Maximum Series Fuse Rating	30A
Nominal Operating Cell Temperature	45±2°C
Protection Class	Class II
Bifaciality	80±5%
Fire Rating	IEC Class A

*The actual test value may be slightly deviated from the technical parameters due to the difference in test methods.

MECHANICAL LOADING

Front Side Maximum Static Loading	5400Pa
Rear Side Maximum Static Loading	2400Pa
Hailstone Test	25mm Hailstone at the speed of 23m/s

TEMPERATURE RATINGS (STC)

Temperature Coefficient of Isc	+0.04%/°C
Temperature Coefficient of Voc	-0.23%/°C
Temperature Coefficient of Pmax	-0.28%/°C



650W

HORAY

TIER1
BloombergNEF

HS **199R-144** TC-D *Delta* N-type Bifacial Modules

N-type
SMBB
SMBB Half-Cell Technology
More uniform current collection capability, reducing the current heat loss of the internal cells.

CONVERSION
Higher Output Power
The output power of 144 half-cells monocrystalline modules is up to 650W.

LOW LIGHT
Low Light Features
Higher performance under low light environment.

RESISTANT
Harsh Environmental Adaptability
Strict salt spray and ammonia corrosion test by the third party.

LOW LID
N-type With Very Low LID
N-type solar cell has very low LID naturally which can reduce power degradation.

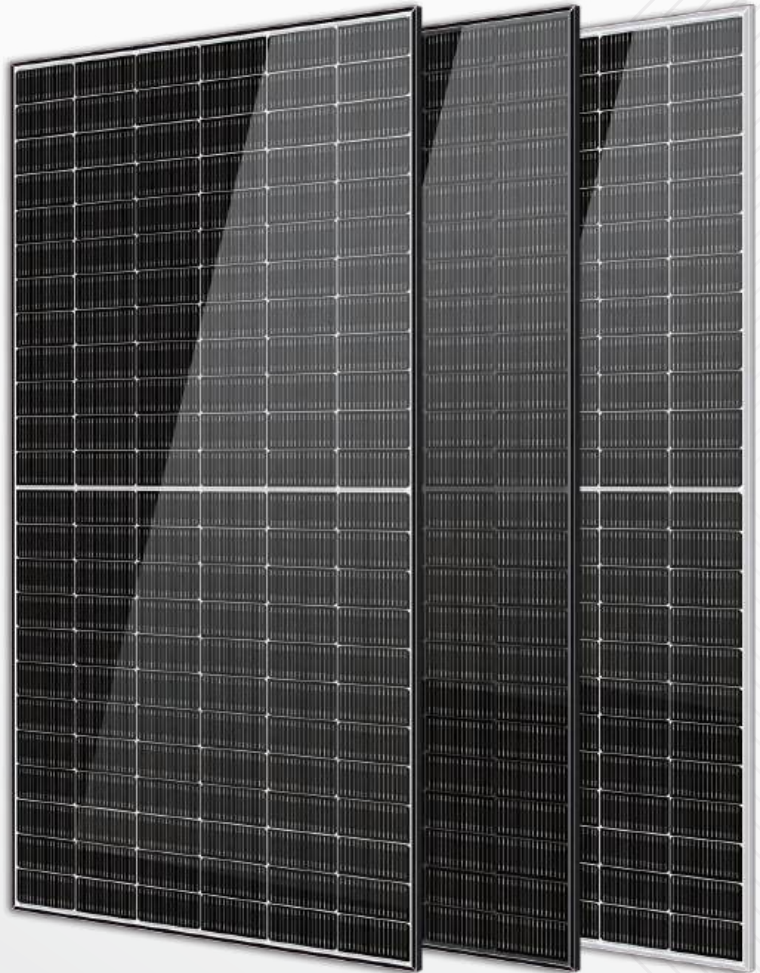

IEC61215:2021

IEC61730:2023

ISO9001:2015 Quality Management System

ISO14001:2015 Environmental Management System

IOS45001:2018 Occupational Health and Safety Management System

CE: Europe Standard

China Quality Certification Centre

Solar Product Certification

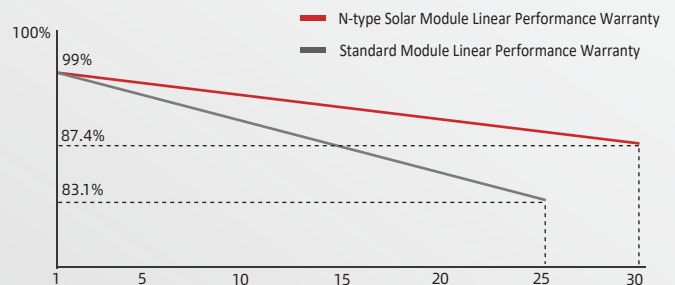
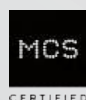

15-year product warranty



30-year linear power output warranty

HEADQUARTER: HORAY SOLAR CO., LTD.

GLOBAL MARKETING AND SERVICE: HORAY SOLAR GMBH

sales@horaysolar.com www.horaysolar.com +86-510 83580688
No.300 Huiming Road, Huishan District, 214177 Wuxi, Jiangsu, P.R. China

info@horaysolar.com www.horaysolar.com
Robert-Bosch-Straße 27-29, 63225 Langen, Germany

MECHANICAL DIAGRAMS

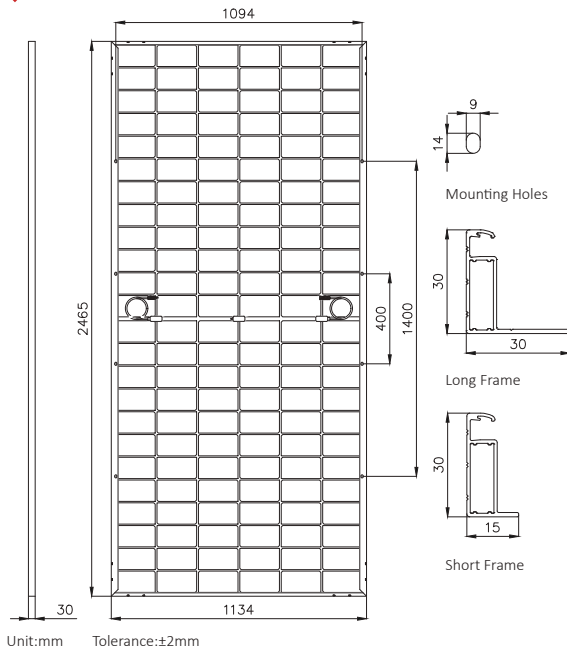

MECHANICAL PARAMETERS

Weight	34.5kg
Dimension	2465×1134×30mm
Cell Orientation	144 (6×24)
Junction Box	IP68, three diodes
Output Cable	4mm ² ,±300mm (length can be customized)
Connector	MC4 compatible
Glass	2.0+2.0mm AR coated heat strengthened glass
Frame	Anodized aluminum alloy frame
Packaging	36pcs per pallet/648pcs per 40'HC

CURVES OF PV MODULE

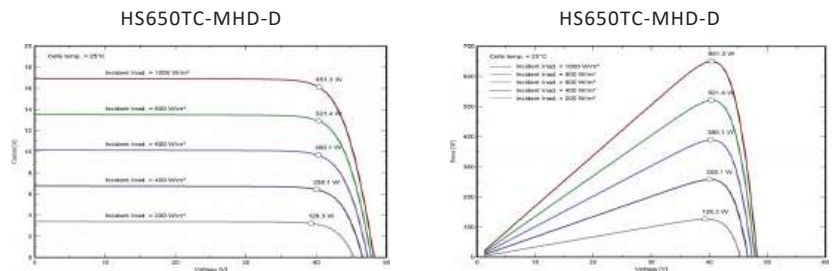

ELECTRICAL CHARACTERISTICS

Module Type	HS630TC-MHD-D		HS635TC-MHD-D		HS640TC-MHD-D		HS645TC-MHD-D		HS650TC-MHD-D	
	STC	NMOT	STC	NMOT	STC	NMOT	STC	NMOT	STC	NMOT
Maximum Power(Pmax/W)	630	480	635	484	640	488	645	491	650	495
Open Circuit Voltage(Voc/V)	47.98	47.98	48.05	48.05	48.08	48.08	48.16	48.16	48.20	48.20
Short Circuit Current(Isc/A)	16.49	12.56	16.59	12.64	16.71	12.73	16.81	12.81	16.93	12.90
Maximum Power Voltage(Vmp/V)	40.70	40.70	40.76	40.76	40.79	40.79	40.85	40.85	40.89	40.89
Maximum Power Current(Imp/A)	15.48	11.80	15.58	11.87	15.69	11.96	15.79	12.03	15.90	12.11
Module Efficiency(%)	22.5		22.7		22.9		23.1		23.3	

* Under Standard Test Conditions (STC) of irradiance of 1000 W/m², spectrum AM 1.5 and cell temperature of 25°C.

* Under Nominal Module Operating Temperature (NMOT), irradiance of 800 W/m², spectrum AM 1.5, ambient temperature 20°C, wind speed 1 m/s.

ELECTRICAL CHARACTERISTICS WITH 10% SOLAR IRRADIATION RATIO (BNPI)

Maximum Power(Pmax/W)	693	699	704	710	715
Open Circuit Voltage(Voc/V)	47.98	48.05	48.08	48.16	48.20
Short Circuit Current(Isc/A)	18.13	18.25	18.38	18.50	18.62
Maximum Power Voltage(Vmp/V)	40.70	40.76	40.79	40.85	40.89
Maximum Power Current(Imp/A)	17.03	17.14	17.26	17.37	17.49

*Rear side power gain:The additional gain from the rear side compared to the power of the front side at the standard test condition.It depends on mounting (structure,height,tilt angle etc.)and albedo of the ground.

OPERATING PARAMETERS

Operational Temperature	-40°C~+85°C
Power Output Tolerance	0~3%
Maximum System Voltage	1500V
Maximum Series Fuse Rating	30A
Nominal Operating Cell Temperature	45±2°C
Protection Class	Class II
Bifaciality	80±5%
Fire Rating	IEC Class A

*The actual test value may be slightly deviated from the technical parameters due to the difference in test methods.

MECHANICAL LOADING

Front Side Maximum Static Loading	5400Pa
Rear Side Maximum Static Loading	2400Pa
Hailstone Test	25mm Hailstone at the speed of 23m/s

TEMPERATURE RATINGS (STC)

Temperature Coefficient of Isc	+0.04%/°C
Temperature Coefficient of Voc	-0.23%/°C
Temperature Coefficient of Pmax	-0.28%/°C



700~730 Watt

HORAY



HS **210-132** TC-D *Galaxy* N-type Bifacial Modules



SMBB Half-Cell Technology

More uniform current collection capability, reducing the current heat loss of the internal cells.



Higher Output Power

The output power of 132 half-cells monocrystalline modules is up to 730W.



Low Light Features

Higher performance under low light environment.



Harsh Environmental Adaptability

Strict salt spray and ammonia corrosion test by the third party.



N-type With Very Low LID

N-type solar cell has very low LID naturally which can reduce power degradation.

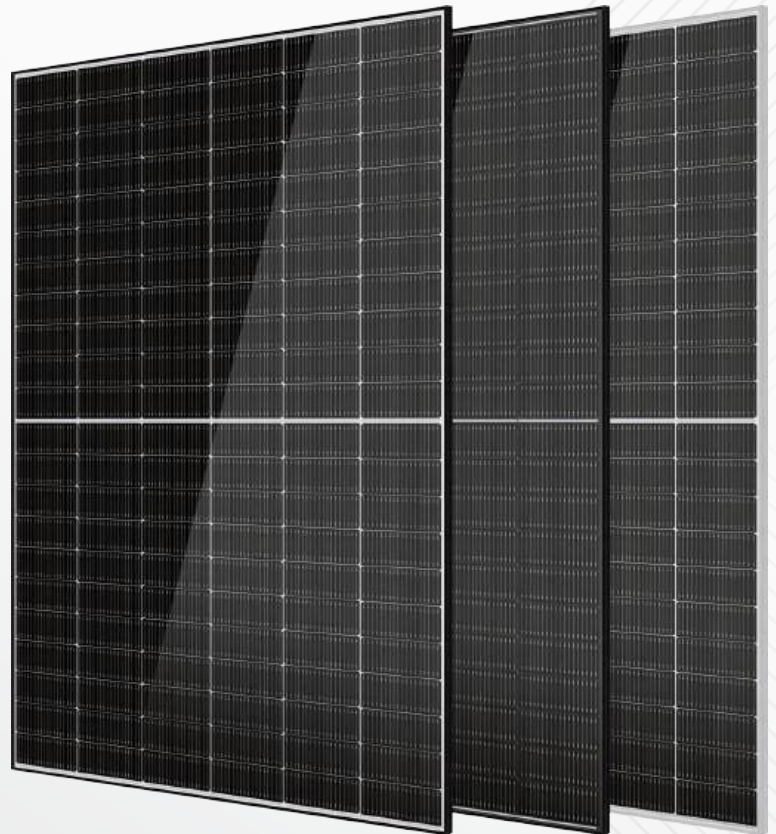

IEC61215:2021

IEC61730:2023

ISO9001:2015 Quality Management System

ISO14001:2015 Environmental Management System

ISO45001:2018 Occupational Health and Safety Management System

CE: Europe Standard

China Quality Certification Centre

Solar Product Certification

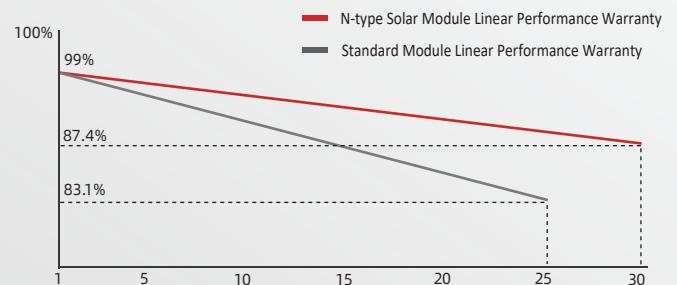

15-year product warranty



30-year linear power output warranty

HEADQUARTER: HORAY SOLAR CO., LTD.

GLOBAL MARKETING AND SERVICE: HORAY SOLAR GMBH

sales@horaysolar.com www.horaysolar.com +86-510 83580688

info@horaysolar.com www.horaysolar.com

No.300 Huiming Road, Huishan District, 214177 Wuxi, Jiangsu, P.R. China

Robert-Bosch-Straße 27-29, 63225 Langen, Germany

MECHANICAL DIAGRAMS

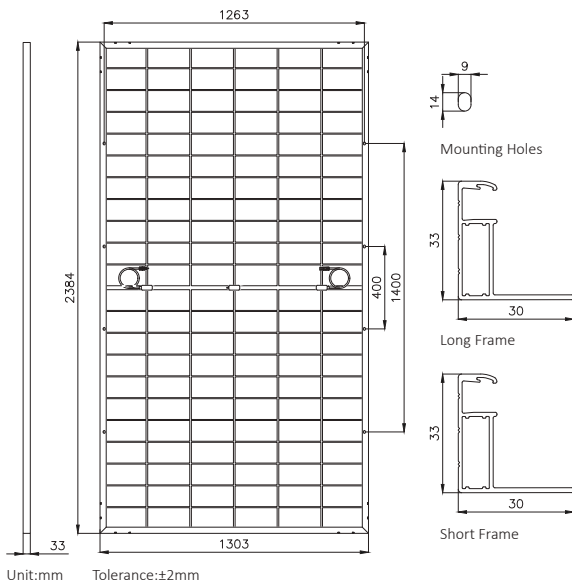

MECHANICAL PARAMETERS

Weight	38.5kg
Dimension	2384×1303×33mm
Cell Orientation	132(6×22)
Junction Box	IP68, three diodes
Output Cable	4mm ² ,±300mm (length can be customized)
Connector	MC4 compatible
Glass	2.0+2.0mm AR coated heat strengthened glass
Frame	Anodized aluminum alloy frame
Packaging	33pcs per pallet/594pcs per 40'HC

CURVES OF PV MODULE

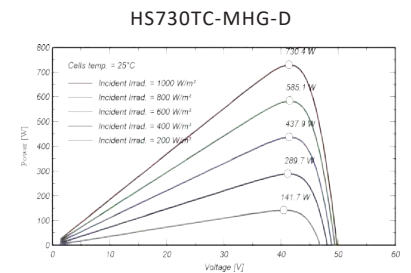
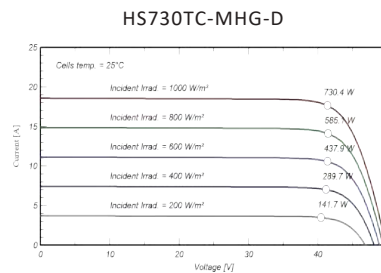

ELECTRICAL CHARACTERISTICS

Module Type	HS700TC-MHG-D		HS705TC-MHG-D		HS710TC-MHG-D		HS715TC-MHG-D		HS720TC-MHG-D		HS725TC-MHG-D		HS730TC-MHG-D	
	STC	NMOT	STC	NMOT	STC	NMOT	STC	NMOT	STC	NMOT	STC	NMOT	STC	NMOT
Maximum Power(Pmax/W)	700	535	705	539	710	543	715	547	720	551	725	555	730	559
Open Circuit Voltage(Voc/V)	48.75	46.10	48.80	46.30	49.00	46.50	49.20	46.70	49.40	46.90	49.60	47.10	49.80	47.30
Short Circuit Current(Isc/A)	18.27	14.71	18.36	14.76	18.40	14.83	18.44	14.86	18.49	14.90	18.52	14.96	18.56	15.01
Maximum Power Voltage(Vmp/V)	40.61	38.20	40.70	38.35	40.90	38.50	41.10	38.65	41.30	38.80	41.50	38.95	41.70	39.10
Maximum Power Current(Imp/A)	17.24	14.01	17.32	14.05	17.36	14.10	17.40	14.15	17.44	14.20	17.47	14.25	17.51	14.30
Module Efficiency(%)	22.5		22.7		22.9		23.0		23.2		23.3		23.5	

* Under Standard Test Conditions (STC) of irradiance of 1000 W/m², spectrum AM 1.5 and cell temperature of 25°C.

* Under Nominal Module Operating Temperature (NMOT), irradiance of 800 W/m², spectrum AM 1.5, ambient temperature 20°C, wind speed 1 m/s.

ELECTRICAL CHARACTERISTICS WITH 10% SOLAR IRRADIATION RATIO (BNPI)

Maximum Power(Pmax/W)	770	776	781	786	791	796	801
Open Circuit Voltage(Voc/V)	48.75	48.80	49.00	49.20	49.40	49.60	49.80
Short Circuit Current(Isc/A)	20.09	20.21	20.24	20.27	20.30	20.33	20.36
Maximum Power Voltage(Vmp/V)	40.61	40.70	40.90	41.10	41.30	41.50	41.70
Maximum Power Current(Imp/A)	18.96	19.07	19.10	19.12	19.15	19.18	19.21

*Rear side power gain:The additional gain from the rear side compared to the power of the front side at the standard test condition.It depends on mounting (structure,height,tilt angle etc.)and albedo of the ground.

OPERATING PARAMETERS

Operational Temperature	-40°C~+85°C
Power Output Tolerance	0~3%
Maximum System Voltage	1500V
Maximum Series Fuse Rating	30A
Nominal Operating Cell Temperature	45±2°C
Protection Class	Class II
Bifaciality	80±5%
Fire Rating	IEC Class A

*The actual test value may be slightly deviated from the technical parameters due to the difference in test methods.

MECHANICAL LOADING

Front Side Maximum Static Loading	5400Pa
Rear Side Maximum Static Loading	2400Pa
Hailstone Test	25mm Hailstone at the speed of 23m/s

TEMPERATURE RATINGS (STC)

Temperature Coefficient of Isc	+0.04%/°C
Temperature Coefficient of Voc	-0.23%/°C
Temperature Coefficient of Pmax	-0.28%/°C



700~730 Watt

HORAY

TIER1
BloombergNEF

HS **210-132** TC-D *Galaxy* N-type Bifacial Modules

N-type
SMBB
SMBB Half-Cell Technology
More uniform current collection capability, reducing the current heat loss of the internal cells.

CONVERSION
Higher Output Power
The output power of 132 half-cells monocrystalline modules is up to 730W.

LOW LIGHT
Low Light Features
Higher performance under low light environment.

RESISTANT
Harsh Environmental Adaptability
Strict salt spray and ammonia corrosion test by the third party.

LID
LOW LID
N-type With Very Low LID
N-type solar cell has very low LID naturally which can reduce power degradation.

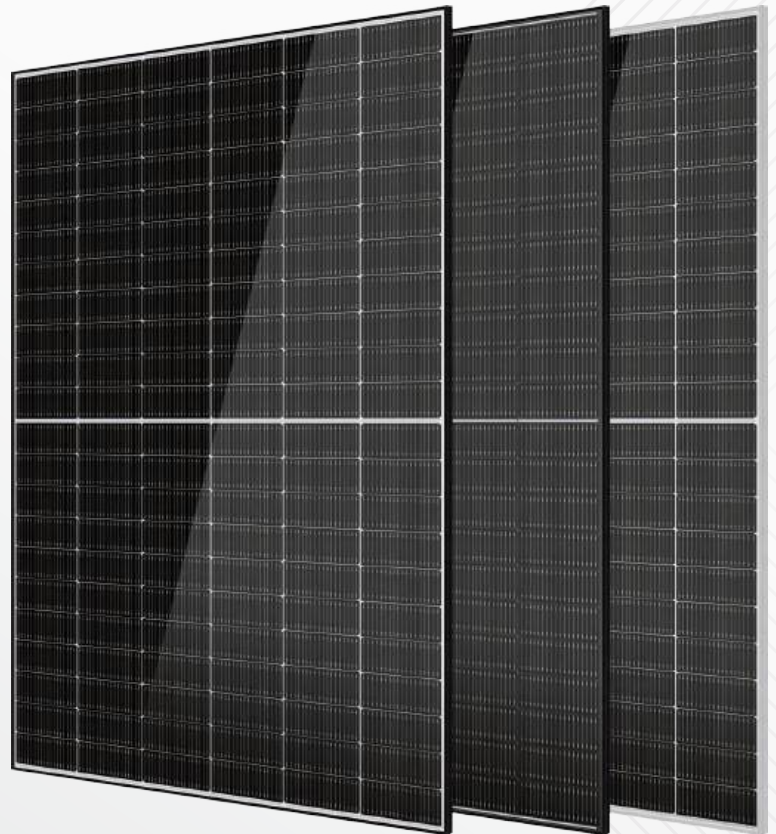

IEC61215:2021

IEC61730:2023

ISO9001:2015 Quality Management System

ISO14001:2015 Environmental Management System

ISO45001:2018 Occupational Health and Safety Management System

CE: Europe Standard

China Quality Certification Centre

Solar Product Certification

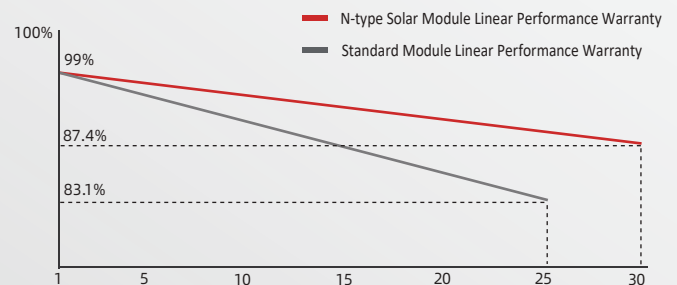

15-year product warranty



30-year linear power output warranty

HEADQUARTER: HORAY SOLAR CO., LTD.

GLOBAL MARKETING AND SERVICE: HORAY SOLAR GMBH

sales@horaysolar.com www.horaysolar.com +86-510 83580688
No.300 Huiming Road, Huishan District, 214177 Wuxi, Jiangsu, P.R. China

info@horaysolar.com www.horaysolar.com
Robert-Bosch-Straße 27-29, 63225 Langen, Germany

MECHANICAL DIAGRAMS

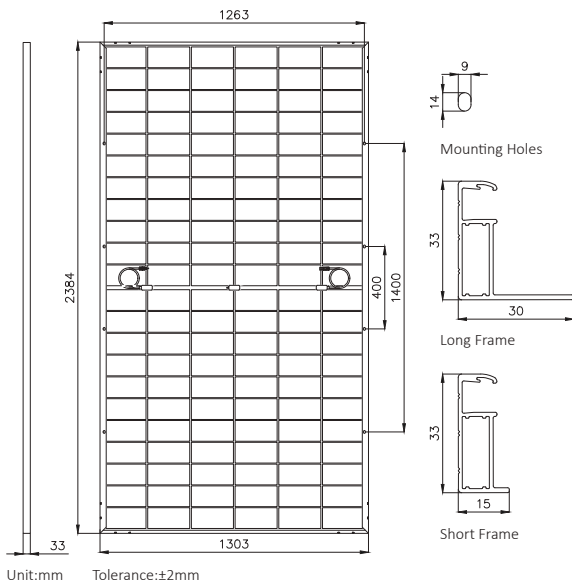

MECHANICAL PARAMETERS

Weight	38.5kg
Dimension	2384×1303×33mm
Cell Orientation	132(6×22)
Junction Box	IP68, three diodes
Output Cable	4mm ² ,±300mm (length can be customized)
Connector	MC4 compatible
Glass	2.0+2.0mm AR coated heat strengthened glass
Frame	Anodized aluminum alloy frame
Packaging	33pcs per pallet/594pcs per 40'HC

CURVES OF PV MODULE

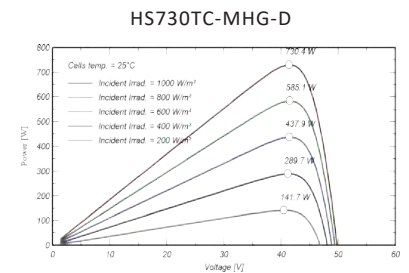
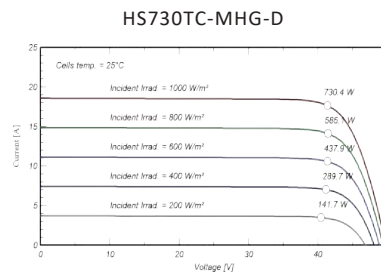

ELECTRICAL CHARACTERISTICS

Module Type	HS700TC-MHG-D		HS705TC-MHG-D		HS710TC-MHG-D		HS715TC-MHG-D		HS720TC-MHG-D		HS725TC-MHG-D		HS730TC-MHG-D	
	STC	NMOT	STC	NMOT	STC	NMOT	STC	NMOT	STC	NMOT	STC	NMOT	STC	NMOT
Maximum Power(Pmax/W)	700	535	705	539	710	543	715	547	720	551	725	555	730	559
Open Circuit Voltage(Voc/V)	48.75	46.10	48.80	46.30	49.00	46.50	49.20	46.70	49.40	46.90	49.60	47.10	49.80	47.30
Short Circuit Current(Isc/A)	18.27	14.71	18.36	14.76	18.40	14.83	18.44	14.86	18.49	14.90	18.52	14.96	18.56	15.01
Maximum Power Voltage(Vmp/V)	40.61	38.20	40.70	38.35	40.90	38.50	41.10	38.65	41.30	38.80	41.50	38.95	41.70	39.10
Maximum Power Current(Imp/A)	17.24	14.01	17.32	14.05	17.36	14.10	17.40	14.15	17.44	14.20	17.47	14.25	17.51	14.30
Module Efficiency(%)	22.5		22.7		22.9		23.0		23.2		23.3		23.5	

* Under Standard Test Conditions (STC) of irradiance of 1000 W/m², spectrum AM 1.5 and cell temperature of 25°C.

* Under Nominal Module Operating Temperature (NMOT), irradiance of 800 W/m², spectrum AM 1.5, ambient temperature 20°C, wind speed 1 m/s.

ELECTRICAL CHARACTERISTICS WITH 10% SOLAR IRRADIATION RATIO (BNPI)

Maximum Power(Pmax/W)	770	776	781	786	791	796	801
Open Circuit Voltage(Voc/V)	48.75	48.80	49.00	49.20	49.40	49.60	49.80
Short Circuit Current(Isc/A)	20.09	20.21	20.24	20.27	20.30	20.33	20.36
Maximum Power Voltage(Vmp/V)	40.61	40.70	40.90	41.10	41.30	41.50	41.70
Maximum Power Current(Imp/A)	18.96	19.07	19.10	19.12	19.15	19.18	19.21

*Rear side power gain:The additional gain from the rear side compared to the power of the front side at the standard test condition.It depends on mounting (structure,height,tilt angle etc.)and albedo of the ground.

OPERATING PARAMETERS

Operational Temperature	-40°C~+85°C
Power Output Tolerance	0~3%
Maximum System Voltage	1500V
Maximum Series Fuse Rating	30A
Nominal Operating Cell Temperature	45±2°C
Protection Class	Class II
Bifaciality	80±5%
Fire Rating	IEC Class A

*The actual test value may be slightly deviated from the technical parameters due to the difference in test methods.

MECHANICAL LOADING

Front Side Maximum Static Loading	5400Pa
Rear Side Maximum Static Loading	2400Pa
Hailstone Test	25mm Hailstone at the speed of 23m/s

TEMPERATURE RATINGS (STC)

Temperature Coefficient of Isc	+0.04%/°C
Temperature Coefficient of Voc	-0.23%/°C
Temperature Coefficient of Pmax	-0.28%/°C



720W

HORAY



HS 210-132 TC-D Galaxy N-type Bifacial Modules

N-type SMBB **SMBB Half-Cell Technology**
 More uniform current collection capability, reducing the current heat loss of the internal cells.

CONVERSION **Higher Output Power**
 The output power of 132 half-cells monocrystalline modules is up to 720W.

LOW LIGHT **Low Light Features**
 Higher performance under low light environment.

RESISTANT **Harsh Environmental Adaptability**
 Strict salt spray and ammonia corrosion test by the third party.

LOW LID **N-type With Very Low LID**
 N-type solar cell has very low LID naturally which can reduce power degradation.

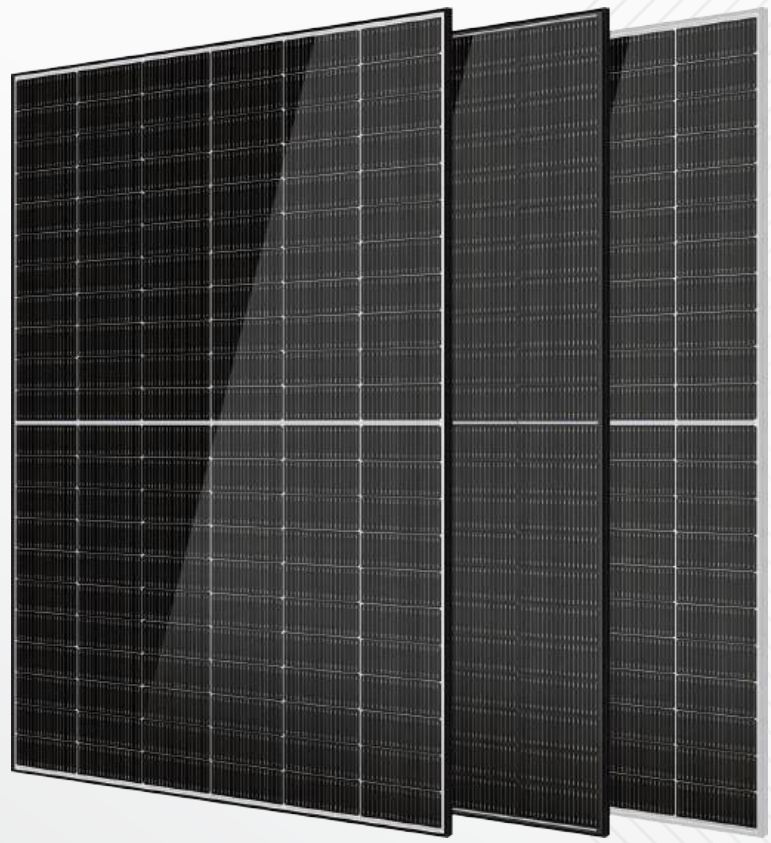

- IEC61215:2021
- IEC61730:2023
- ISO9001:2015 Quality Management System
- ISO14001:2015 Environmental Management System
- IOS45001:2018 Occupational Health and Safety Management System
- CE: Europe Standard
- China Quality Certification Centre
- Solar Product Certification

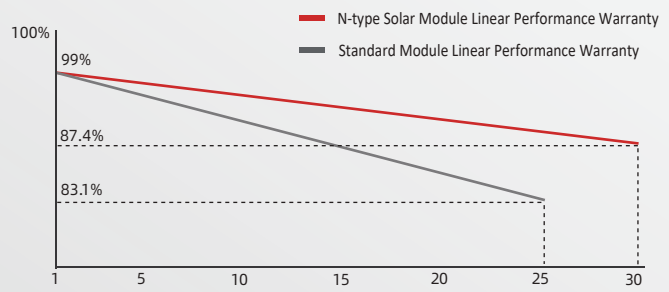

15 15-year product warranty

30 30-year linear power output warranty

HEADQUARTER: HORAY SOLAR CO., LTD. GLOBAL MARKETING AND SERVICE: HORAY SOLAR GMBH

sales@horaysolar.com www.horaysolar.com +86-510 83580688
 No.300 Huiming Road, Huishan District, 214177 Wuxi, Jiangsu, P.R. China

info@horaysolar.com www.horaysolar.com
 Robert-Bosch-Straße 27-29, 63225 Langen, Germany

MECHANICAL DIAGRAMS

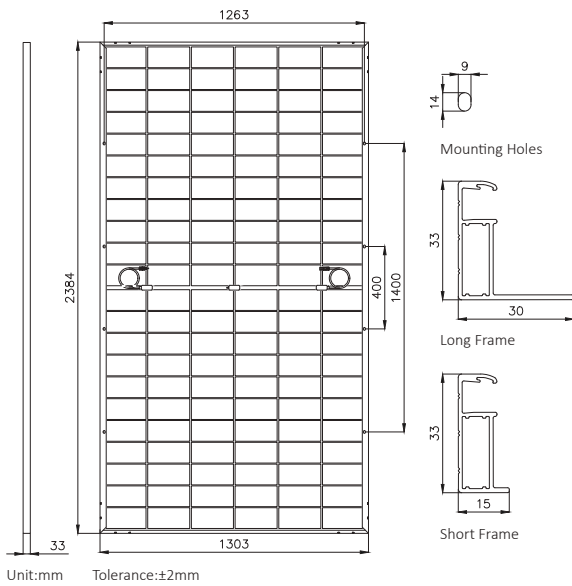

MECHANICAL PARAMETERS

Weight	38.5kg
Dimension	2384×1303×33mm
Cell Orientation	132(6×22)
Junction Box	IP68, three diodes
Output Cable	4mm ² ,±300mm (length can be customized)
Connector	MC4 compatible
Glass	2.0+2.0mm AR coated heat strengthened glass
Frame	Anodized aluminum alloy frame
Packaging	33pcs per pallet/594pcs per 40'HC

CURVES OF PV MODULE

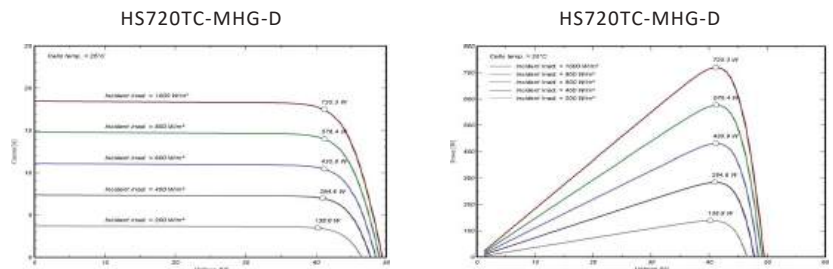

ELECTRICAL CHARACTERISTICS

Module Type	HS680TC-MHG-D		HS690TC-MHG-D		HS700TC-MHG-D		HS710TC-MHG-D		HS720TC-MHG-D	
	STC	NMOT	STC	NMOT	STC	NMOT	STC	NMOT	STC	NMOT
Maximum Power(Pmax/W)	680	520	690	528	700	534	710	543	720	551
Open Circuit Voltage(Voc/V)	47.80	45.41	48.20	45.79	48.60	46.10	49.00	46.50	49.40	46.90
Short Circuit Current(Isc/A)	18.15	14.63	18.23	14.70	18.32	14.76	18.40	14.83	18.49	14.90
Maximum Power Voltage(Vmp/V)	39.70	37.32	40.10	37.69	40.50	38.00	40.90	38.50	41.30	38.80
Maximum Power Current(Imp/A)	17.13	13.94	17.21	14.01	17.29	14.04	17.36	14.12	17.44	14.19
Module Efficiency(%)	21.9		22.2		22.5		22.9		23.2	

* Under Standard Test Conditions (STC) of irradiance of 1000 W/m², spectrum AM 1.5 and cell temperature of 25°C.

* Under Nominal Module Operating Temperature (NMOT), irradiance of 800 W/m², spectrum AM 1.5, ambient temperature 20°C, wind speed 1 m/s.

ELECTRICAL CHARACTERISTICS WITH 10% SOLAR IRRADIATION RATIO (BNPI)

Maximum Power(Pmax/W)	754	765	776	787	798
Open Circuit Voltage(Voc/V)	47.80	48.20	48.60	49.00	49.40
Short Circuit Current(Isc/A)	20.12	20.21	20.30	20.39	20.49
Maximum Power Voltage(Vmp/V)	39.70	40.10	40.50	40.90	41.30
Maximum Power Current(Imp/A)	18.98	19.07	19.15	19.23	19.32

*Rear side power gain:The additional gain from the rear side compared to the power of the front side at the standard test condition.It depends on mounting (structure,height,tilt angle etc.)and albedo of the ground.

OPERATING PARAMETERS

Operational Temperature	-40°C~+85°C
Power Output Tolerance	0~3%
Maximum System Voltage	1500V
Maximum Series Fuse Rating	30A
Nominal Operating Cell Temperature	45±2°C
Protection Class	Class II
Bifaciality	80±5%
Fire Rating	IEC Class A

*The actual test value may be slightly deviated from the technical parameters due to the difference in test methods.

MECHANICAL LOADING

Front Side Maximum Static Loading	5400Pa
Rear Side Maximum Static Loading	2400Pa
Hailstone Test	25mm Hailstone at the speed of 23m/s

TEMPERATURE RATINGS (STC)

Temperature Coefficient of Isc	+0.04%/°C
Temperature Coefficient of Voc	-0.23%/°C
Temperature Coefficient of Pmax	-0.28%/°C



430~450 Watt

HORAY

TIER1
BloombergNEF

HS **182-108** TC-D Ocean N-type Bifacial Modules

N-type
SMBB

SMBB Half-Cell Technology
More uniform current collection capability, reducing the current heat loss of the internal cells.

CONVERSION

Higher Output Power
The output power of 108 half-cells monocrystalline modules is up to 450W.

LOW LIGHT

Low Light Features
Higher performance under low light environment.

RESISTANT

Harsh Environmental Adaptability
Strict salt spray and ammonia corrosion test by the third party.

LID
LOW LID

N-type With Very Low LID
N-type solar cell has very low LID naturally which can reduce power degradation.

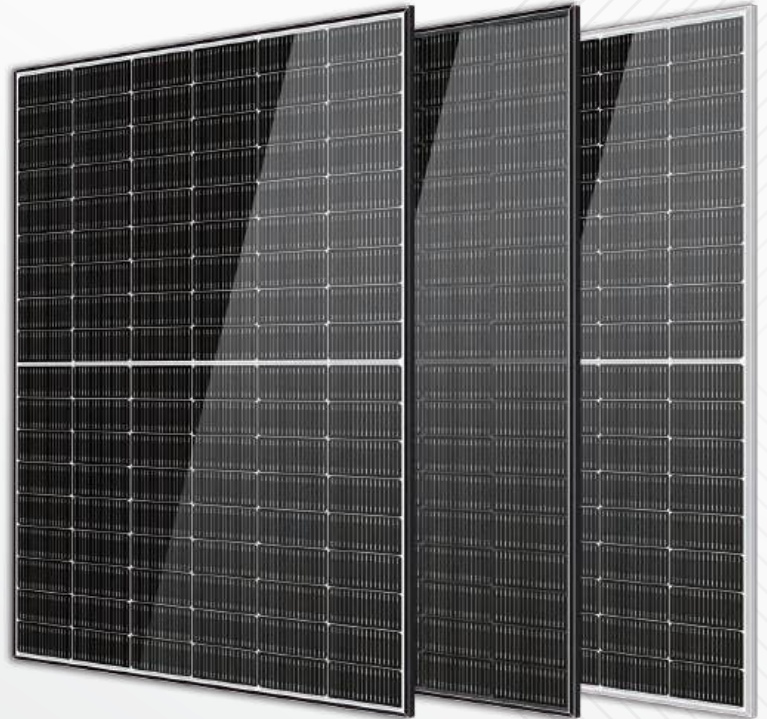

IEC61215:2021

IEC61730:2023

ISO9001:2015 Quality Management System

ISO14001:2015 Environmental Management System

ISO45001:2018 Occupational Health and Safety Management System

CE: Europe Standard

China Quality Certification Centre

Solar Product Certification

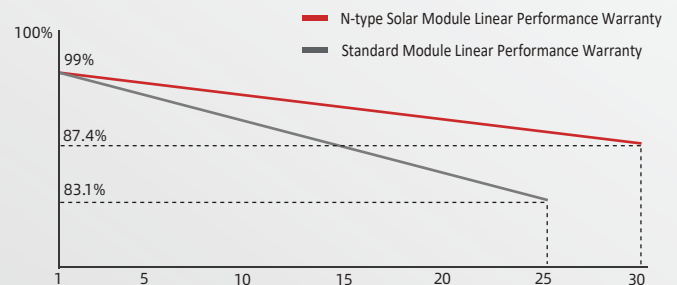
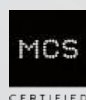

15

15-year product warranty

30

30-year linear power output warranty

HEADQUARTER: HORAY SOLAR CO., LTD.

GLOBAL MARKETING AND SERVICE: HORAY SOLAR GMBH

sales@horaysolar.com www.horaysolar.com +86-510 83580688
No.300 Huiming Road, Huishan District, 214177 Wuxi, Jiangsu, P.R. China

info@horaysolar.com www.horaysolar.com
Robert-Bosch-Straße 27-29, 63225 Langen, Germany

MECHANICAL DIAGRAMS

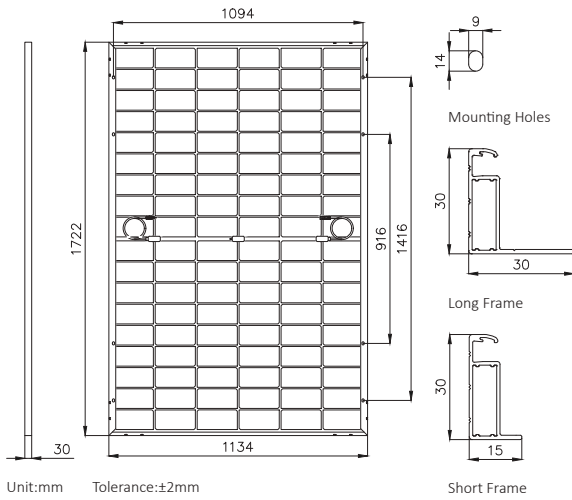

MECHANICAL PARAMETERS

Weight	24.0kg
Dimension	1722×1134×30mm
Cell Orientation	108 (6×18)
Junction Box	IP68, three diodes
Output Cable	4mm ² ,±1100mm (length can be customized)
Connector	MC4 compatible
Glass	2.0+2.0mm AR coated heat strengthened glass
Frame	Anodized aluminum alloy frame
Packaging	37pcs per pallet/962pcs per 40'HC

CURVES OF PV MODULE

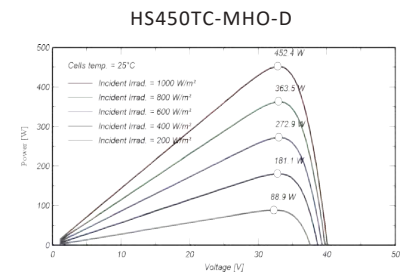
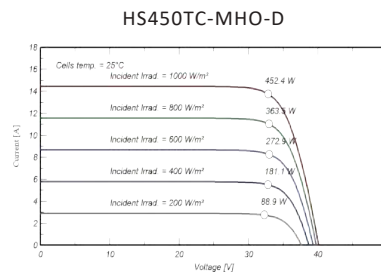

ELECTRICAL CHARACTERISTICS

Module Type	HS430TC-MHO-D		HS435TC-MHO-D		HS440TC-MHO-D		HS445TC-MHO-D		HS450TC-MHO-D	
	STC	NMOT	STC	NMOT	STC	NMOT	STC	NMOT	STC	NMOT
Maximum Power(Pmax/W)	430	328	435	332	440	336	445	340	450	344
Open Circuit Voltage(Voc/V)	39.30	37.10	39.50	37.30	39.70	37.50	39.90	37.70	40.10	37.90
Short Circuit Current(Isc/A)	14.15	11.43	14.22	11.49	14.30	11.55	14.37	11.61	14.45	11.67
Maximum Power Voltage(Vmp/V)	32.84	30.50	33.04	30.70	33.24	30.90	33.44	31.10	33.64	31.30
Maximum Power Current(Imp/A)	13.10	10.74	13.17	10.80	13.24	10.86	13.31	10.93	13.38	10.99
Module Efficiency(%)	22.0		22.3		22.5		22.8		23.0	

* Under Standard Test Conditions (STC) of irradiance of 1000 W/m², spectrum AM 1.5 and cell temperature of 25°C.

* Under Nominal Module Operating Temperature (NMOT), irradiance of 800 W/m², spectrum AM 1.5, ambient temperature 20°C, wind speed 1 m/s.

ELECTRICAL CHARACTERISTICS WITH 10% SOLAR IRRADIATION RATIO (BNPI)

Maximum Power(Pmax/W)	474	479	485	490	495
Open Circuit Voltage(Voc/V)	39.30	39.50	39.70	39.90	40.10
Short Circuit Current(Isc/A)	15.56	15.64	15.73	15.81	15.89
Maximum Power Voltage(Vmp/V)	32.84	33.04	33.24	33.44	33.64
Maximum Power Current(Imp/A)	14.43	14.50	14.59	14.65	14.71

*Rear side power gain:The additional gain from the rear side compared to the power of the front side at the standard test condition.It depends on mounting (structure,height,tilt angle etc.)and albedo of the ground.

OPERATING PARAMETERS

Operational Temperature	-40°C~+85°C
Power Output Tolerance	0~3%
Maximum System Voltage	1500V
Maximum Series Fuse Rating	25A
Nominal Operating Cell Temperature	45±2°C
Protection Class	Class II
Bifaciality	80±5%
Fire Rating	IEC Class A

*The actual test value may be slightly deviated from the technical parameters due to the difference in test methods.

MECHANICAL LOADING

Front Side Maximum Static Loading	5400Pa
Rear Side Maximum Static Loading	2400Pa
Hailstone Test	25mm Hailstone at the speed of 23m/s

TEMPERATURE RATINGS (STC)

Temperature Coefficient of Isc	+0.04%/°C
Temperature Coefficient of Voc	-0.23%/°C
Temperature Coefficient of Pmax	-0.28%/°C



480~500 Watt

HORAY

TIER1
BloombergNEF

HS **182-120** TC-D Ocean N-type Bifacial Modules

N-type
SMBB

SMBB Half-Cell Technology
More uniform current collection capability, reducing the current heat loss of the internal cells.

CONVERSION

Higher Output Power
The output power of 120 half-cells monocrystalline modules is up to 500W.

LOW LIGHT

Low Light Features
Higher performance under low light environment.

RESISTANT

Harsh Environmental Adaptability
Strict salt spray and ammonia corrosion test by the third party.

LID
LOW LID

N-type With Very Low LID
N-type solar cell has very low LID naturally which can reduce power degradation.

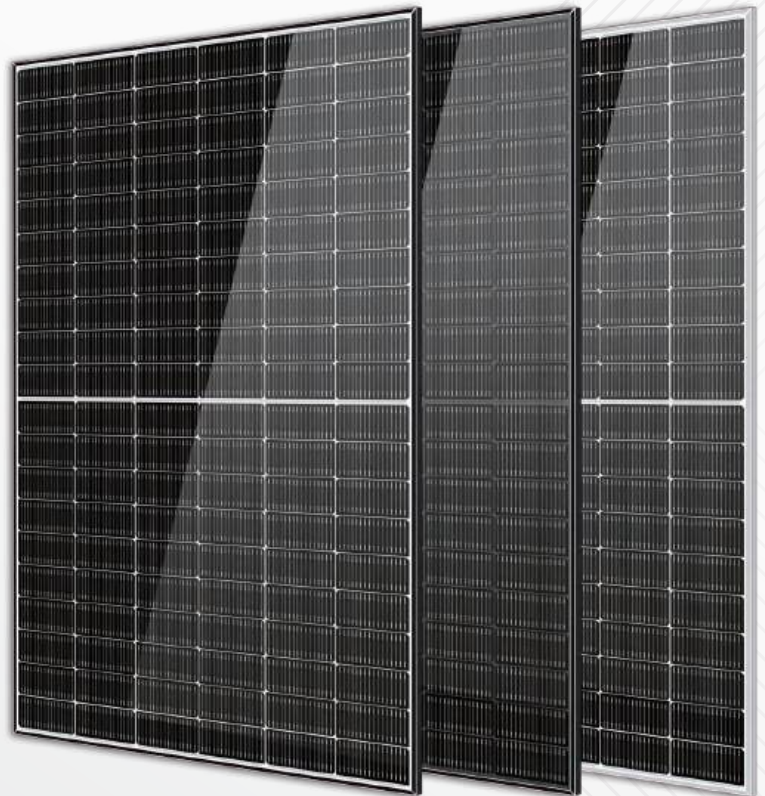

IEC61215:2021

IEC61730:2023

ISO9001:2015 Quality Management System

ISO14001:2015 Environmental Management System

ISO45001:2018 Occupational Health and Safety Management System

CE: Europe Standard

China Quality Certification Centre

Solar Product Certification

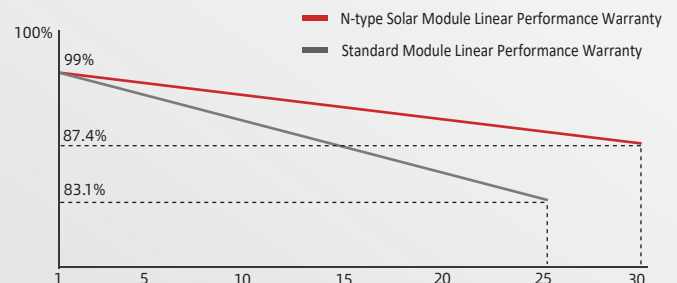
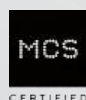

15-year product warranty



30-year linear power output warranty

HEADQUARTER: HORAY SOLAR CO., LTD.

GLOBAL MARKETING AND SERVICE: HORAY SOLAR GMBH

sales@horaysolar.com www.horaysolar.com +86-510 83580688
No.300 Huiming Road, Huishan District, 214177 Wuxi, Jiangsu, P.R. China

info@horaysolar.com www.horaysolar.com
Robert-Bosch-Straße 27-29, 63225 Langen, Germany

MECHANICAL DIAGRAMS

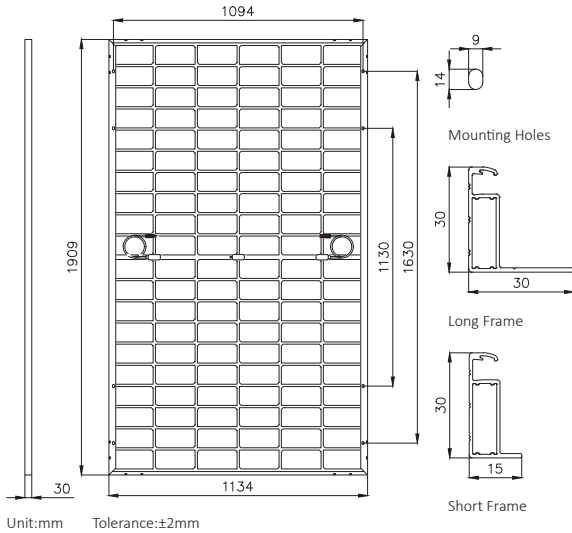

MECHANICAL PARAMETERS

Weight	25.5kg
Dimension	1909×1134×30mm
Cell Orientation	120 (6×20)
Junction Box	IP68, three diodes
Output Cable	4mm ² ,±300mm (length can be customized)
Connector	MC4 compatible
Glass	2.0+2.0mm AR coated heat strengthened glass
Frame	Anodized aluminum alloy frame
Packaging	37pcs per pallet/888pcs per 40'HC

CURVES OF PV MODULE

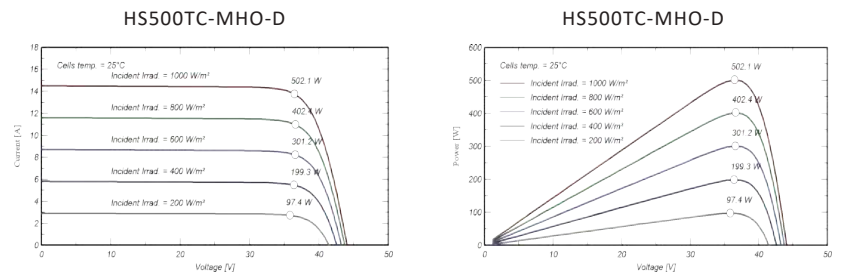

ELECTRICAL CHARACTERISTICS

Module Type	HS480TC-MHO-D		HS485TC-MHO-D		HS490TC-MHO-D		HS495TC-MHO-D		HS500TC-MHO-D	
	STC	NMOT	STC	NMOT	STC	NMOT	STC	NMOT	STC	NMOT
Maximum Power(Pmax/W)	480	365	485	369	490	374	495	378	500	382
Open Circuit Voltage(Voc/V)	43.26	41.00	43.46	41.20	43.66	41.40	43.86	41.60	44.06	41.80
Short Circuit Current(Isc/A)	14.22	11.49	14.30	11.55	14.37	11.61	14.43	11.66	14.50	11.72
Maximum Power Voltage(Vmp/V)	36.44	33.80	36.64	34.00	36.84	34.20	37.04	34.40	37.24	34.60
Maximum Power Current(Imp/A)	13.17	10.82	13.23	10.88	13.31	10.93	13.36	10.99	13.43	11.04
Module Efficiency(%)	22.2		22.4		22.6		22.9		23.1	

* Under Standard Test Conditions (STC) of irradiance of 1000 W/m², spectrum AM 1.5 and cell temperature of 25°C.

* Under Nominal Module Operating Temperature (NMOT), irradiance of 800 W/m², spectrum AM 1.5, ambient temperature 20°C, wind speed 1 m/s.

ELECTRICAL CHARACTERISTICS WITH 10% SOLAR IRRADIATION RATIO (BNPI)

Maximum Power(Pmax/W)	529	534	540	546	550
Open Circuit Voltage(Voc/V)	43.40	43.60	43.80	44.00	44.20
Short Circuit Current(Isc/A)	15.64	15.73	15.81	15.87	15.95
Maximum Power Voltage(Vmp/V)	36.44	36.64	36.84	37.04	37.24
Maximum Power Current(Imp/A)	14.52	14.57	14.66	14.74	14.77

*Rear side power gain:The additional gain from the rear side compared to the power of the front side at the standard test condition.It depends on mounting (structure,height,tilt angle etc.)and albedo of the ground.

OPERATING PARAMETERS

Operational Temperature	-40°C~+85°C
Power Output Tolerance	0~3%
Maximum System Voltage	1500V
Maximum Series Fuse Rating	25A
Nominal Operating Cell Temperature	45±2°C
Protection Class	Class II
Bifaciality	80±5%
Fire Rating	IEC Class A

*The actual test value may be slightly deviated from the technical parameters due to the difference in test methods.

MECHANICAL LOADING

Front Side Maximum Static Loading	5400Pa
Rear Side Maximum Static Loading	2400Pa
Hailstone Test	25mm Hailstone at the speed of 23m/s

TEMPERATURE RATINGS (STC)

Temperature Coefficient of Isc	+0.04%/°C
Temperature Coefficient of Voc	-0.23%/°C
Temperature Coefficient of Pmax	-0.28%/°C



YouTube



Facebook



LinkedIn



WeChat

530~550 Watt

HORAY | TIER1 BloombergNEF

HS 182-132 TC-D Ocean N-type Bifacial Modules



SMBB Half-Cell Technology

More uniform current collection capability, reducing the current heat loss of the internal cells.



Higher Output Power

The output power of 132 half-cells monocrystalline modules is up to 550W.



Low Light Features

Higher performance under low light environment.



Harsh Environmental Adaptability

Strict salt spray and ammonia corrosion test by the third party.



N-type With Very Low LID

N-type solar cell has very low LID naturally which can reduce power degradation.

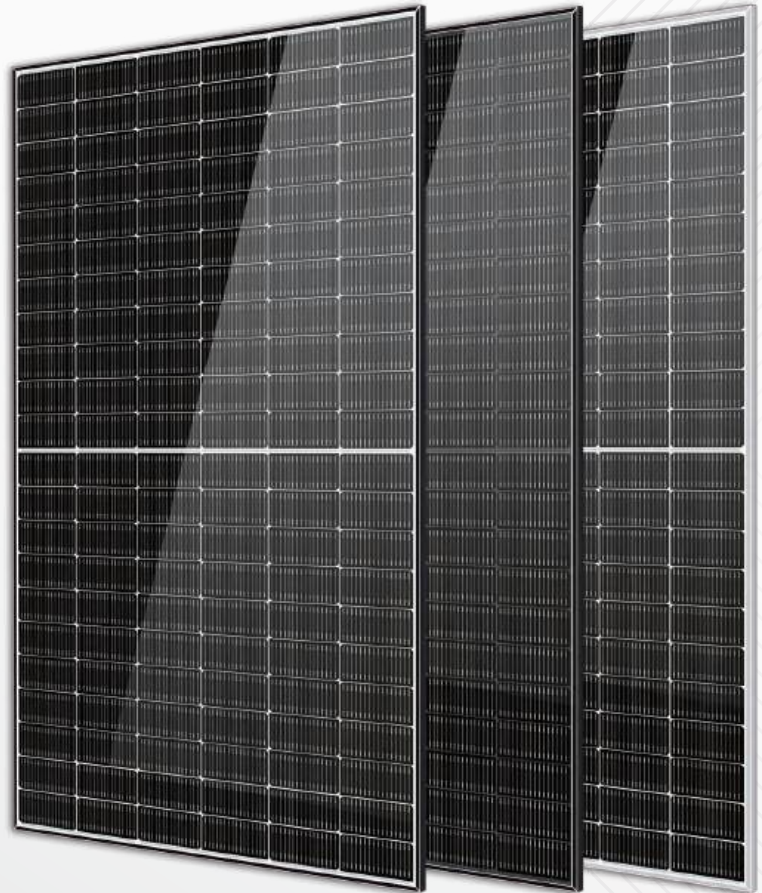

IEC61215:2021

IEC61730:2023

ISO9001:2015 Quality Management System

ISO14001:2015 Environmental Management System

ISO45001:2018 Occupational Health and Safety Management System

CE: Europe Standard

China Quality Certification Centre

Solar Product Certification

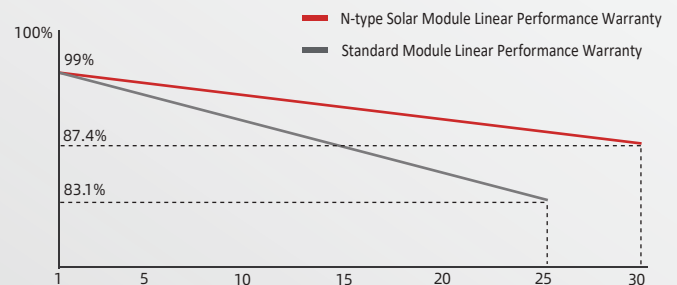
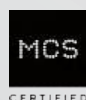

15-year product warranty



30-year linear power output warranty

HEADQUARTER: HORAY SOLAR CO., LTD.

GLOBAL MARKETING AND SERVICE: HORAY SOLAR GMBH

sales@horaysolar.com www.horaysolar.com +86-510 83580688

info@horaysolar.com www.horaysolar.com

No.300 Huiming Road, Huishan District, 214177 Wuxi, Jiangsu, P.R. China

Robert-Bosch-Straße 27-29, 63225 Langen, Germany

MECHANICAL DIAGRAMS

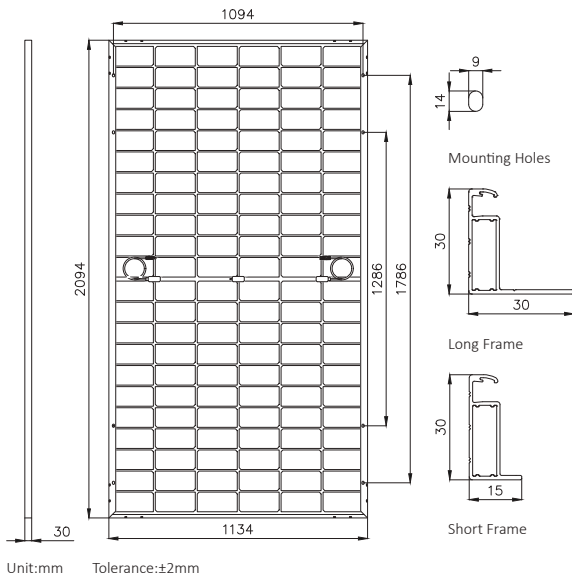

MECHANICAL PARAMETERS

Weight	29.0kg
Dimension	2094×1134×30mm
Cell Orientation	132 (6×22)
Junction Box	IP68, three diodes
Output Cable	4mm ² ,±300mm (length can be customized)
Connector	MC4 compatible
Glass	2.0+2.0mm AR coated heat strengthened glass
Frame	Anodized aluminum alloy frame
Packaging	37pcs per pallet/814pcs per 40'HC

CURVES OF PV MODULE

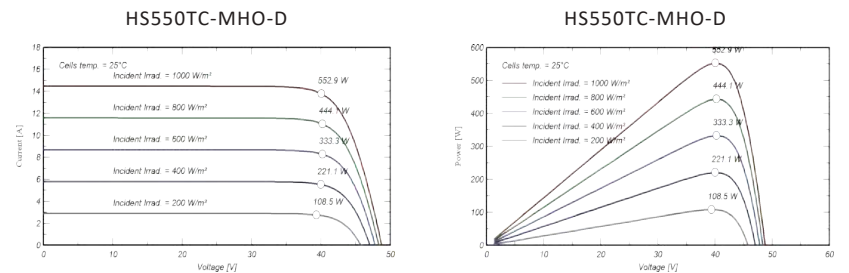

ELECTRICAL CHARACTERISTICS

Module Type	HS530TC-MHO-D		HS535TC-MHO-D		HS540TC-MHO-D		HS545TC-MHO-D		HS550TC-MHO-D	
	STC	NMOT	STC	NMOT	STC	NMOT	STC	NMOT	STC	NMOT
Maximum Power(Pmax/W)	530	401	535	408	540	412	545	416	550	420
Open Circuit Voltage(Voc/V)	47.81	45.20	48.04	45.50	48.27	45.80	48.52	46.00	48.76	46.30
Short Circuit Current(Isc/A)	14.22	11.49	14.29	11.54	14.35	11.59	14.41	11.64	14.47	11.69
Maximum Power Voltage(Vmp/V)	40.24	37.30	40.44	37.60	40.64	37.70	40.84	37.90	41.04	38.10
Maximum Power Current(Imp/A)	13.17	10.81	13.23	10.86	13.29	10.92	13.34	10.98	13.40	11.02
Module Efficiency(%)	22.3		22.5		22.7		23.0		23.2	

* Under Standard Test Conditions (STC) of irradiance of 1000 W/m², spectrum AM 1.5 and cell temperature of 25°C.

* Under Nominal Module Operating Temperature (NMOT), irradiance of 800 W/m², spectrum AM 1.5, ambient temperature 20°C, wind speed 1 m/s.

ELECTRICAL CHARACTERISTICS WITH 10% SOLAR IRRADIATION RATIO (BNPI)

Maximum Power(Pmax/W)	584	589	595	600	605
Open Circuit Voltage(Voc/V)	48.00	48.20	48.40	48.60	48.80
Short Circuit Current(Isc/A)	15.64	15.72	15.78	15.85	15.92
Maximum Power Voltage(Vmp/V)	40.24	40.44	40.64	40.84	41.04
Maximum Power Current(Imp/A)	14.51	14.56	14.64	14.69	14.74

*Rear side power gain:The additional gain from the rear side compared to the power of the front side at the standard test condition.It depends on mounting (structure,height,tilt angle etc.)and albedo of the ground.

OPERATING PARAMETERS

Operational Temperature	-40°C~+85°C
Power Output Tolerance	0~3%
Maximum System Voltage	1500V
Maximum Series Fuse Rating	25A
Nominal Operating Cell Temperature	45±2°C
Protection Class	Class II
Bifaciality	80±5%
Fire Rating	IEC Class A

*The actual test value may be slightly deviated from the technical parameters due to the difference in test methods.

MECHANICAL LOADING

Front Side Maximum Static Loading	5400Pa
Rear Side Maximum Static Loading	2400Pa
Hailstone Test	25mm Hailstone at the speed of 23m/s

TEMPERATURE RATINGS (STC)

Temperature Coefficient of Isc	+0.04%/°C
Temperature Coefficient of Voc	-0.23%/°C
Temperature Coefficient of Pmax	-0.28%/°C



585~605 Watt

HORAY

TIER1
BloombergNEF

HS **182-144** TC-D Ocean N-type Bifacial Modules



SMBB Half-Cell Technology

More uniform current collection capability, reducing the current heat loss of the internal cells.



Higher Output Power

The output power of 144 half-cells monocrystalline modules is up to 605W.



Low Light Features

Higher performance under low light environment.



Harsh Environmental Adaptability

Strict salt spray and ammonia corrosion test by the third party.



N-type With Very Low LID

N-type solar cell has very low LID naturally which can reduce power degradation.

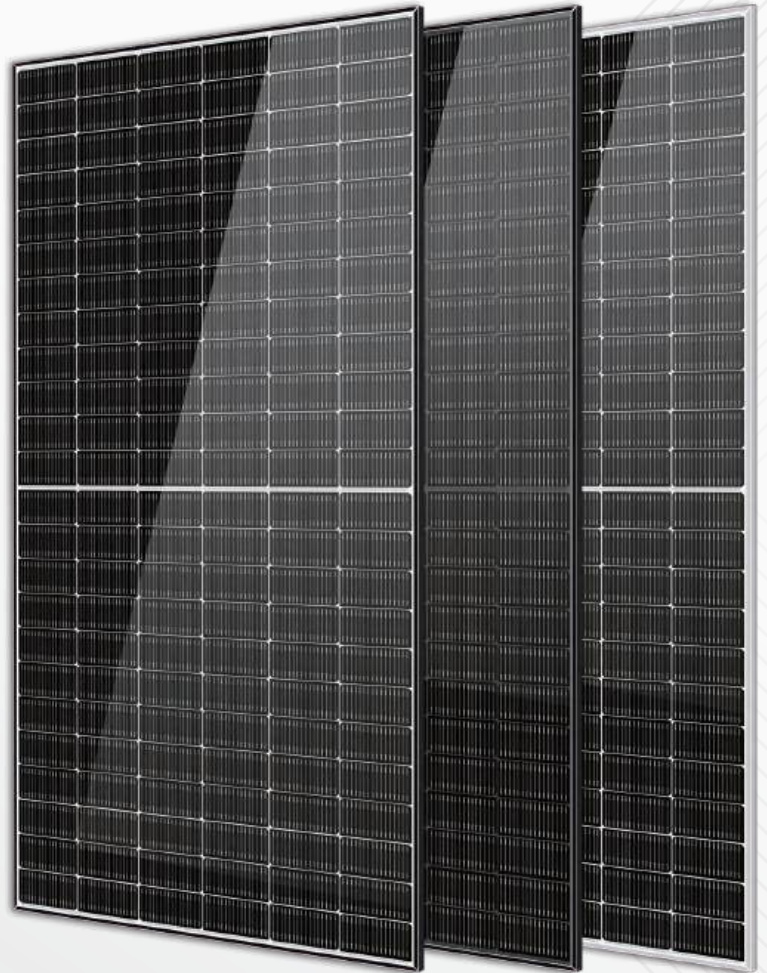

IEC61215:2021

IEC61730:2023

ISO9001:2015 Quality Management System

ISO14001:2015 Environmental Management System

ISO45001:2018 Occupational Health and Safety Management System

CE: Europe Standard

China Quality Certification Centre

Solar Product Certification

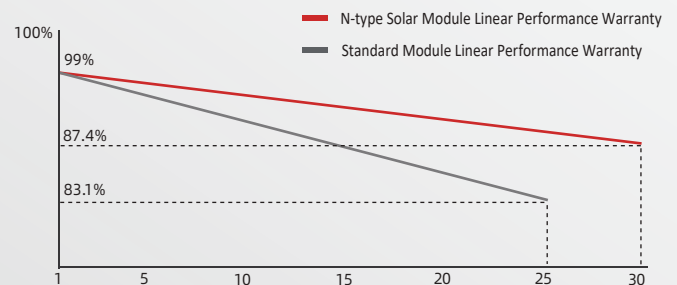
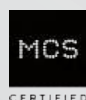

15-year product warranty



30-year linear power output warranty

HEADQUARTER: HORAY SOLAR CO., LTD.

GLOBAL MARKETING AND SERVICE: HORAY SOLAR GMBH

sales@horaysolar.com www.horaysolar.com +86-510 83580688

info@horaysolar.com www.horaysolar.com

No.300 Huiming Road, Huishan District, 214177 Wuxi, Jiangsu, P.R. China

Robert-Bosch-Straße 27-29, 63225 Langen, Germany

MECHANICAL DIAGRAMS

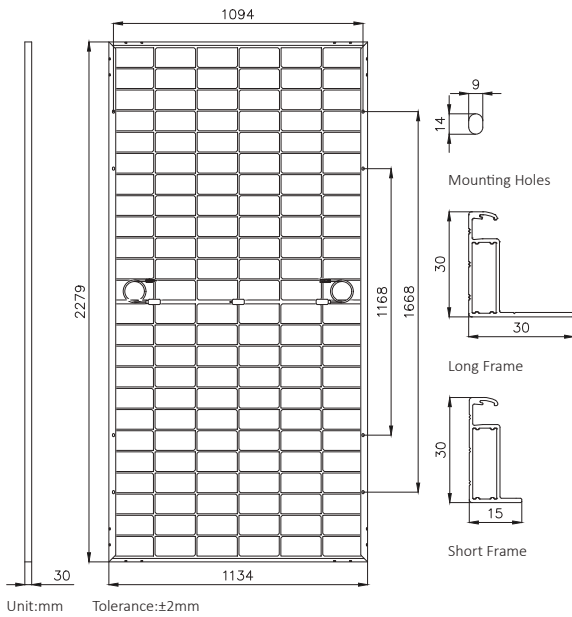

MECHANICAL PARAMETERS

Weight	31.5kg
Dimension	2279×1134×30mm
Cell Orientation	144 (6×24)
Junction Box	IP68, three diodes
Output Cable	4mm ² ,±300mm (length can be customized)
Connector	MC4 compatible
Glass	2.0+2.0mm AR coated heat strengthened glass
Frame	Anodized aluminum alloy frame
Packaging	37pcs per pallet/740pcs per 40'HC

CURVES OF PV MODULE

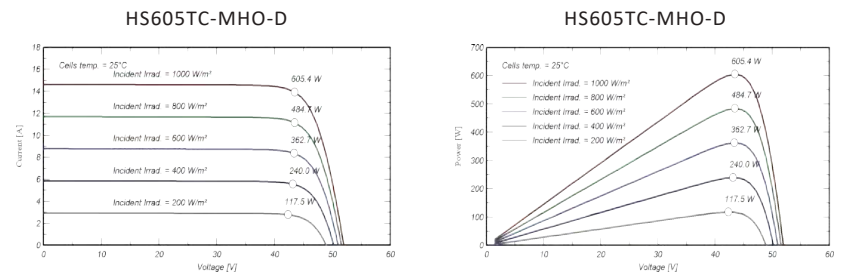

ELECTRICAL CHARACTERISTICS

Module Type	HS585TC-MHO-D		HS590TC-MHO-D		HS595TC-MHO-D		HS600TC-MHO-D		HS605TC-MHO-D	
	STC	NMOT	STC	NMOT	STC	NMOT	STC	NMOT	STC	NMOT
Maximum Power(Pmax/W)	585	444	590	448	595	451	600	455	605	459
Open Circuit Voltage(Voc/V)	51.52	48.70	51.63	48.90	51.74	49.00	51.85	49.10	51.95	49.20
Short Circuit Current(Isc/A)	14.30	11.55	14.38	11.62	14.46	11.68	14.54	11.74	14.62	11.81
Maximum Power Voltage(Vmp/V)	43.33	40.50	43.44	40.70	43.55	40.80	43.66	40.90	43.76	41.00
Maximum Power Current(Imp/A)	13.51	10.94	13.59	11.00	13.66	11.05	13.74	11.12	13.83	11.20
Module Efficiency(%)	22.6		22.8		23.0		23.2		23.4	

* Under Standard Test Conditions (STC) of irradiance of 1000 W/m², spectrum AM 1.5 and cell temperature of 25°C.

* Under Nominal Module Operating Temperature (NMOT), irradiance of 800 W/m², spectrum AM 1.5, ambient temperature 20°C, wind speed 1 m/s.

ELECTRICAL CHARACTERISTICS WITH 10% SOLAR IRRADIATION RATIO (BNPI)

Maximum Power(Pmax/W)	638	644	649	654	660
Open Circuit Voltage(Voc/V)	51.60	51.70	51.80	51.90	52.00
Short Circuit Current(Isc/A)	15.64	15.73	15.82	15.91	16.00
Maximum Power Voltage(Vmp/V)	43.33	43.44	43.55	43.66	43.76
Maximum Power Current(Imp/A)	14.72	14.83	14.90	14.98	15.08

*Rear side power gain:The additional gain from the rear side compared to the power of the front side at the standard test condition.It depends on mounting (structure,height,tilt angle etc.)and albedo of the ground.

OPERATING PARAMETERS

Operational Temperature	-40°C~+85°C
Power Output Tolerance	0~3%
Maximum System Voltage	1500V
Maximum Series Fuse Rating	25A
Nominal Operating Cell Temperature	45±2°C
Protection Class	Class II
Bifaciality	80±5%
Fire Rating	IEC Class A

*The actual test value may be slightly deviated from the technical parameters due to the difference in test methods.

MECHANICAL LOADING

Front Side Maximum Static Loading	5400Pa
Rear Side Maximum Static Loading	2400Pa
Hailstone Test	25mm Hailstone at the speed of 23m/s

TEMPERATURE RATINGS (STC)

Temperature Coefficient of Isc	+0.04%/°C
Temperature Coefficient of Voc	-0.23%/°C
Temperature Coefficient of Pmax	-0.28%/°C



590W

HORAY



HS 182-144 TC-D Ocean N-type Bifacial Modules

N-type SMBB **SMBB Half-Cell Technology**
 More uniform current collection capability, reducing the current heat loss of the internal cells.

CONVERSION **Higher Output Power**
 The output power of 144 half-cells monocrystalline modules is up to 590W.

LOW LIGHT **Low Light Features**
 Higher performance under low light environment.

RESISTANT **Harsh Environmental Adaptability**
 Strict salt spray and ammonia corrosion test by the third party.

LOW LID **N-type With Very Low LID**
 N-type solar cell has very low LID naturally which can reduce power degradation.

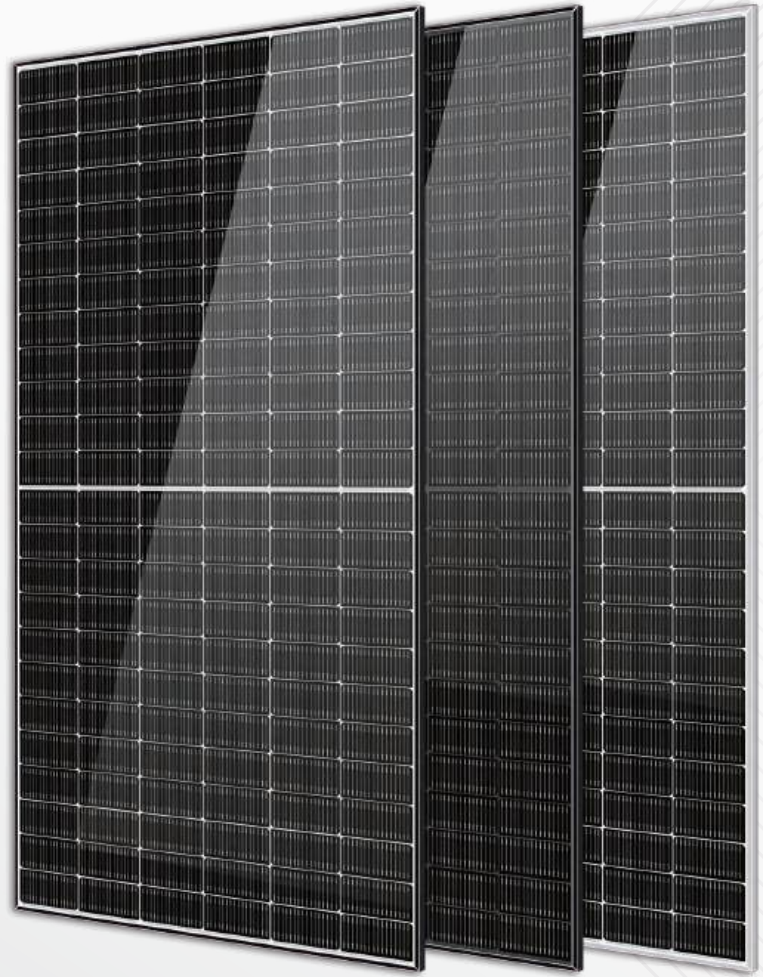

- IEC61215:2021
- IEC61730:2023
- ISO9001:2015 Quality Management System
- ISO14001:2015 Environmental Management System
- ISO45001:2018 Occupational Health and Safety Management System
- CE: Europe Standard
- China Quality Certification Centre
- Solar Product Certification

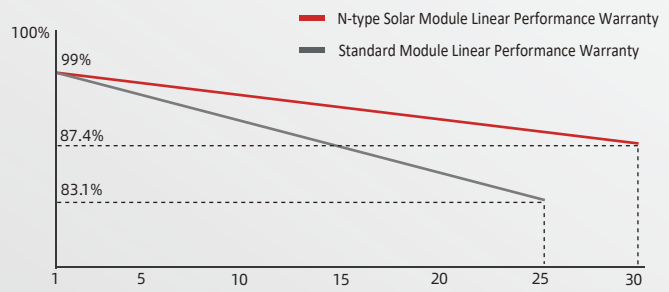

15 15-year product warranty

30 30-year linear power output warranty

HEADQUARTER: HORAY SOLAR CO., LTD. GLOBAL MARKETING AND SERVICE: HORAY SOLAR GMBH

sales@horaysolar.com www.horaysolar.com +86-510 83580688
 No.300 Huiming Road, Huishan District, 214177 Wuxi, Jiangsu, P.R. China

info@horaysolar.com www.horaysolar.com
 Robert-Bosch-Straße 27-29, 63225 Langen, Germany

MECHANICAL DIAGRAMS

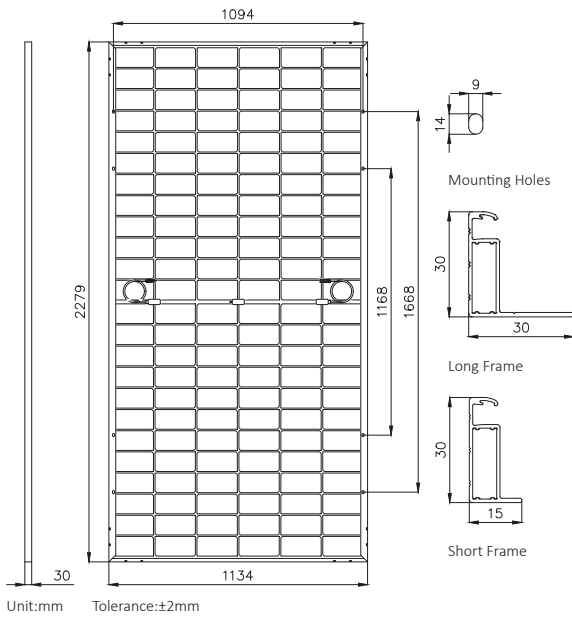

MECHANICAL PARAMETERS

Weight	31.5kg
Dimension	2279×1134×30mm
Cell Orientation	144 (6×24)
Junction Box	IP68, three diodes
Output Cable	4mm ² ,±300mm (length can be customized)
Connector	MC4 compatible
Glass	2.0+2.0mm AR coated heat strengthened glass
Frame	Anodized aluminum alloy frame
Packaging	37pcs per pallet/740pcs per 40'HC

CURVES OF PV MODULE

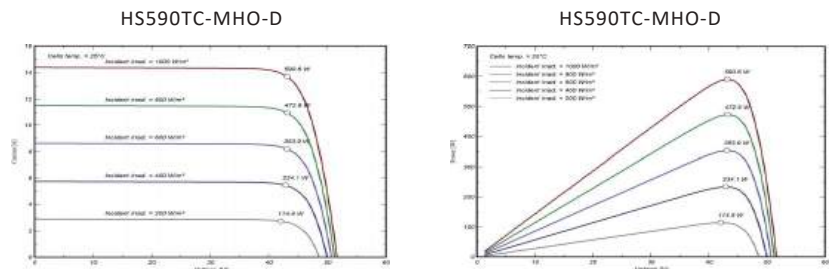

ELECTRICAL CHARACTERISTICS

Module Type	HS570TC-MHO-D		HS575TC-MHO-D		HS580TC-MHO-D		HS585TC-MHO-D		HS590TC-MHO-D	
	STC	NMOT	STC	NMOT	STC	NMOT	STC	NMOT	STC	NMOT
Maximum Power(Pmax/W)	570	432	575	436	580	439	585	444	590	448
Open Circuit Voltage(Voc/V)	51.19	48.41	51.30	48.52	51.41	48.62	51.52	48.73	51.63	48.94
Short Circuit Current(Isc/A)	14.05	11.35	14.14	11.43	14.22	11.49	14.30	11.55	14.38	11.62
Maximum Power Voltage(Vmp/V)	43.00	40.21	43.11	40.31	43.22	40.42	43.33	40.53	43.44	40.72
Maximum Power Current(Imp/A)	13.26	10.74	13.34	10.81	13.42	10.87	13.51	10.94	13.59	11.01
Module Efficiency(%)	22.1		22.3		22.5		22.6		22.8	

* Under Standard Test Conditions (STC) of irradiance of 1000 W/m², spectrum AM 1.5 and cell temperature of 25°C.

* Under Nominal Module Operating Temperature (NMOT), irradiance of 800 W/m², spectrum AM 1.5, ambient temperature 20°C, wind speed 1 m/s.

ELECTRICAL CHARACTERISTICS WITH 10% SOLAR IRRADIATION RATIO (BNPI)

Maximum Power(Pmax/W)	621	627	632	637	644
Open Circuit Voltage(Voc/V)	51.31	51.40	51.50	51.60	51.70
Short Circuit Current(Isc/A)	15.37	15.45	15.55	15.64	15.73
Maximum Power Voltage(Vmp/V)	42.41	42.60	42.70	42.80	42.90
Maximum Power Current(Imp/A)	14.63	14.72	14.81	14.90	15.00

*Rear side power gain:The additional gain from the rear side compared to the power of the front side at the standard test condition.It depends on mounting (structure,height,tilt angle etc.)and albedo of the ground.

OPERATING PARAMETERS

Operational Temperature	-40°C~+85°C
Power Output Tolerance	0~3%
Maximum System Voltage	1500V
Maximum Series Fuse Rating	25A
Nominal Operating Cell Temperature	45±2°C
Protection Class	Class II
Bifaciality	80±5%
Fire Rating	IEC Class A

*The actual test value may be slightly deviated from the technical parameters due to the difference in test methods.

MECHANICAL LOADING

Front Side Maximum Static Loading	5400Pa
Rear Side Maximum Static Loading	2400Pa
Hailstone Test	25mm Hailstone at the speed of 23m/s

TEMPERATURE RATINGS (STC)

Temperature Coefficient of Isc	+0.04%/°C
Temperature Coefficient of Voc	-0.23%/°C
Temperature Coefficient of Pmax	-0.28%/°C



Solar Ocean

570–590 Watt N-Type MONO-BIFACIAL MODULE

- IEC61215: 2021
IEC61730: 2023
TUV Rheinland Standard
- Lloyd'S Ariel Re
Solar Performance Insurance
- ISO9001: 2015
Quality Management System
- ISO14001:
Environmental Management System
- CE: Europe Standard
- Inmetro Certificate
- Japan JP-AC
- China Quality Certification Centre
Solar product certification

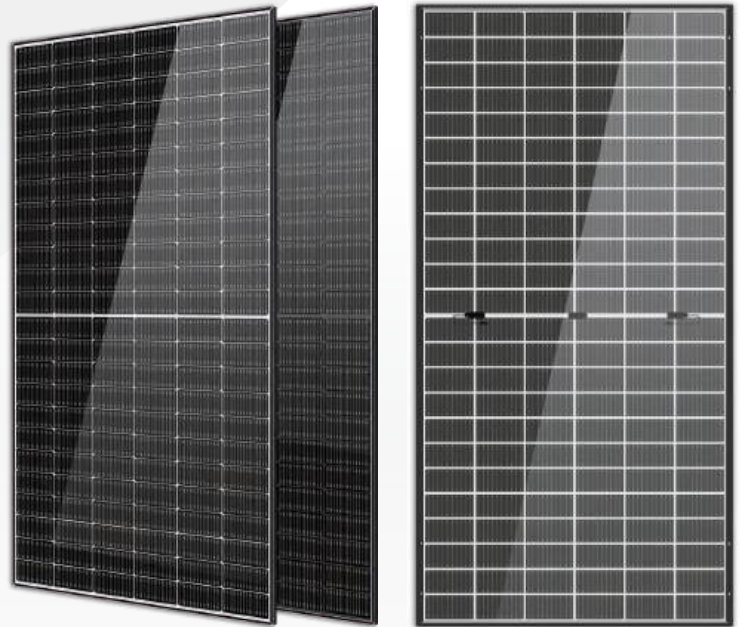

KEY FEATURES



SMBB Cell
More uniform current collection capability, reducing the current heat loss of the internal cells.



Low Light Features
Higher performance under low light environment.



Higher Output Power
The output power of 144 half-cells Monocrystalline modules is up to 590W.



LID Free
N-type solar cell has no LID naturally which can increase power generation.



Harsh Environmental Adaptability
Strict salt spray and ammonia corrosion test by the third party.



Load Capacity
Mechanical load tests including wind load 2400 Pa and snow load 5400 Pa.

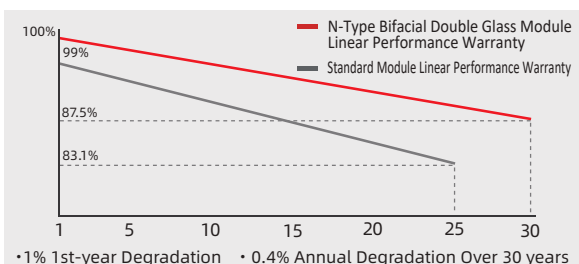

HEADQUARTER: HORAY SOLAR CO., LTD.

GLOBAL MARKETING AND SERVICE: HORAY SOLAR GMBH

✉ sales@horaysolar.com 🌐 www.horaysolar.com ☎ +86-510 83580688
📍 NO.30-5, East Yanxin Road, Huishan District, Wuxi 214177 Jiangsu P.R China

✉ info@horaysolar.com 🌐 www.horaysolar.com
📍 Robert-Bosch-Str. 27-29, 63225 Langen, Germany

❖ SPECIFICATIONS

Weight	31.5kg
Dimension	2279mm*1134mm*30mm
Cell Dimension	182*91mm
Cell Amount	72*2 pcs
Maximum System Voltage	1500V
Junction Box	IP68
Type of the front glass	2.0mm Coated ultra clear glass
Type of the back glass	2.0mm Heat-strengthened glass
Frame	Aluminum Alloy
Cable	4mm ² ,+300,-300mm/±1300mm Length can be customized
Connector	MC4 compatible
Application Level	Class A

❖ ELECTRICAL PARAMETERS AT STC

Module Type	HS570TC-MHO-D	HS575TC-MHO-D	HS580TC-MHO-D	HS585TC-MHO-D	HS590TC-MHO-D
Power	570W	575W	580W	585W	590W
Open Circuit Voltage	51.19V	51.30V	51.41V	51.52V	51.63V
Short Circuit Current	14.05A	14.14A	14.22A	14.30A	14.38A
Maximum Power Voltage	43.01V	43.11V	43.22V	43.33V	43.44V
Maximum Power Current	13.26A	13.34A	13.42A	13.51A	13.59A
Module Efficiency	22.06%	22.25%	22.50%	22.60%	22.80%

* Under Standard Test Conditions (STC) of irradiance of 1000 W/m², spectrum AM 1.5 and cell temperature of 25°C.

❖ ELECTRICAL PARAMETERS AT BNPI

Power	621W	627W	632W	637W	644W
Open Circuit Voltage	51.31V	51.42V	51.53V	51.64V	51.74V
Short Circuit Current	15.37A	15.45A	15.55A	15.64A	15.73A
Maximum Power Voltage	42.41V	42.63V	42.72V	42.84V	42.95V
Maximum Power Current	14.63A	14.72A	14.81A	14.9A	15A

*Rear side power gain:The additional gain from the rear side compared to the power of the front side at the standard test condition.It depends on mounting (structure,height,tilt angle etc.)and albedo of the ground.

❖ ELECTRICAL PARAMETERS AT NMOT

Power	432W	436W	439W	444W	448W
Open Circuit Voltage	48.41V	48.52V	48.62V	48.73V	48.94V
Short Circuit Current	11.35A	11.43A	11.49A	11.55A	11.62A
Maximum Power Voltage	40.21V	40.31V	40.42V	40.53V	40.72V
Maximum Power Current	10.74A	10.81A	10.87A	10.94A	11.01A

* Under Nominal Module Operating Temperature (NMOT), irradiance of 800 W/m², spectrum AM 1.5, ambient temperature 20°C, wind speed 1 m/s.

❖ TEMPERATURE CHARACTERISTICS

NMOT	45±2°C
Temp Coefficient of ISC	+0.04%/°C
Temp Coefficient of VOC	-0.23%/°C
Temp Coefficient of Pmax	-0.28%/°C

❖ PACKING CONFIGURATION

Modules/Pallet	37 Pieces
Packaging Description	20 Pallets, Total=(37+37)x10=740 Pieces
Modules/40' Container	740 Pieces

❖ MECHANICAL DIAGRAMS

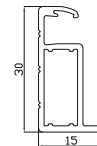
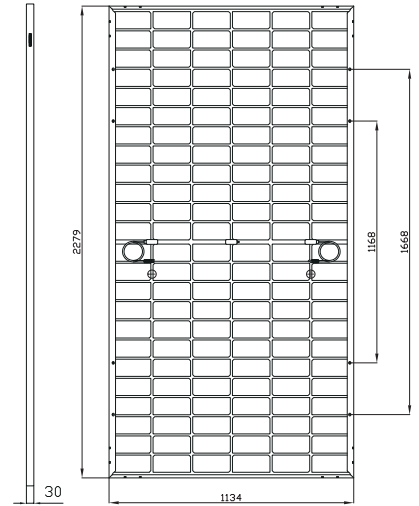

Section diagram of short frame profile

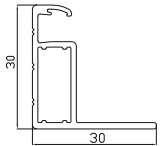

Section diagram of long frame profile

❖ IV CHARACTERISTICS

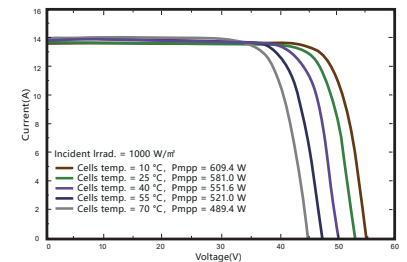
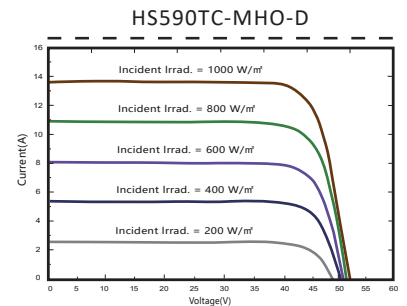

❖ MAXIMUM RATING

Power selection	0~+5W
Measuring uncertainty of Pm	±3%
Operating Temperature	-40°C~+85°C
Wind Load/Snow Load	2400pa/5400pa
Fuse Current	25A

15
YEARS

Quality
Warranty

30
YEARS

Power
Warranty

CAUTION: READ SAFETY AND INSTALLATION INSTRUCTIONS BEFORE USING THE PRODUCT.

©2024 Horay Solar Co.,Ltd. All rights reserved. Specifications included in this datasheet are subject to change without notice.

Version number: TC_MHO_D_EN_2024_A

455W

HORAY



HS 186R-108 TC Alpine N-type Mono-facial Modules



SMBB Half-Cell Technology

More uniform current collection capability, reducing the current heat loss of the internal cells.



Higher Output Power

The output power of 108 half-cells monocrystalline modules is up to 455W.



Low Light Features

Higher performance under low light environment.



Harsh Environmental Adaptability

Strict salt spray and ammonia corrosion test by the third party.



N-type With Very Low LID

N-type solar cell has very low LID naturally which can reduce power degradation.

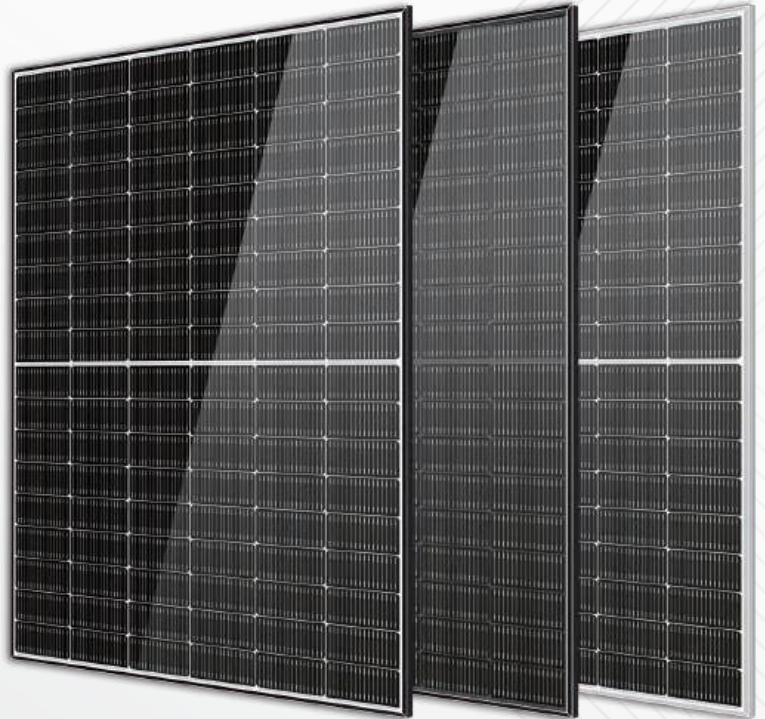

IEC61215:2021

IEC61730:2023

ISO9001:2015 Quality Management System

ISO14001:2015 Environmental Management System

IOS45001:2018 Occupational Health and Safety Management System

CE: Europe Standard

China Quality Certification Centre

Solar Product Certification

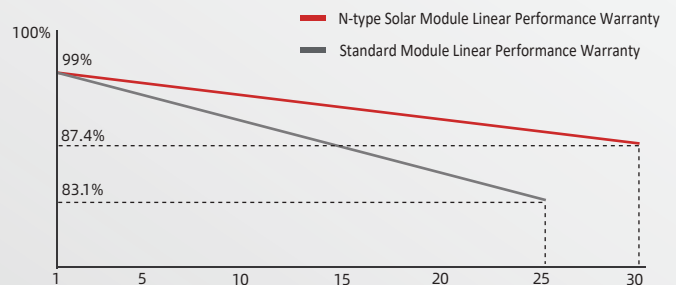
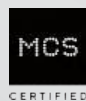

12-year product warranty



30-year linear power output warranty

HEADQUARTER: HORAY SOLAR CO., LTD.

GLOBAL MARKETING AND SERVICE: HORAY SOLAR GMBH

sales@horaysolar.com www.horaysolar.com +86-510 83580688
No.300 Huiming Road, Huishan District, 214177 Wuxi, Jiangsu, P.R. China

info@horaysolar.com www.horaysolar.com
Robert-Bosch-Straße 27-29, 63225 Langen, Germany

MECHANICAL DIAGRAMS

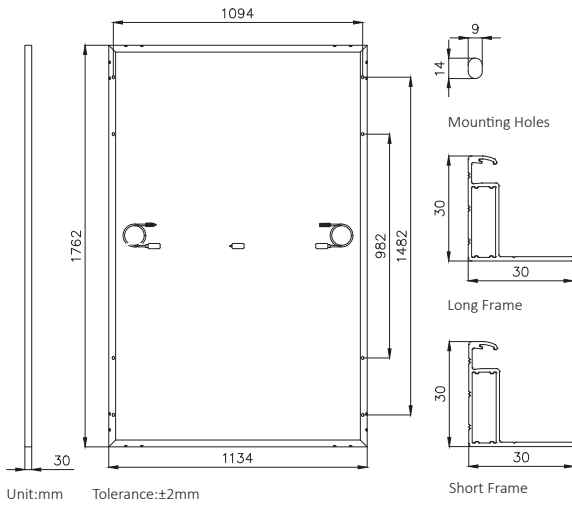

MECHANICAL PARAMETERS

Weight	20.5kg
Dimension	1762×1134×30mm
Cell Orientation	108 (6×18)
Junction Box	IP68, three diodes
Output Cable	4mm ² ,±300mm (length can be customized)
Connector	MC4 compatible
Glass	3.2mm AR coated heat strengthened glass
Frame	Anodized aluminum alloy frame
Packaging	37pcs per pallet/962pcs per 40'HC

MECHANICAL PARAMETERS

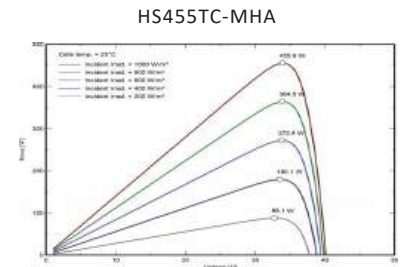
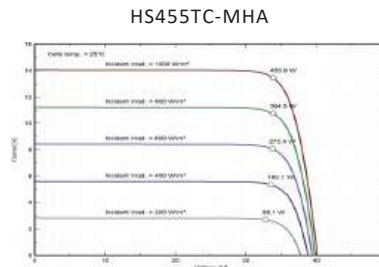

ELECTRICAL CHARACTERISTICS AT STC

Module Type	HS435TC-MHA	HS440TC-MHA	HS445TC-MHA	HS450TC-MHA	HS455TC-MHA
Testing Condition	STC	STC	STC	STC	STC
Maximum Power(Pmax/W)	435	440	445	450	455
Open Circuit Voltage(Voc/V)	39.36	39.57	39.77	39.97	40.14
Short Circuit Current(Isc/A)	13.72	13.80	13.87	13.94	14.03
Maximum Power Voltage(Vmp/V)	32.78	32.99	33.19	33.39	33.53
Maximum Power Current(Imp/A)	13.27	13.34	13.41	13.48	13.57
Module Efficiency(%)	21.8	22.0	22.3	22.5	22.8

* Under Standard Test Conditions (STC) of irradiance of 1000 W/m², spectrum AM 1.5 and cell temperature of 25°C.

ELECTRICAL CHARACTERISTICS AT NMOT

Module Type	HS435TC-MHA	HS440TC-MHA	HS445TC-MHA	HS450TC-MHA	HS455TC-MHA
Testing Condition	NMOT	NMOT	NMOT	NMOT	NMOT
Maximum Power(Pmax/W)	331	335	339	343	347
Open Circuit Voltage(Voc/V)	39.36	39.57	39.77	39.97	40.14
Short Circuit Current(Isc/A)	10.45	10.52	10.57	10.62	10.69
Maximum Power Voltage(Vmp/V)	32.78	32.99	33.19	33.39	33.53
Maximum Power Current(Imp/A)	10.11	10.17	10.22	10.27	10.34

* Under Nominal Module Operating Temperature (NMOT), irradiance of 800 W/m², spectrum AM 1.5, ambient temperature 20°C, wind speed 1 m/s.

OPERATING PARAMETERS

Operational Temperature	-40°C~+85°C
Power Output Tolerance	0~3%
Maximum System Voltage	1500V
Maximum Series Fuse Rating	25A
Nominal Operating Cell Temperature	45±2°C
Protection Class	Class II
Fire Rating	IEC Class C

*The actual test value may be slightly deviated from the technical parameters due to the difference in test methods.

MECHANICAL LOADING

Front Side Maximum Static Loading	5400Pa
Rear Side Maximum Static Loading	2400Pa
Hailstone Test	25mm Hailstone at the speed of 23m/s

TEMPERATURE RATINGS (STC)

Temperature Coefficient of Isc	+0.04%/°C
Temperature Coefficient of Voc	-0.23%/°C
Temperature Coefficient of Pmax	-0.28%/°C



510W

HORAY

TIER1
BloombergNEF

HS 186R-120 TC Alpine N-type Mono-facial Modules

N-type
SMBB

SMBB Half-Cell Technology
More uniform current collection capability, reducing the current heat loss of the internal cells.

CONVERSION

Higher Output Power
The output power of 120 half-cells monocrystalline modules is up to 510W.

LOW LIGHT

Low Light Features
Higher performance under low light environment.

RESISTANT

Harsh Environmental Adaptability
Strict salt spray and ammonia corrosion test by the third party.

LID
LOW LID

N-type With Very Low LID
N-type solar cell has very low LID naturally which can reduce power degradation.

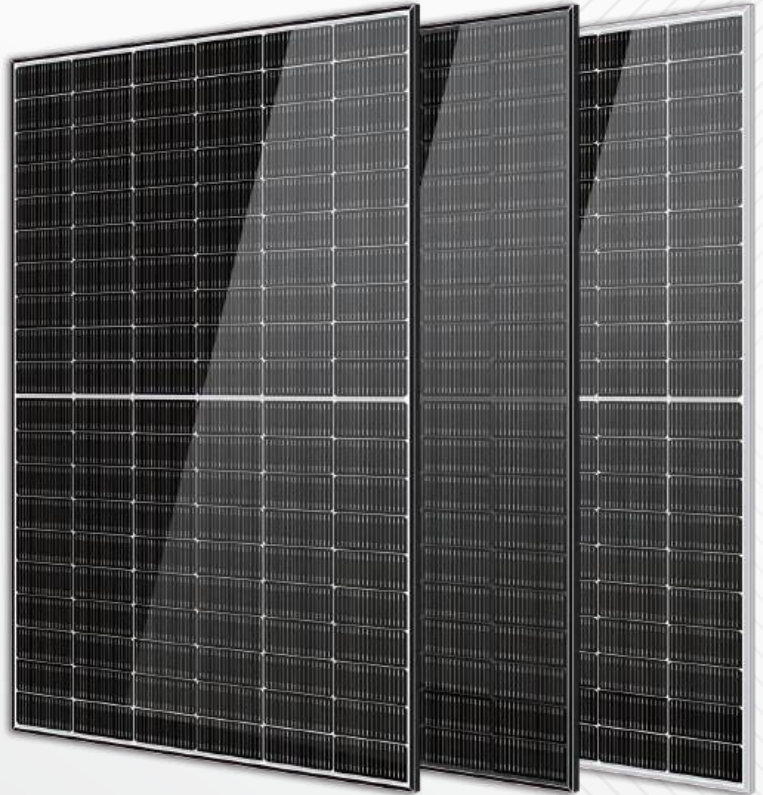

IEC61215:2021

IEC61730:2023

ISO9001:2015 Quality Management System

ISO14001:2015 Environmental Management System

IOS45001:2018 Occupational Health and Safety Management System

CE: Europe Standard

China Quality Certification Centre

Solar Product Certification

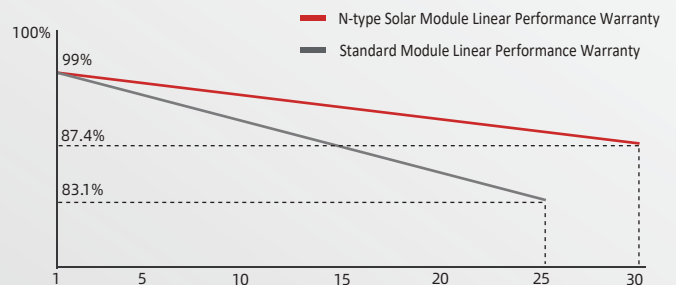
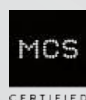

12

12-year product warranty

30

30-year linear power output warranty

HEADQUARTER: HORAY SOLAR CO., LTD.

GLOBAL MARKETING AND SERVICE: HORAY SOLAR GMBH

sales@horaysolar.com www.horaysolar.com +86-510 83580688

info@horaysolar.com www.horaysolar.com

No.300 Huiming Road, Huishan District, 214177 Wuxi, Jiangsu, P.R. China

Robert-Bosch-Straße 27-29, 63225 Langen, Germany

MECHANICAL DIAGRAMS

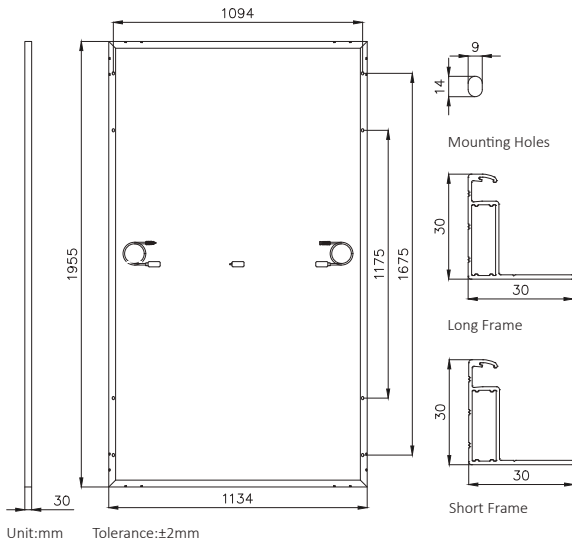

MECHANICAL PARAMETERS

Weight	21.5kg
Dimension	1955×1134×30mm
Cell Orientation	120 (6×20)
Junction Box	IP68, three diodes
Output Cable	4mm ² ,±300mm (length can be customized)
Connector	MC4 compatible
Glass	3.2mm AR coated heat strengthened glass
Frame	Anodized aluminum alloy frame
Packaging	37pcs per pallet/814pcs per 40'HC

MECHANICAL PARAMETERS

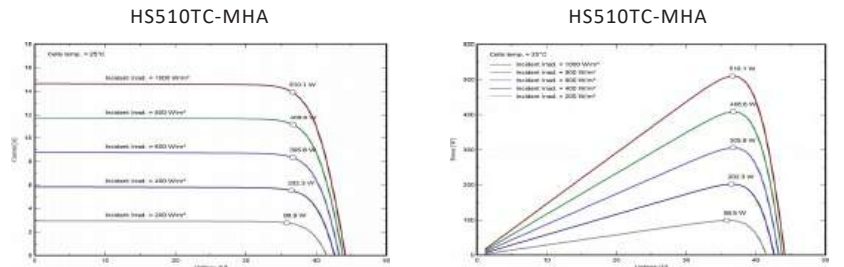

ELECTRICAL CHARACTERISTICS AT STC

Module Type	HS490TC-MHA	HS495TC-MHA	HS500TC-MHA	HS505TC-MHA	HS510TC-MHA
Testing Condition	STC	STC	STC	STC	STC
Maximum Power(Pmax/W)	490	495	500	505	510
Open Circuit Voltage(Voc/V)	43.35	43.53	43.70	43.88	44.10
Short Circuit Current(Isc/A)	14.31	14.40	14.48	14.57	14.64
Maximum Power Voltage(Vmp/V)	36.17	36.32	36.47	36.62	36.80
Maximum Power Current(Imp/A)	13.55	13.63	13.71	13.79	13.86
Module Efficiency(%)	22.2	22.4	22.6	22.9	23.1

* Under Standard Test Conditions (STC) of irradiance of 1000 W/m², spectrum AM 1.5 and cell temperature of 25°C.

ELECTRICAL CHARACTERISTICS AT NMOT

Module Type	HS490TC-MHA	HS495TC-MHA	HS500TC-MHA	HS505TC-MHA	HS510TC-MHA
Testing Condition	NMOT	NMOT	NMOT	NMOT	NMOT
Maximum Power(Pmax/W)	373	377	381	385	389
Open Circuit Voltage(Voc/V)	43.35	43.53	43.70	43.88	44.10
Short Circuit Current(Isc/A)	10.90	10.97	11.04	11.10	11.16
Maximum Power Voltage(Vmp/V)	36.17	36.32	36.47	36.62	36.80
Maximum Power Current(Imp/A)	10.32	10.38	10.45	10.51	10.56

* Under Nominal Module Operating Temperature (NMOT), irradiance of 800 W/m², spectrum AM 1.5, ambient temperature 20°C, wind speed 1 m/s.

OPERATING PARAMETERS

Operational Temperature	-40°C~+85°C
Power Output Tolerance	0~3%
Maximum System Voltage	1500V
Maximum Series Fuse Rating	25A
Nominal Operating Cell Temperature	45±2°C
Protection Class	Class II
Fire Rating	IEC Class C

*The actual test value may be slightly deviated from the technical parameters due to the difference in test methods.

MECHANICAL LOADING

Front Side Maximum Static Loading	5400Pa
Rear Side Maximum Static Loading	2400Pa
Hailstone Test	25mm Hailstone at the speed of 23m/s

TEMPERATURE RATINGS (STC)

Temperature Coefficient of Isc	+0.04%/°C
Temperature Coefficient of Voc	-0.23%/°C
Temperature Coefficient of Pmax	-0.28%/°C



560W

HORAY

TIER1
BloombergNEF

HS **186R-132** TC *Alpine* N-type Mono-facial Modules

N-type
SMBB

SMBB Half-Cell Technology
More uniform current collection capability, reducing the current heat loss of the internal cells.

CONVERSION

Higher Output Power
The output power of 132 half-cells monocrystalline modules is up to 560W.

LOW LIGHT

Low Light Features
Higher performance under low light environment.

RESISTANT

Harsh Environmental Adaptability
Strict salt spray and ammonia corrosion test by the third party.

LID
LOW LID

N-type With Very Low LID
N-type solar cell has very low LID naturally which can reduce power degradation.

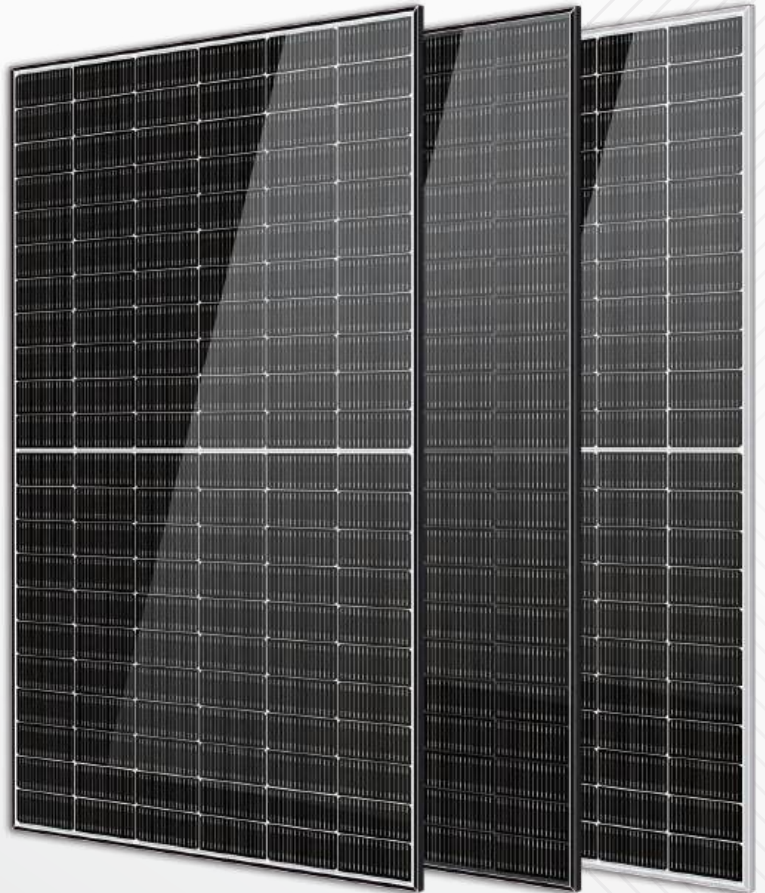

IEC61215:2021

IEC61730:2023

ISO9001:2015 Quality Management System

ISO14001:2015 Environmental Management System

IOS45001:2018 Occupational Health and Safety Management System

CE: Europe Standard

China Quality Certification Centre

Solar Product Certification

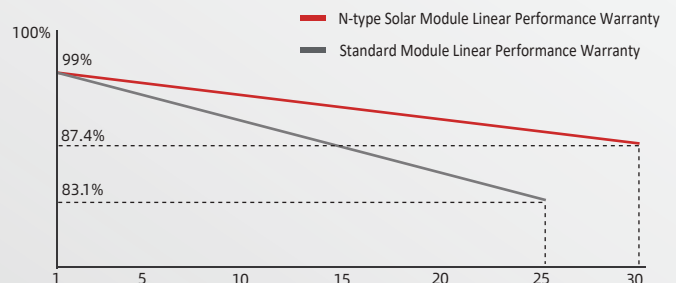
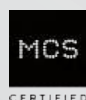

12-year product warranty



30-year linear power output warranty

HEADQUARTER: HORAY SOLAR CO., LTD.

GLOBAL MARKETING AND SERVICE: HORAY SOLAR GMBH

sales@horaysolar.com www.horaysolar.com +86-510 83580688
No.300 Huiming Road, Huishan District, 214177 Wuxi, Jiangsu, P.R. China

info@horaysolar.com www.horaysolar.com
Robert-Bosch-Straße 27-29, 63225 Langen, Germany

MECHANICAL DIAGRAMS

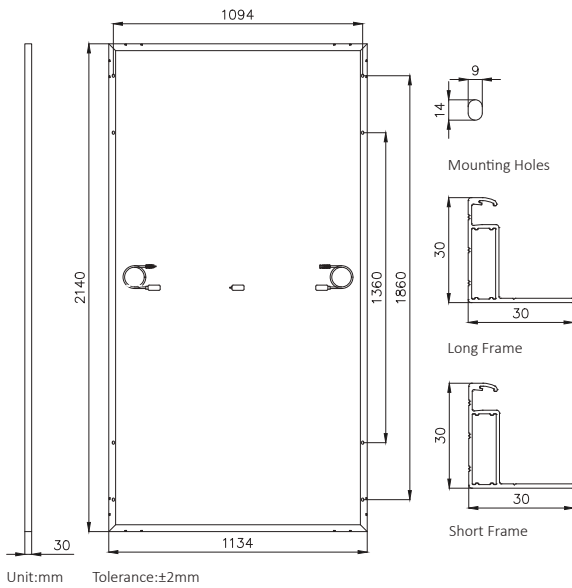

MECHANICAL PARAMETERS

Weight	24.5kg
Dimension	2140×1134×30mm
Cell Orientation	132 (6×22)
Junction Box	IP68, three diodes
Output Cable	4mm ² ,±300mm (length can be customized)
Connector	MC4 compatible
Glass	3.2mm AR coated heat strengthened glass
Frame	Anodized aluminum alloy frame
Packaging	37pcs per pallet/740pcs per 40'HC

MECHANICAL PARAMETERS

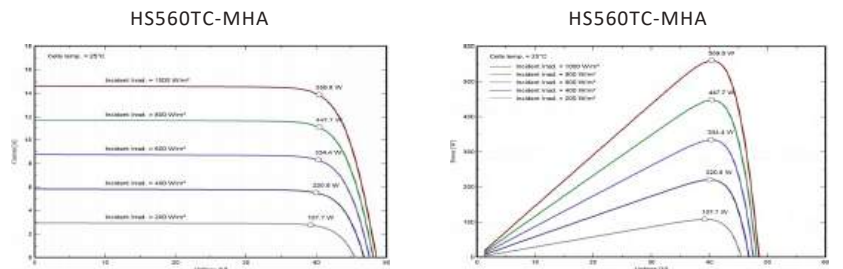

ELECTRICAL CHARACTERISTICS AT STC

Module Type	HS540TC-MHA	HS545TC-MHA	HS550TC-MHA	HS555TC-MHA	HS560TC-MHA
Testing Condition	STC	STC	STC	STC	STC
Maximum Power(Pmax/W)	540	545	550	555	560
Open Circuit Voltage(Voc/V)	47.68	47.88	48.07	48.27	48.51
Short Circuit Current(Isc/A)	14.34	14.41	14.48	14.56	14.61
Maximum Power Voltage(Vmp/V)	39.79	39.96	40.11	40.28	40.48
Maximum Power Current(Imp/A)	13.57	13.64	13.71	13.78	13.83
Module Efficiency(%)	22.3	22.5	22.7	22.9	23.1

* Under Standard Test Conditions (STC) of irradiance of 1000 W/m², spectrum AM 1.5 and cell temperature of 25°C.

ELECTRICAL CHARACTERISTICS AT NMOT

Module Type	HS540TC-MHA	HS545TC-MHA	HS550TC-MHA	HS555TC-MHA	HS560TC-MHA
Testing Condition	NMOT	NMOT	NMOT	NMOT	NMOT
Maximum Power(Pmax/W)	411	415	419	423	427
Open Circuit Voltage(Voc/V)	47.68	47.88	48.07	48.27	48.51
Short Circuit Current(Isc/A)	10.92	10.98	11.04	11.09	11.14
Maximum Power Voltage(Vmp/V)	39.79	39.96	40.11	40.28	40.48
Maximum Power Current(Imp/A)	10.34	10.39	10.45	10.50	10.54

* Under Nominal Module Operating Temperature (NMOT), irradiance of 800 W/m², spectrum AM 1.5, ambient temperature 20°C, wind speed 1 m/s.

OPERATING PARAMETERS

Operational Temperature	-40°C~+85°C
Power Output Tolerance	0~3%
Maximum System Voltage	1500V
Maximum Series Fuse Rating	25A
Nominal Operating Cell Temperature	45±2°C
Protection Class	Class II
Fire Rating	IEC Class C

*The actual test value may be slightly deviated from the technical parameters due to the difference in test methods.

MECHANICAL LOADING

Front Side Maximum Static Loading	5400Pa
Rear Side Maximum Static Loading	2400Pa
Hailstone Test	25mm Hailstone at the speed of 23m/s

TEMPERATURE RATINGS (STC)

Temperature Coefficient of Isc	+0.04%/°C
Temperature Coefficient of Voc	-0.23%/°C
Temperature Coefficient of Pmax	-0.28%/°C



610W

HORAY

TIER1
BloombergNEF

HS 186R-144 TC Alpine N-type Mono-facial Modules



SMBB Half-Cell Technology

More uniform current collection capability, reducing the current heat loss of the internal cells.



Higher Output Power

The output power of 144 half-cells monocrystalline modules is up to 610W.



Low Light Features

Higher performance under low light environment.



Harsh Environmental Adaptability

Strict salt spray and ammonia corrosion test by the third party.



N-type With Very Low LID

N-type solar cell has very low LID naturally which can reduce power degradation.

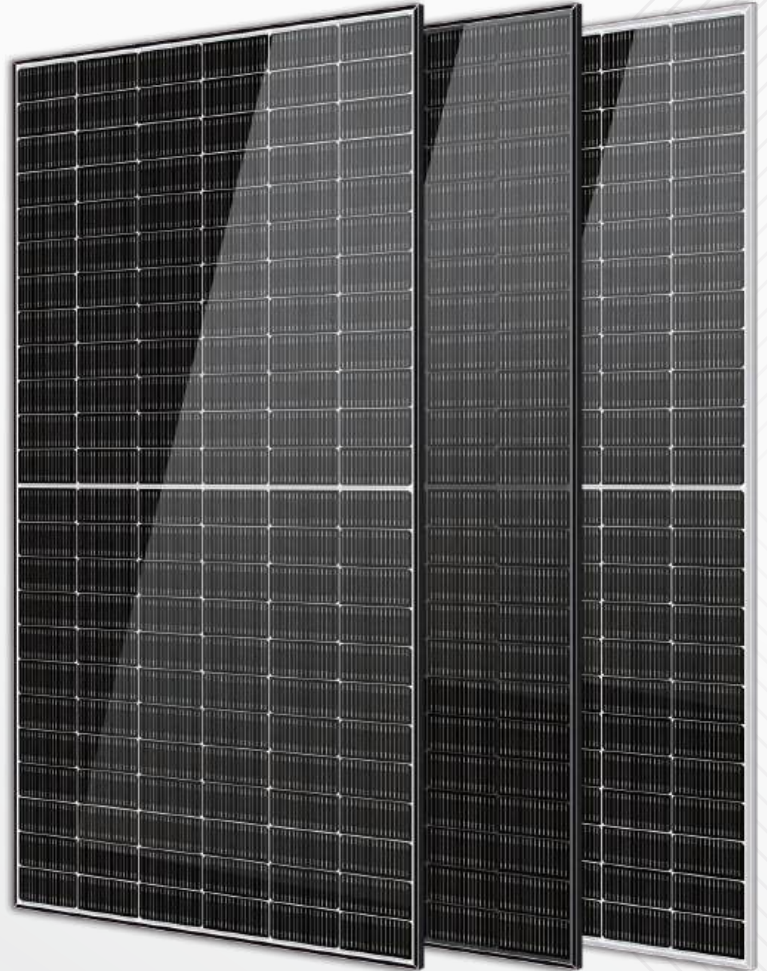

IEC61215:2021

IEC61730:2023

ISO9001:2015 Quality Management System

ISO14001:2015 Environmental Management System

IOS45001:2018 Occupational Health and Safety Management System

CE: Europe Standard

China Quality Certification Centre

Solar Product Certification

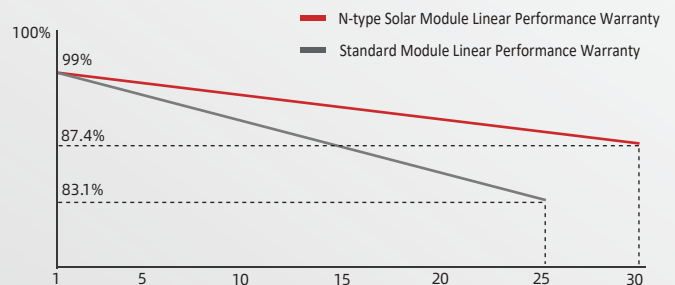

12-year product warranty



30-year linear power output warranty

HEADQUARTER: HORAY SOLAR CO., LTD.

GLOBAL MARKETING AND SERVICE: HORAY SOLAR GMBH

sales@horaysolar.com www.horaysolar.com +86-510 83580688

info@horaysolar.com www.horaysolar.com

No.300 Huiming Road, Huishan District, 214177 Wuxi, Jiangsu, P.R. China

Robert-Bosch-Straße 27-29, 63225 Langen, Germany

MECHANICAL DIAGRAMS

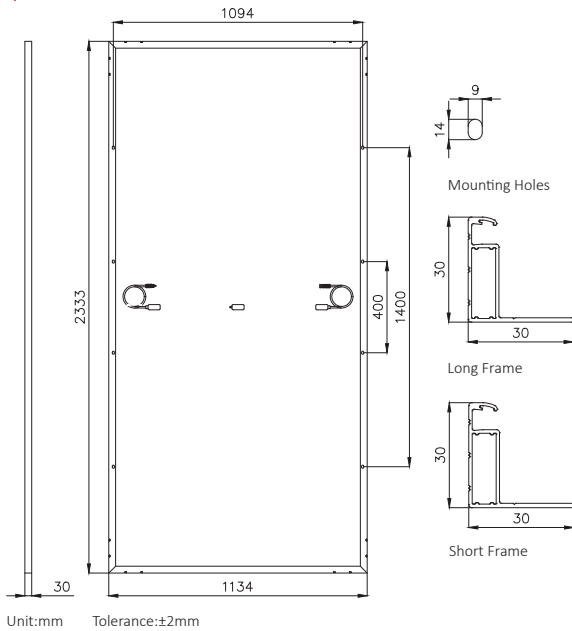

MECHANICAL PARAMETERS

Weight	27.0kg
Dimension	2333×1134×30mm
Cell Orientation	144 (6×24)
Junction Box	IP68, three diodes
Output Cable	4mm ² ,±300mm (length can be customized)
Connector	MC4 compatible
Glass	3.2mm AR coated heat strengthened glass
Frame	Anodized aluminum alloy frame
Packaging	36pcs per pallet/720pcs per 40'HC

MECHANICAL PARAMETERS

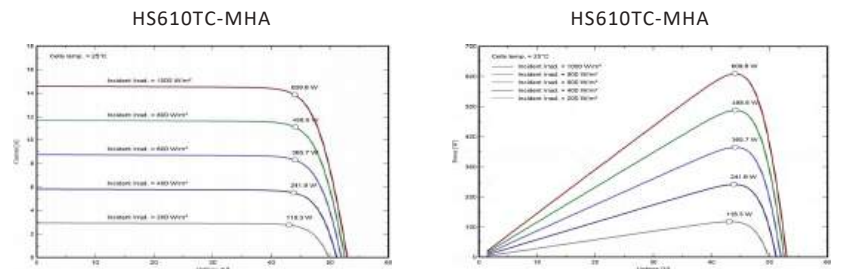

ELECTRICAL CHARACTERISTICS AT STC

Module Type	HS590TC-MHA	HS595TC-MHA	HS600TC-MHA	HS605TC-MHA	HS610TC-MHA
Testing Condition	STC	STC	STC	STC	STC
Maximum Power(Pmax/W)	590	595	600	605	610
Open Circuit Voltage(Voc/V)	52.02	52.24	52.44	52.65	52.92
Short Circuit Current(Isc/A)	14.36	14.42	14.48	14.55	14.59
Maximum Power Voltage(Vmp/V)	43.41	43.59	43.76	43.94	44.16
Maximum Power Current(Imp/A)	13.59	13.65	13.71	13.77	13.81
Module Efficiency(%)	22.3	22.5	22.7	22.9	23.1

* Under Standard Test Conditions (STC) of irradiance of 1000 W/m², spectrum AM 1.5 and cell temperature of 25°C.

ELECTRICAL CHARACTERISTICS AT NMOT

Module Type	HS590TC-MHA	HS595TC-MHA	HS600TC-MHA	HS605TC-MHA	HS610TC-MHA
Testing Condition	NMOT	NMOT	NMOT	NMOT	NMOT
Maximum Power(Pmax/W)	450	453	457	461	465
Open Circuit Voltage(Voc/V)	52.02	52.24	52.44	52.65	52.92
Short Circuit Current(Isc/A)	10.94	10.99	11.04	11.08	11.12
Maximum Power Voltage(Vmp/V)	43.41	43.59	43.76	43.94	44.16
Maximum Power Current(Imp/A)	10.36	10.40	10.45	10.49	10.53

* Under Nominal Module Operating Temperature (NMOT), irradiance of 800 W/m², spectrum AM 1.5, ambient temperature 20°C, wind speed 1 m/s.

OPERATING PARAMETERS

Operational Temperature	-40°C~+85°C
Power Output Tolerance	0~3%
Maximum System Voltage	1500V
Maximum Series Fuse Rating	25A
Nominal Operating Cell Temperature	45±2°C
Protection Class	Class II
Fire Rating	IEC Class C

*The actual test value may be slightly deviated from the technical parameters due to the difference in test methods.

MECHANICAL LOADING

Front Side Maximum Static Loading	5400Pa
Rear Side Maximum Static Loading	2400Pa
Hailstone Test	25mm Hailstone at the speed of 23m/s

TEMPERATURE RATINGS (STC)

Temperature Coefficient of Isc	+0.04%/°C
Temperature Coefficient of Voc	-0.23%/°C
Temperature Coefficient of Pmax	-0.28%/°C



475W

HORAY

TIER1
BloombergNEF

HS 191R-108 TC Basin N-type Mono-facial Modules



SMBB Half-Cell Technology

More uniform current collection capability, reducing the current heat loss of the internal cells.



Higher Output Power

The output power of 108 half-cells monocrystalline modules is up to 475W.



Low Light Features

Higher performance under low light environment.



Harsh Environmental Adaptability

Strict salt spray and ammonia corrosion test by the third party.



N-type With Very Low LID

N-type solar cell has very low LID naturally which can reduce power degradation.

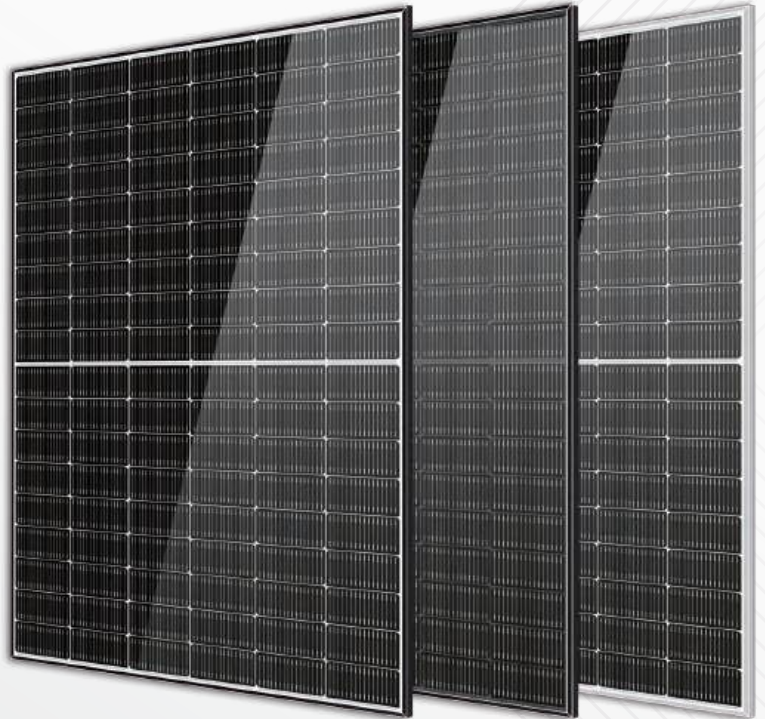

IEC61215:2021

IEC61730:2023

ISO9001:2015 Quality Management System

ISO14001:2015 Environmental Management System

IOS45001:2018 Occupational Health and Safety Management System

CE: Europe Standard

China Quality Certification Centre

Solar Product Certification

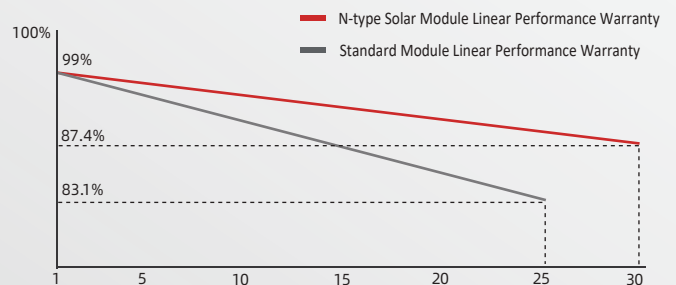

12-year product warranty



30-year linear power output warranty

HEADQUARTER: HORAY SOLAR CO., LTD.

GLOBAL MARKETING AND SERVICE: HORAY SOLAR GMBH

sales@horaysolar.com www.horaysolar.com +86-510 83580688

info@horaysolar.com www.horaysolar.com

No.300 Huiming Road, Huishan District, 214177 Wuxi, Jiangsu, P.R. China

Robert-Bosch-Straße 27-29, 63225 Langen, Germany

MECHANICAL DIAGRAMS

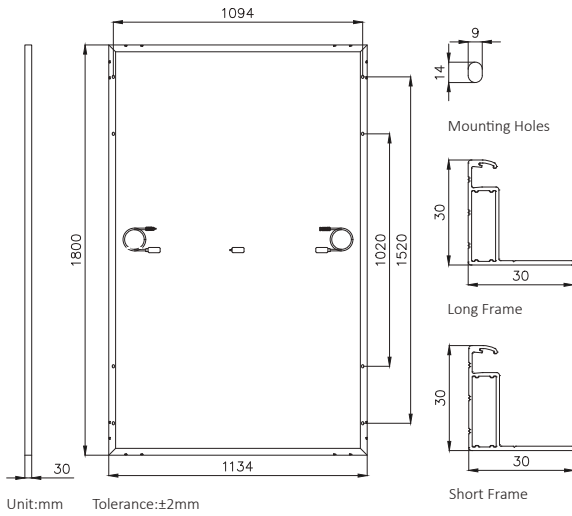

MECHANICAL PARAMETERS

Weight	21.0kg
Dimension	1800×1134×30mm
Cell Orientation	108 (6×18)
Junction Box	IP68, three diodes
Output Cable	4mm ² ,±300mm (length can be customized)
Connector	MC4 compatible
Glass	3.2mm AR coated heat strengthened glass
Frame	Anodized aluminum alloy frame
Packaging	37pcs per pallet/888pcs per 40'HC

MECHANICAL PARAMETERS

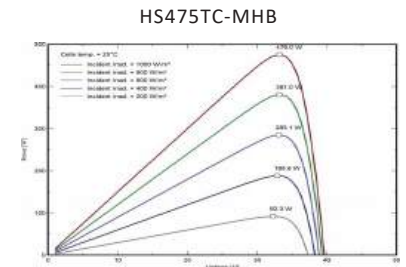
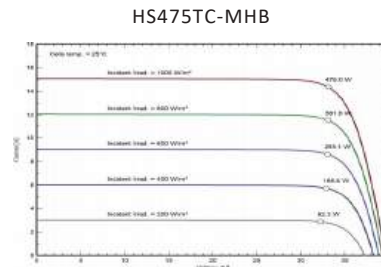

ELECTRICAL CHARACTERISTICS AT STC

Module Type	HS455TC-MHB	HS460TC-MHB	HS465TC-MHB	HS470TC-MHB	HS475TC-MHB
Testing Condition	STC	STC	STC	STC	STC
Maximum Power(Pmax/W)	455	460	465	470	475
Open Circuit Voltage(Voc/V)	38.90	39.08	39.26	39.31	39.61
Short Circuit Current(Isc/A)	14.68	14.78	14.87	15.01	15.06
Maximum Power Voltage(Vmp/V)	33.00	33.15	33.30	33.35	33.60
Maximum Power Current(Imp/A)	13.79	13.88	13.96	14.10	14.14
Module Efficiency(%)	22.3	22.6	22.8	23.0	22.3

* Under Standard Test Conditions (STC) of irradiance of 1000 W/m², spectrum AM 1.5 and cell temperature of 25°C.

ELECTRICAL CHARACTERISTICS AT NMOT

Module Type	HS455TC-MHB	HS460TC-MHB	HS465TC-MHB	HS470TC-MHB	HS475TC-MHB
Testing Condition	NMOT	NMOT	NMOT	NMOT	NMOT
Maximum Power(Pmax/W)	381	386	390	394	398
Open Circuit Voltage(Voc/V)	38.90	39.08	39.26	39.31	39.61
Short Circuit Current(Isc/A)	11.19	11.26	11.33	11.44	11.47
Maximum Power Voltage(Vmp/V)	33.00	33.15	33.30	33.35	33.60
Maximum Power Current(Imp/A)	10.51	10.57	10.64	10.74	10.77

* Under Nominal Module Operating Temperature (NMOT), irradiance of 800 W/m², spectrum AM 1.5, ambient temperature 20°C, wind speed 1 m/s.

OPERATING PARAMETERS

Operational Temperature	-40°C~+85°C
Power Output Tolerance	0~3%
Maximum System Voltage	1500V
Maximum Series Fuse Rating	30A
Nominal Operating Cell Temperature	45±2°C
Protection Class	Class II
Fire Rating	IEC Class C

*The actual test value may be slightly deviated from the technical parameters due to the difference in test methods.

MECHANICAL LOADING

Front Side Maximum Static Loading	5400Pa
Rear Side Maximum Static Loading	2400Pa
Hailstone Test	25mm Hailstone at the speed of 23m/s

TEMPERATURE RATINGS (STC)

Temperature Coefficient of Isc	+0.04%/°C
Temperature Coefficient of Voc	-0.23%/°C
Temperature Coefficient of Pmax	-0.28%/°C



520W

HORAY

TIER1
BloombergNEF

HS 191R-120 TC Basin N-type Mono-ifacial Modules

N-type
SMBB

SMBB Half-Cell Technology
More uniform current collection capability, reducing the current heat loss of the internal cells.

CONVERSION

Higher Output Power
The output power of 120 half-cells monocrystalline modules is up to 520W.

LOW LIGHT

Low Light Features
Higher performance under low light environment.

RESISTANT

Harsh Environmental Adaptability
Strict salt spray and ammonia corrosion test by the third party.

LID
LOW LID

N-type With Very Low LID
N-type solar cell has very low LID naturally which can reduce power degradation.

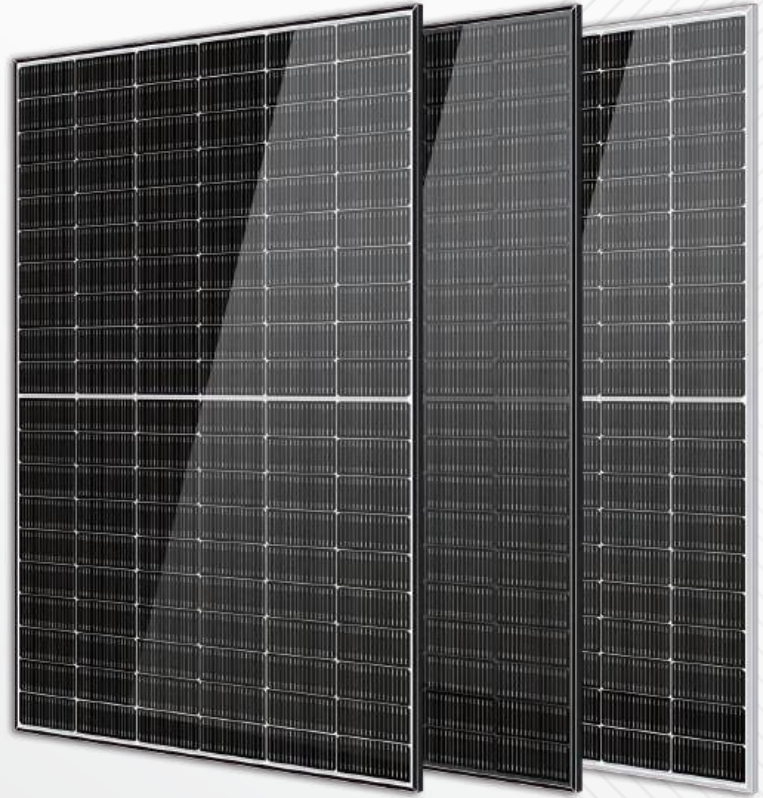

- IEC61215:2021
- IEC61730:2023
- ISO9001:2015 Quality Management System
- ISO14001:2015 Environmental Management System
- IOS45001:2018 Occupational Health and Safety Management System
- CE: Europe Standard
- China Quality Certification Centre
- Solar Product Certification

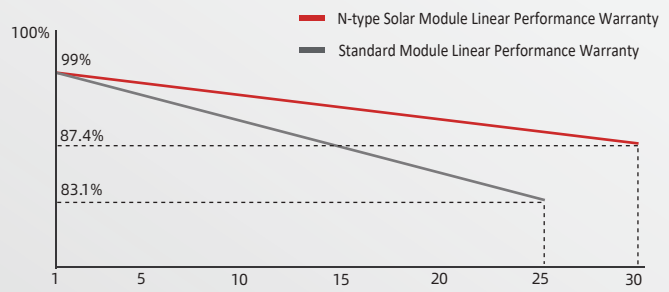

12 12-year product warranty

30 30-year linear power output warranty

HEADQUARTER: HORAY SOLAR CO., LTD. GLOBAL MARKETING AND SERVICE: HORAY SOLAR GMBH

sales@horaysolar.com www.horaysolar.com +86-510 83580688
No.300 Huiming Road, Huishan District, 214177 Wuxi, Jiangsu, P.R. China

info@horaysolar.com www.horaysolar.com
Robert-Bosch-Straße 27-29, 63225 Langen, Germany

MECHANICAL DIAGRAMS

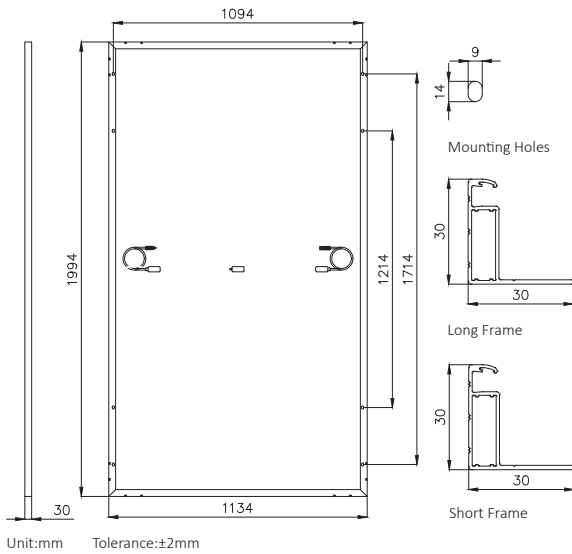

MECHANICAL PARAMETERS

Weight	23.5kg
Dimension	1994×1134×30mm
Cell Orientation	120 (6×20)
Junction Box	IP68, three diodes
Output Cable	4mm ² ,±300mm (length can be customized)
Connector	MC4 compatible
Glass	3.2mm AR coated heat strengthened glass
Frame	Anodized aluminum alloy frame
Packaging	37pcs per pallet/814pcs per 40'HC

MECHANICAL PARAMETERS

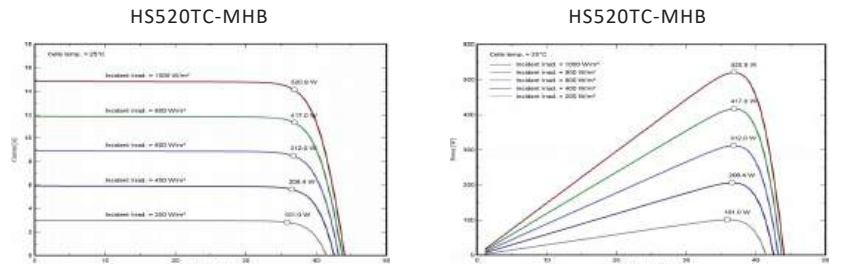

ELECTRICAL CHARACTERISTICS AT STC

Module Type	HS500TC-MHB	HS505TC-MHB	HS510TC-MHB	HS515TC-MHB	HS520TC-MHB
Testing Condition	STC	STC	STC	STC	STC
Maximum Power(Pmax/W)	500	505	510	515	520
Open Circuit Voltage(Voc/V)	43.23	43.42	43.62	43.68	44.01
Short Circuit Current(Isc/A)	14.52	14.60	14.68	14.80	14.83
Maximum Power Voltage(Vmp/V)	36.67	36.83	37.00	37.05	37.33
Maximum Power Current(Imp/A)	13.64	13.71	13.78	13.90	13.93
Module Efficiency(%)	22.1	22.3	22.6	22.8	23.0

* Under Standard Test Conditions (STC) of irradiance of 1000 W/m², spectrum AM 1.5 and cell temperature of 25°C.

ELECTRICAL CHARACTERISTICS AT NMOT

Module Type	HS500TC-MHB	HS505TC-MHB	HS510TC-MHB	HS515TC-MHB	HS520TC-MHB
Testing Condition	NMOT	NMOT	NMOT	NMOT	NMOT
Maximum Power(Pmax/W)	419	423	427	432	436
Open Circuit Voltage(Voc/V)	43.23	43.42	43.62	43.68	44.01
Short Circuit Current(Isc/A)	11.07	11.13	11.19	11.28	11.30
Maximum Power Voltage(Vmp/V)	36.67	36.83	37.00	37.05	37.33
Maximum Power Current(Imp/A)	10.39	10.45	10.50	10.59	10.61

* Under Nominal Module Operating Temperature (NMOT), irradiance of 800 W/m², spectrum AM 1.5, ambient temperature 20°C, wind speed 1 m/s.

OPERATING PARAMETERS

Operational Temperature	-40°C~+85°C
Power Output Tolerance	0~3%
Maximum System Voltage	1500V
Maximum Series Fuse Rating	30A
Nominal Operating Cell Temperature	45±2°C
Protection Class	Class II
Fire Rating	IEC Class C

*The actual test value may be slightly deviated from the technical parameters due to the difference in test methods.

MECHANICAL LOADING

Front Side Maximum Static Loading	5400Pa
Rear Side Maximum Static Loading	2400Pa
Hailstone Test	25mm Hailstone at the speed of 23m/s

TEMPERATURE RATINGS (STC)

Temperature Coefficient of Isc	+0.04%/°C
Temperature Coefficient of Voc	-0.23%/°C
Temperature Coefficient of Pmax	-0.28%/°C



570W

HORAY

TIER1
BloombergNEF

HS **191R-132** TC Basin N-type Mono-facial Modules

N-type
SMBB

SMBB Half-Cell Technology
More uniform current collection capability, reducing the current heat loss of the internal cells.

CONVERSION

Higher Output Power
The output power of 132 half-cells monocrystalline modules is up to 570W.

LOW LIGHT

Low Light Features
Higher performance under low light environment.

RESISTANT

Harsh Environmental Adaptability
Strict salt spray and ammonia corrosion test by the third party.

LID
LOW LID

N-type With Very Low LID
N-type solar cell has very low LID naturally which can reduce power degradation.

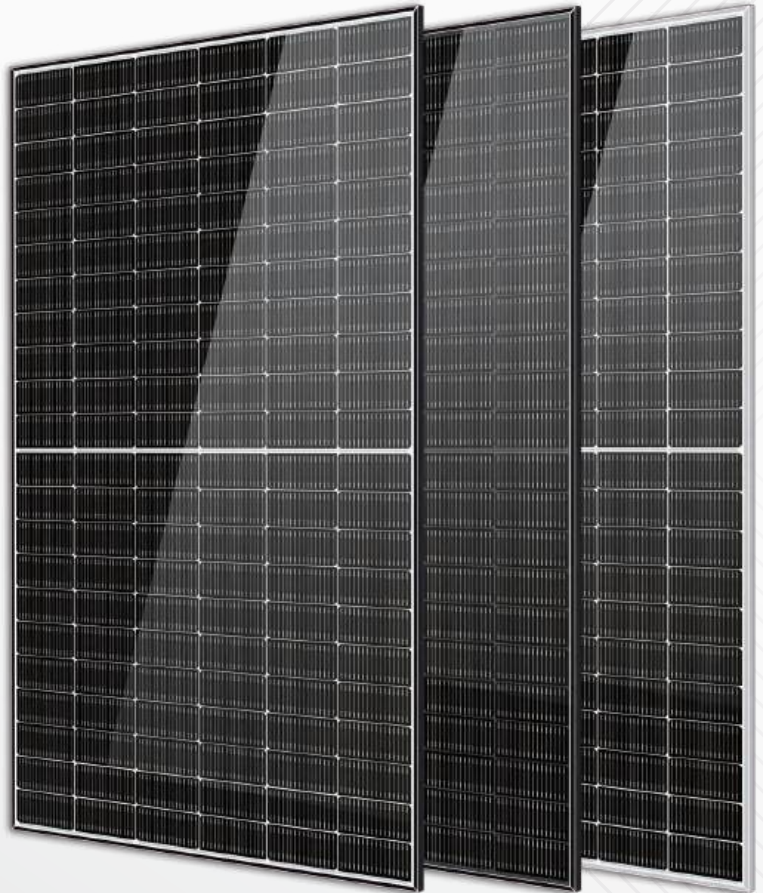

- IEC61215:2021
- IEC61730:2023
- ISO9001:2015 Quality Management System
- ISO14001:2015 Environmental Management System
- IOS45001:2018 Occupational Health and Safety Management System
- CE: Europe Standard
- China Quality Certification Centre
- Solar Product Certification

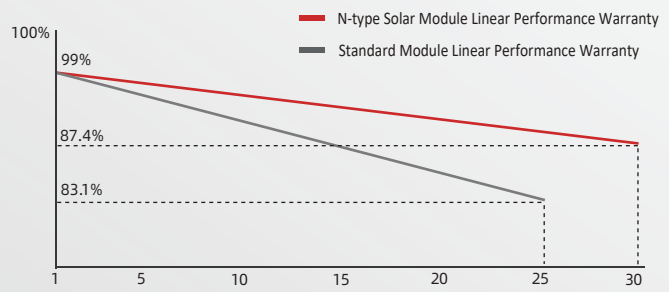

12 12-year product warranty

30 30-year linear power output warranty

HEADQUARTER: HORAY SOLAR CO., LTD. GLOBAL MARKETING AND SERVICE: HORAY SOLAR GMBH

sales@horaysolar.com www.horaysolar.com +86-510 83580688
No.300 Huiming Road, Huishan District, 214177 Wuxi, Jiangsu, P.R. China

info@horaysolar.com www.horaysolar.com
Robert-Bosch-Straße 27-29, 63225 Langen, Germany

MECHANICAL DIAGRAMS

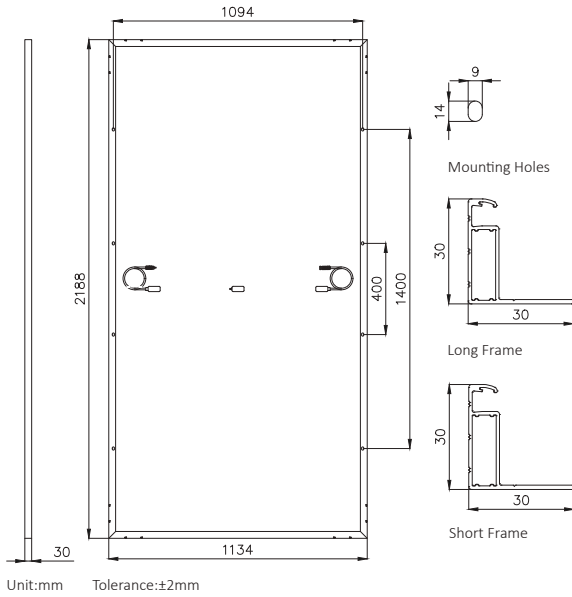

MECHANICAL PARAMETERS

Weight	25.5kg
Dimension	2188×1134×30mm
Cell Orientation	132 (6×22)
Junction Box	IP68, three diodes
Output Cable	4mm ² ,±300mm (length can be customized)
Connector	MC4 compatible
Glass	3.2mm AR coated heat strengthened glass
Frame	Anodized aluminum alloy frame
Packaging	37pcs per pallet/740pcs per 40'HC

MECHANICAL PARAMETERS

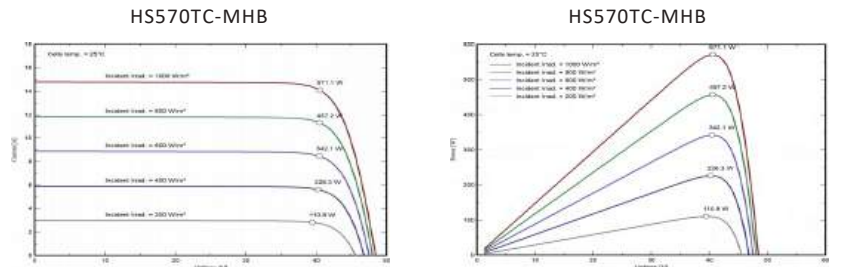

ELECTRICAL CHARACTERISTICS AT STC

Module Type	HS550TC-MHB	HS555TC-MHB	HS560TC-MHB	HS565TC-MHB	HS570TC-MHB
Testing Condition	STC	STC	STC	STC	STC
Maximum Power(Pmax/W)	550	555	560	565	570
Open Circuit Voltage(Voc/V)	47.55	47.76	47.98	48.05	48.41
Short Circuit Current(Isc/A)	14.52	14.59	14.65	14.76	14.78
Maximum Power Voltage(Vmp/V)	40.33	40.52	40.70	40.76	41.07
Maximum Power Current(Imp/A)	13.64	13.70	13.76	13.86	13.88
Module Efficiency(%)	22.2	22.4	22.6	22.8	23.0

* Under Standard Test Conditions (STC) of irradiance of 1000 W/m², spectrum AM 1.5 and cell temperature of 25°C.

ELECTRICAL CHARACTERISTICS AT NMOT

Module Type	HS550TC-MHB	HS555TC-MHB	HS560TC-MHB	HS565TC-MHB	HS570TC-MHB
Testing Condition	NMOT	NMOT	NMOT	NMOT	NMOT
Maximum Power(Pmax/W)	461	465	469	474	478
Open Circuit Voltage(Voc/V)	47.55	47.76	47.98	48.05	48.41
Short Circuit Current(Isc/A)	11.07	11.12	11.17	11.25	11.26
Maximum Power Voltage(Vmp/V)	40.33	40.52	40.70	40.76	41.07
Maximum Power Current(Imp/A)	10.39	10.44	10.48	10.56	10.58

* Under Nominal Module Operating Temperature (NMOT), irradiance of 800 W/m², spectrum AM 1.5, ambient temperature 20°C, wind speed 1 m/s.

OPERATING PARAMETERS

Operational Temperature	-40°C~+85°C
Power Output Tolerance	0~3%
Maximum System Voltage	1500V
Maximum Series Fuse Rating	30A
Nominal Operating Cell Temperature	45±2°C
Protection Class	Class II
Fire Rating	IEC Class C

*The actual test value may be slightly deviated from the technical parameters due to the difference in test methods.

MECHANICAL LOADING

Front Side Maximum Static Loading	5400Pa
Rear Side Maximum Static Loading	2400Pa
Hailstone Test	25mm Hailstone at the speed of 23m/s

TEMPERATURE RATINGS (STC)

Temperature Coefficient of Isc	+0.04%/°C
Temperature Coefficient of Voc	-0.23%/°C
Temperature Coefficient of Pmax	-0.28%/°C



620W

HORAY

TIER1
BloombergNEF

HS **191R-144** TC *Basin* N-type Mono-facial Modules

N-type
SMBB
SMBB Half-Cell Technology
More uniform current collection capability, reducing the current heat loss of the internal cells.

CONVERSION
Higher Output Power
The output power of 144 half-cells monocrystalline modules is up to 620W.

LOW LIGHT
Low Light Features
Higher performance under low light environment.

RESISTANT
Harsh Environmental Adaptability
Strict salt spray and ammonia corrosion test by the third party.

LID
LOW LID
N-type With Very Low LID
N-type solar cell has very low LID naturally which can reduce power degradation.

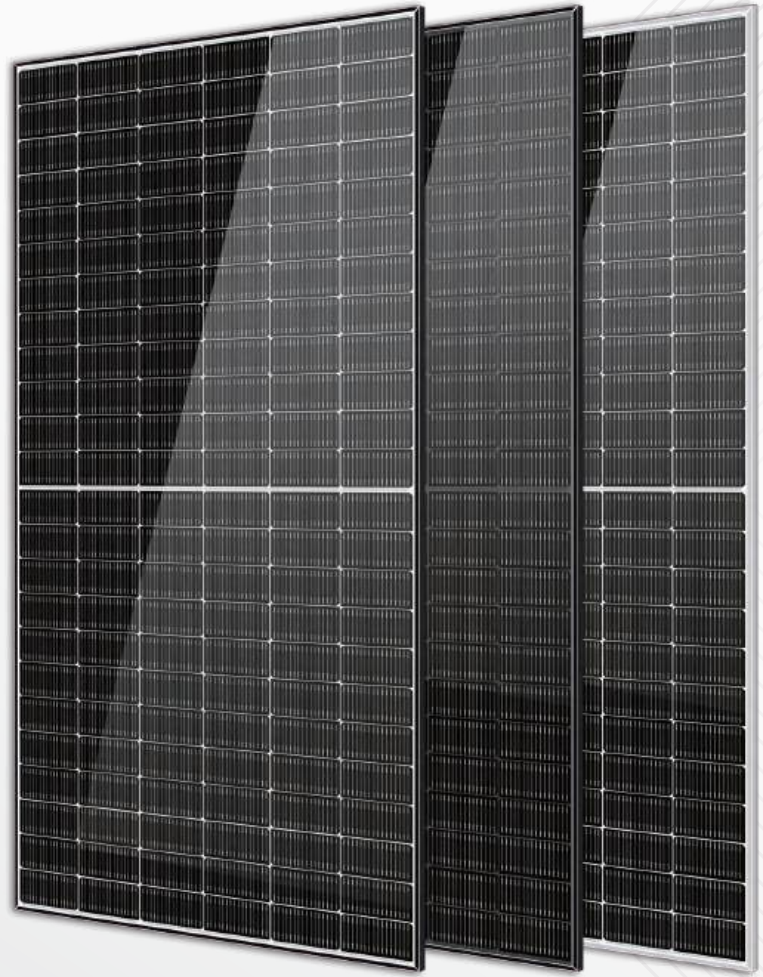

- IEC61215:2021
- IEC61730:2023
- ISO9001:2015 Quality Management System
- ISO14001:2015 Environmental Management System
- IOS45001:2018 Occupational Health and Safety Management System
- CE: Europe Standard
- China Quality Certification Centre
- Solar Product Certification

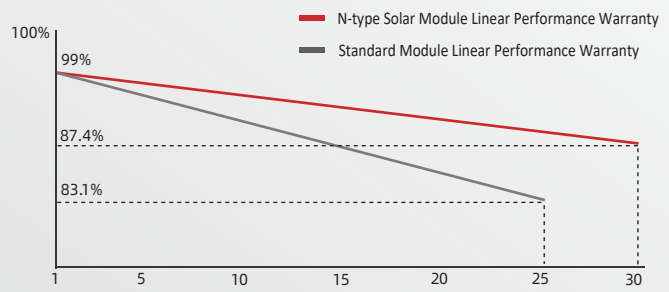

12 12-year product warranty

30 30-year linear power output warranty

HEADQUARTER: HORAY SOLAR CO., LTD. GLOBAL MARKETING AND SERVICE: HORAY SOLAR GMBH

sales@horaysolar.com www.horaysolar.com +86-510 83580688
No.300 Huiming Road, Huishan District, 214177 Wuxi, Jiangsu, P.R. China

info@horaysolar.com www.horaysolar.com
Robert-Bosch-Straße 27-29, 63225 Langen, Germany

MECHANICAL DIAGRAMS

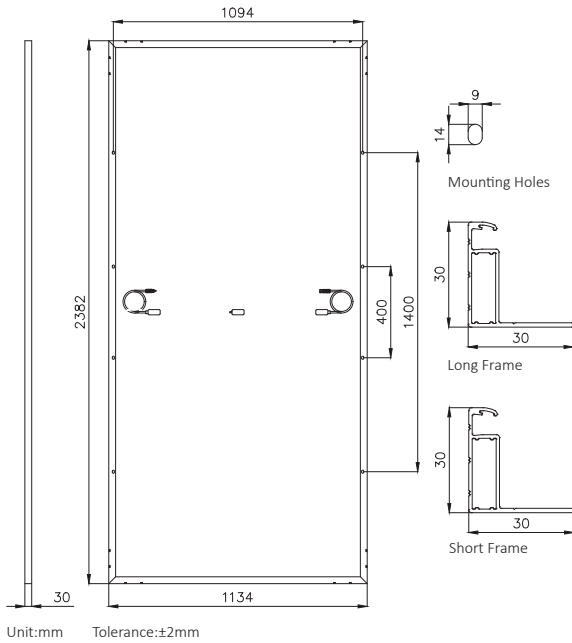

MECHANICAL PARAMETERS

Weight	28.0kg
Dimension	2382×1134×30mm
Cell Orientation	144 (6×24)
Junction Box	IP68, three diodes
Output Cable	4mm ² ,±300mm (length can be customized)
Connector	MC4 compatible
Glass	3.2mm AR coated heat strengthened glass
Frame	Anodized aluminum alloy frame
Packaging	36pcs per pallet/720pcs per 40'HC

MECHANICAL PARAMETERS

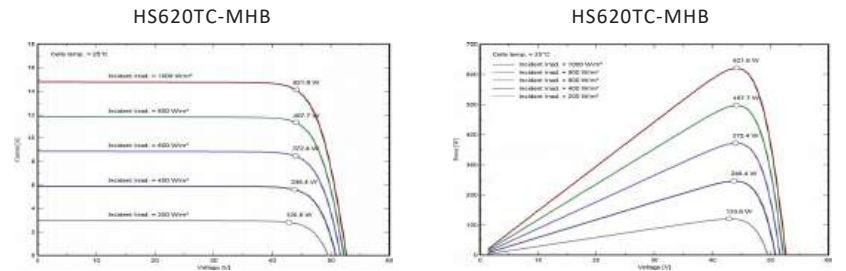

ELECTRICAL CHARACTERISTICS AT STC

Module Type	HS600TC-MHB	HS605TC-MHB	HS610TC-MHB	HS615TC-MHB	HS620TC-MHB
Testing Condition	STC	STC	STC	STC	STC
Maximum Power(Pmax/W)	600	605	610	615	620
Open Circuit Voltage(Voc/V)	51.80	52.00	52.20	52.40	52.60
Short Circuit Current(Isc/A)	14.54	14.60	14.66	14.72	14.78
Maximum Power Voltage(Vmp/V)	44.00	44.20	44.40	44.60	44.80
Maximum Power Current(Imp/A)	13.64	13.69	13.74	13.79	13.84
Module Efficiency(%)	22.2	22.4	22.6	22.8	23.0

* Under Standard Test Conditions (STC) of irradiance of 1000 W/m², spectrum AM 1.5 and cell temperature of 25°C.

ELECTRICAL CHARACTERISTICS AT NMOT

Module Type	HS600TC-MHB	HS605TC-MHB	HS610TC-MHB	HS615TC-MHB	HS620TC-MHB
Testing Condition	NMOT	NMOT	NMOT	NMOT	NMOT
Maximum Power(Pmax/W)	503	507	511	515	520
Open Circuit Voltage(Voc/V)	51.80	52.00	52.20	52.40	52.60
Short Circuit Current(Isc/A)	11.08	11.13	11.17	11.22	11.26
Maximum Power Voltage(Vmp/V)	44.00	44.20	44.40	44.60	44.80
Maximum Power Current(Imp/A)	10.39	10.43	10.47	10.51	10.55

* Under Nominal Module Operating Temperature (NMOT), irradiance of 800 W/m², spectrum AM 1.5, ambient temperature 20°C, wind speed 1 m/s.

OPERATING PARAMETERS

Operational Temperature	-40°C~+85°C
Power Output Tolerance	0~3%
Maximum System Voltage	1500V
Maximum Series Fuse Rating	30A
Nominal Operating Cell Temperature	45±2°C
Protection Class	Class II
Fire Rating	IEC Class C

*The actual test value may be slightly deviated from the technical parameters due to the difference in test methods.

MECHANICAL LOADING

Front Side Maximum Static Loading	5400Pa
Rear Side Maximum Static Loading	2400Pa
Hailstone Test	25mm Hailstone at the speed of 23m/s

TEMPERATURE RATINGS (STC)

Temperature Coefficient of Isc	+0.04%/°C
Temperature Coefficient of Voc	-0.23%/°C
Temperature Coefficient of Pmax	-0.28%/°C



430~450 Watt

HORAY



HS **182-108** TC Ocean N-type Mono-facial Modules



SMBB Half-Cell Technology

More uniform current collection capability, reducing the current heat loss of the internal cells.



Higher Output Power

The output power of 108 half-cells monocrystalline modules is up to 450W.



Low Light Features

Higher performance under low light environment.



Harsh Environmental Adaptability

Strict salt spray and ammonia corrosion test by the third party.



N-type With Very Low LID

N-type solar cell has very low LID naturally which can reduce power degradation.

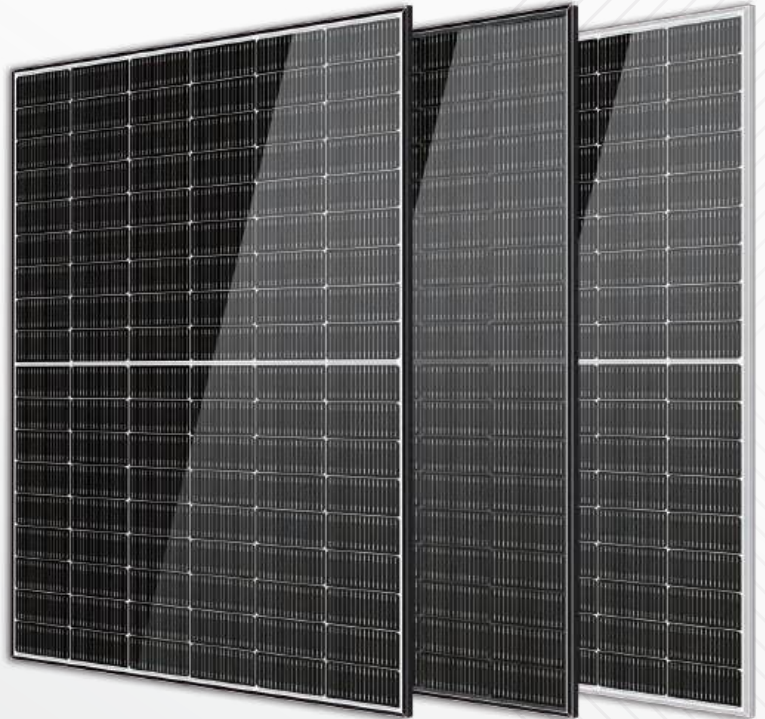

IEC61215:2021

IEC61730:2023

ISO9001:2015 Quality Management System

ISO14001:2015 Environmental Management System

ISO45001:2018 Occupational Health and Safety Management System

CE: Europe Standard

China Quality Certification Centre

Solar Product Certification

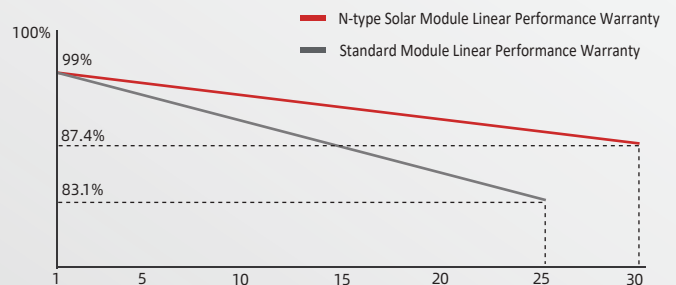

12-year product warranty



30-year linear power output warranty

HEADQUARTER: HORAY SOLAR CO., LTD.

GLOBAL MARKETING AND SERVICE: HORAY SOLAR GMBH

sales@horaysolar.com www.horaysolar.com +86-510 83580688

info@horaysolar.com www.horaysolar.com

No.300 Huiming Road, Huishan District, 214177 Wuxi, Jiangsu, P.R. China

Robert-Bosch-Straße 27-29, 63225 Langen, Germany

MECHANICAL DIAGRAMS

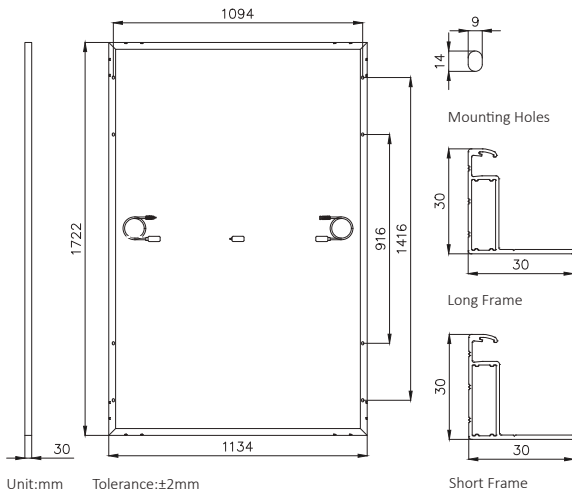

MECHANICAL PARAMETERS

Weight	20.5kg
Dimension	1722×1134×30mm
Cell Orientation	108 (6×18)
Junction Box	IP68, three diodes
Output Cable	4mm ² ,±1100mm (length can be customized)
Connector	MC4 compatible
Glass	3.2mm AR coated heat strengthened glass
Frame	Anodized aluminum alloy frame
Packaging	37pcs per pallet/962pcs per 40'HC

MECHANICAL PARAMETERS

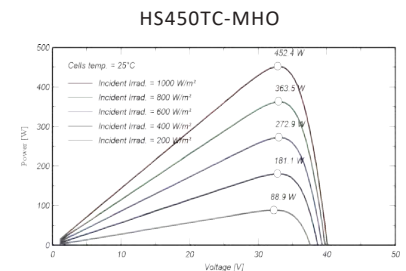
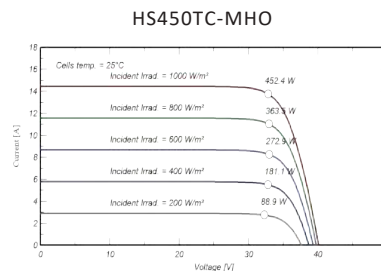

ELECTRICAL CHARACTERISTICS AT STC

Module Type	HS430TC-MHO	HS435TC-MHO	HS440TC-MHO	HS445C-MHO	HS450TC-MHO
Testing Condition	STC	STC	STC	STC	STC
Maximum Power(Pmax/W)	430	435	440	445	450
Open Circuit Voltage(Voc/V)	39.30	39.50	39.70	39.90	40.10
Short Circuit Current(Isc/A)	14.15	14.22	14.30	14.37	14.45
Maximum Power Voltage(Vmp/V)	32.84	33.04	33.24	33.44	33.64
Maximum Power Current(Imp/A)	13.10	13.17	13.24	13.31	13.38
Module Efficiency(%)	22.0	22.3	22.5	22.8	23.0

* Under Standard Test Conditions (STC) of irradiance of 1000 W/m², spectrum AM 1.5 and cell temperature of 25°C.

ELECTRICAL CHARACTERISTICS AT NMOT

Module Type	HS430TC-MHO	HS435TC-MHO	HS440C-MHO	HS445TC-MHO	HS450TC-MHO
Testing Condition	NMOT	NMOT	NMOT	NMOT	NMOT
Maximum Power(Pmax/W)	328	332	336	340	344
Open Circuit Voltage(Voc/V)	37.10	37.30	37.50	37.70	37.90
Short Circuit Current(Isc/A)	11.43	11.49	11.55	11.61	11.67
Maximum Power Voltage(Vmp/V)	30.50	30.70	30.90	31.10	31.30
Maximum Power Current(Imp/A)	10.74	10.80	10.86	10.93	10.99

* Under Nominal Module Operating Temperature (NMOT), irradiance of 800 W/m², spectrum AM 1.5, ambient temperature 20°C, wind speed 1 m/s.

OPERATING PARAMETERS

Operational Temperature	-40°C~+85°C
Power Output Tolerance	0~3%
Maximum System Voltage	1500V
Maximum Series Fuse Rating	25A
Nominal Operating Cell Temperature	45±2°C
Protection Class	Class II
Fire Rating	IEC Class C

*The actual test value may be slightly deviated from the technical parameters due to the difference in test methods.

MECHANICAL LOADING

Front Side Maximum Static Loading	5400Pa
Rear Side Maximum Static Loading	2400Pa
Hailstone Test	25mm Hailstone at the speed of 23m/s

TEMPERATURE RATINGS (STC)

Temperature Coefficient of Isc	+0.04%/°C
Temperature Coefficient of Voc	-0.23%/°C
Temperature Coefficient of Pmax	-0.28%/°C



480~500 Watt

HORAY



HS **182-120** TC Ocean N-type Mono-facial Modules



SMBB Half-Cell Technology

More uniform current collection capability, reducing the current heat loss of the internal cells.



Higher Output Power

The output power of 120 half-cells monocrystalline modules is up to 500W.



Low Light Features

Higher performance under low light environment.



Harsh Environmental Adaptability

Strict salt spray and ammonia corrosion test by the third party.



N-type With Very Low LID

N-type solar cell has very low LID naturally which can reduce power degradation.

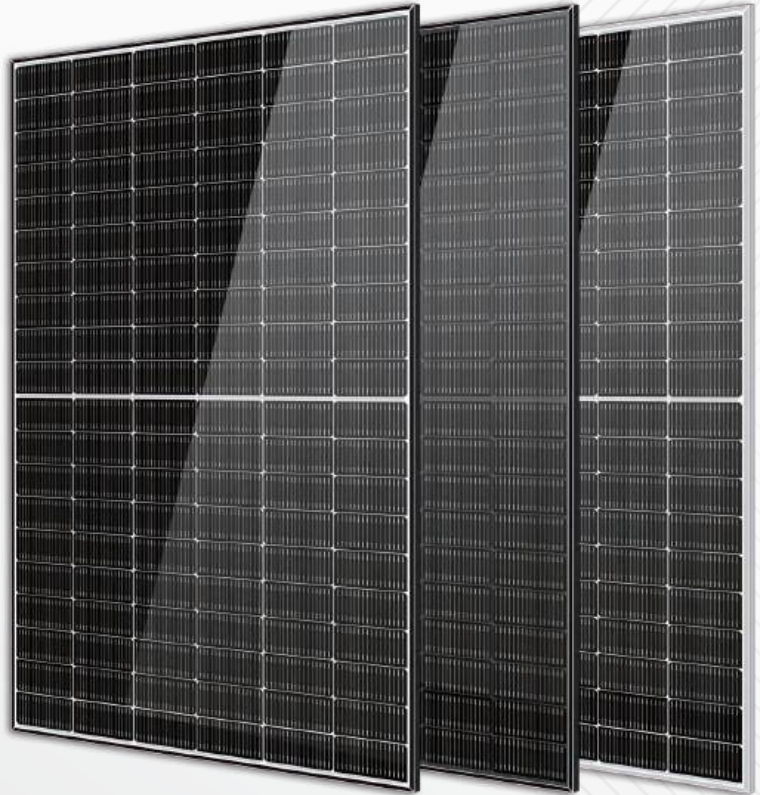

IEC61215:2021

IEC61730:2023

ISO9001:2015 Quality Management System

ISO14001:2015 Environmental Management System

ISO45001:2018 Occupational Health and Safety Management System

CE: Europe Standard

China Quality Certification Centre

Solar Product Certification

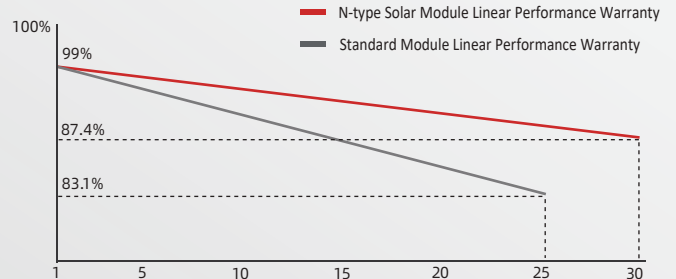

12-year product warranty



30-year linear power output warranty

HEADQUARTER: HORAY SOLAR CO., LTD.

GLOBAL MARKETING AND SERVICE: HORAY SOLAR GMBH

sales@horaysolar.com www.horaysolar.com +86-510 83580688
No.300 Huiming Road, Huishan District, 214177 Wuxi, Jiangsu, P.R. China

info@horaysolar.com www.horaysolar.com
Robert-Bosch-Straße 27-29, 63225 Langen, Germany

MECHANICAL DIAGRAMS

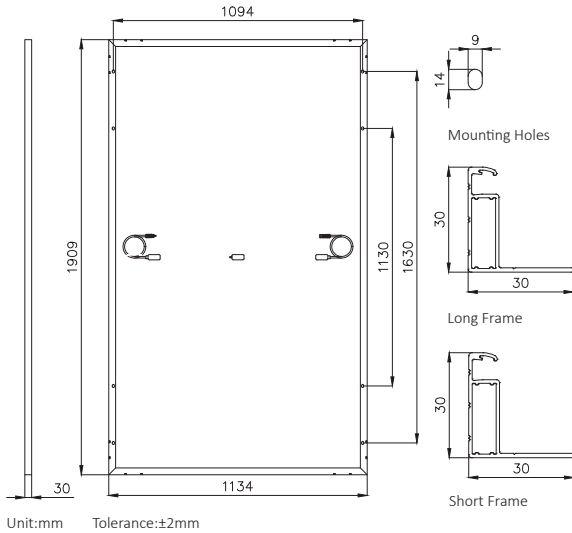

MECHANICAL PARAMETERS

Weight	23.0kg
Dimension	1909×1134×30mm
Cell Orientation	120 (6×20)
Junction Box	IP68, three diodes
Output Cable	4mm ² ,±1100mm (length can be customized)
Connector	MC4 compatible
Glass	3.2mm AR coated heat strengthened glass
Frame	Anodized aluminum alloy frame
Packaging	37pcs per pallet/888pcs per 40'HC

MECHANICAL PARAMETERS

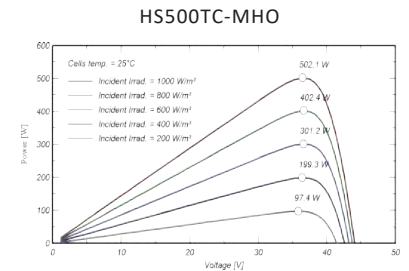
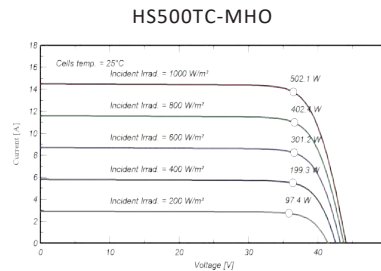

ELECTRICAL CHARACTERISTICS AT STC

Module Type	HS480TC-MHO	HS485TC-MHO	HS490TC-MHO	HS495TC-MHO	HS500TC-MHO
Testing Condition	STC	STC	STC	STC	STC
Maximum Power(Pmax/W)	480	485	490	495	500
Open Circuit Voltage(Voc/V)	43.26	43.46	43.66	43.86	44.06
Short Circuit Current(Isc/A)	14.22	14.30	14.37	14.43	14.50
Maximum Power Voltage(Vmp/V)	36.44	36.64	36.84	37.04	37.24
Maximum Power Current(Imp/A)	13.17	13.23	13.31	13.36	13.43
Module Efficiency(%)	22.2	22.4	22.6	22.9	23.1

* Under Standard Test Conditions (STC) of irradiance of 1000 W/m², spectrum AM 1.5 and cell temperature of 25°C.

ELECTRICAL CHARACTERISTICS AT NMOT

Module Type	HS480TC-MHO	HS485TC-MHO	HS490TC-MHO	HS495TC-MHO	HS500TC-MHO
Testing Condition	NMOT	NMOT	NMOT	NMOT	NMOT
Maximum Power(Pmax/W)	365	369	374	378	382
Open Circuit Voltage(Voc/V)	41.00	41.20	41.40	41.60	41.80
Short Circuit Current(Isc/A)	11.49	11.55	11.61	11.66	11.72
Maximum Power Voltage(Vmp/V)	33.80	34.00	34.20	34.40	34.60
Maximum Power Current(Imp/A)	10.82	10.88	10.93	10.99	11.04

* Under Nominal Module Operating Temperature (NMOT), irradiance of 800 W/m², spectrum AM 1.5, ambient temperature 20°C, wind speed 1 m/s.

OPERATING PARAMETERS

Operational Temperature	-40°C~+85°C
Power Output Tolerance	0~3%
Maximum System Voltage	1500V
Maximum Series Fuse Rating	25A
Nominal Operating Cell Temperature	45±2°C
Protection Class	Class II
Fire Rating	IEC Class C

*The actual test value may be slightly deviated from the technical parameters due to the difference in test methods.

MECHANICAL LOADING

Front Side Maximum Static Loading	5400Pa
Rear Side Maximum Static Loading	2400Pa
Hailstone Test	25mm Hailstone at the speed of 23m/s

TEMPERATURE RATINGS (STC)

Temperature Coefficient of Isc	+0.04%/°C
Temperature Coefficient of Voc	-0.23%/°C
Temperature Coefficient of Pmax	-0.28%/°C



530~550 Watt

HORAY

TIER1
BloombergNEF

HS **182-132** TC Ocean N-type Mono-facial Modules

N-type
SMBB

SMBB Half-Cell Technology
More uniform current collection capability, reducing the current heat loss of the internal cells.

CONVERSION

Higher Output Power
The output power of 132 half-cells monocrystalline modules is up to 550W.

LOW LIGHT

Low Light Features
Higher performance under low light environment.

RESISTANT

Harsh Environmental Adaptability
Strict salt spray and ammonia corrosion test by the third party.

LID
LOW LID

N-type With Very Low LID
N-type solar cell has very low LID naturally which can reduce power degradation.

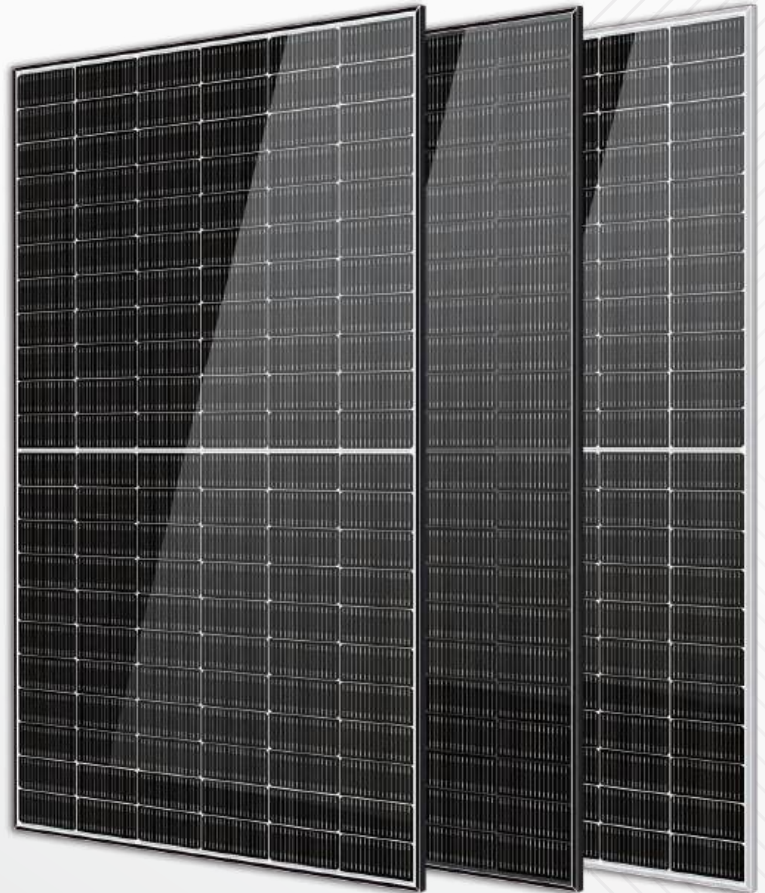

IEC61215:2021

IEC61730:2023

ISO9001:2015 Quality Management System

ISO14001:2015 Environmental Management System

ISO45001:2018 Occupational Health and Safety Management System

CE: Europe Standard

China Quality Certification Centre

Solar Product Certification

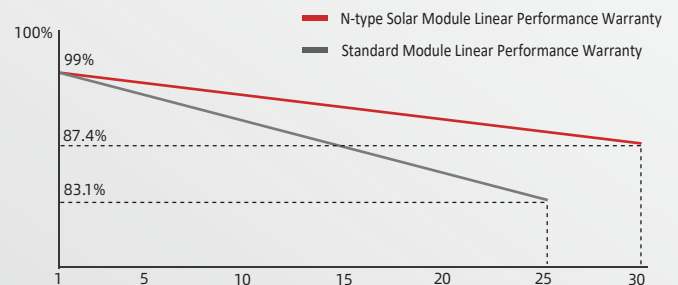
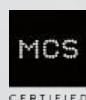

12

12-year product warranty

30

30-year linear power output warranty

HEADQUARTER: HORAY SOLAR CO., LTD.

GLOBAL MARKETING AND SERVICE: HORAY SOLAR GMBH

sales@horaysolar.com www.horaysolar.com +86-510 83580688

info@horaysolar.com www.horaysolar.com

No.300 Huiming Road, Huishan District, 214177 Wuxi, Jiangsu, P.R. China

Robert-Bosch-Straße 27-29, 63225 Langen, Germany

MECHANICAL DIAGRAMS

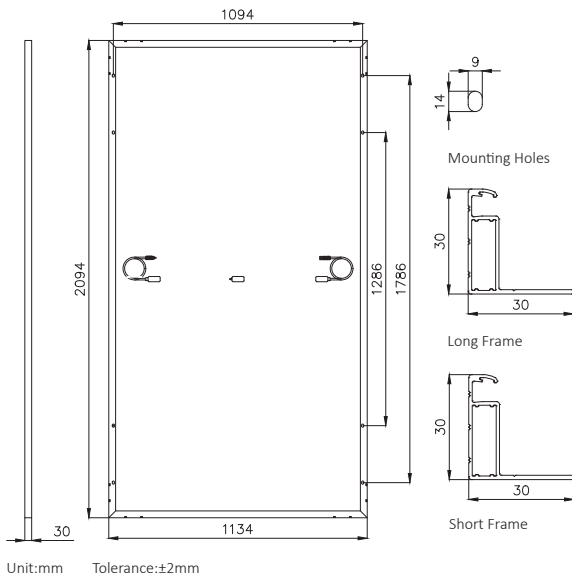

MECHANICAL PARAMETERS

Weight	24.5kg
Dimension	2094×1134×30mm
Cell Orientation	132 (6×22)
Junction Box	IP68, three diodes
Output Cable	4mm ² ,±300mm (length can be customized)
Connector	MC4 compatible
Glass	3.2mm AR coated heat strengthened glass
Frame	Anodized aluminum alloy frame
Packaging	37pcs per pallet/814pcs per 40'HC

MECHANICAL PARAMETERS

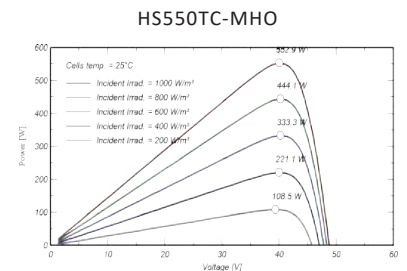
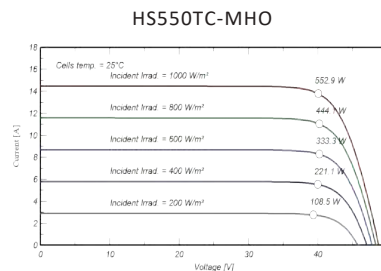

ELECTRICAL CHARACTERISTICS AT STC

Module Type	HS530TC-MHO	HS535TC-MHO	HS540TC-MHO	HS545TC-MHO	HS550C-MHO
Testing Condition	STC	STC	STC	STC	STC
Maximum Power(Pmax/W)	530	535	540	545	550
Open Circuit Voltage(Voc/V)	47.81	48.04	48.27	48.52	48.76
Short Circuit Current(Isc/A)	14.22	14.29	14.35	14.41	14.47
Maximum Power Voltage(Vmp/V)	40.24	40.44	40.64	40.84	41.04
Maximum Power Current(Imp/A)	13.17	13.23	13.29	13.34	13.40
Module Efficiency(%)	22.3	22.5	22.7	23.0	23.2

* Under Standard Test Conditions (STC) of irradiance of 1000 W/m², spectrum AM 1.5 and cell temperature of 25°C.

ELECTRICAL CHARACTERISTICS AT NMOT

Module Type	HS530TC-MHO	HS535TC-MHO	HS540TC-MHO	HS545TC-MHO	HS550TC-MHO
Testing Condition	NMOT	NMOT	NMOT	NMOT	NMOT
Maximum Power(Pmax/W)	401	408	412	416	420
Open Circuit Voltage(Voc/V)	45.20	45.50	45.80	46.00	46.30
Short Circuit Current(Isc/A)	11.49	11.54	11.59	11.64	11.69
Maximum Power Voltage(Vmp/V)	37.30	37.60	37.70	37.90	38.10
Maximum Power Current(Imp/A)	10.81	10.86	10.92	10.98	11.02

* Under Nominal Module Operating Temperature (NMOT), irradiance of 800 W/m², spectrum AM 1.5, ambient temperature 20°C, wind speed 1 m/s.

OPERATING PARAMETERS

Operational Temperature	-40°C~+85°C
Power Output Tolerance	0~3%
Maximum System Voltage	1500V
Maximum Series Fuse Rating	25A
Nominal Operating Cell Temperature	45±2°C
Protection Class	Class II
Fire Rating	IEC Class C

*The actual test value may be slightly deviated from the technical parameters due to the difference in test methods.

MECHANICAL LOADING

Front Side Maximum Static Loading	5400Pa
Rear Side Maximum Static Loading	2400Pa
Hailstone Test	25mm Hailstone at the speed of 23m/s

TEMPERATURE RATINGS (STC)

Temperature Coefficient of Isc	+0.04%/°C
Temperature Coefficient of Voc	-0.23%/°C
Temperature Coefficient of Pmax	-0.28%/°C



585~605 Watt

HORAY

TIER1
BloombergNEF

HS **182-144** TC Ocean N-type Mono-facial Modules

N-type
SMBB

SMBB Half-Cell Technology
More uniform current collection capability, reducing the current heat loss of the internal cells.

CONVERSION

Higher Output Power
The output power of 144 half-cells monocrystalline modules is up to 605W.

LOW LIGHT

Low Light Features
Higher performance under low light environment.

RESISTANT

Harsh Environmental Adaptability
Strict salt spray and ammonia corrosion test by the third party.

LID
LOW LID

N-type With Very Low LID
N-type solar cell has very low LID naturally which can reduce power degradation.

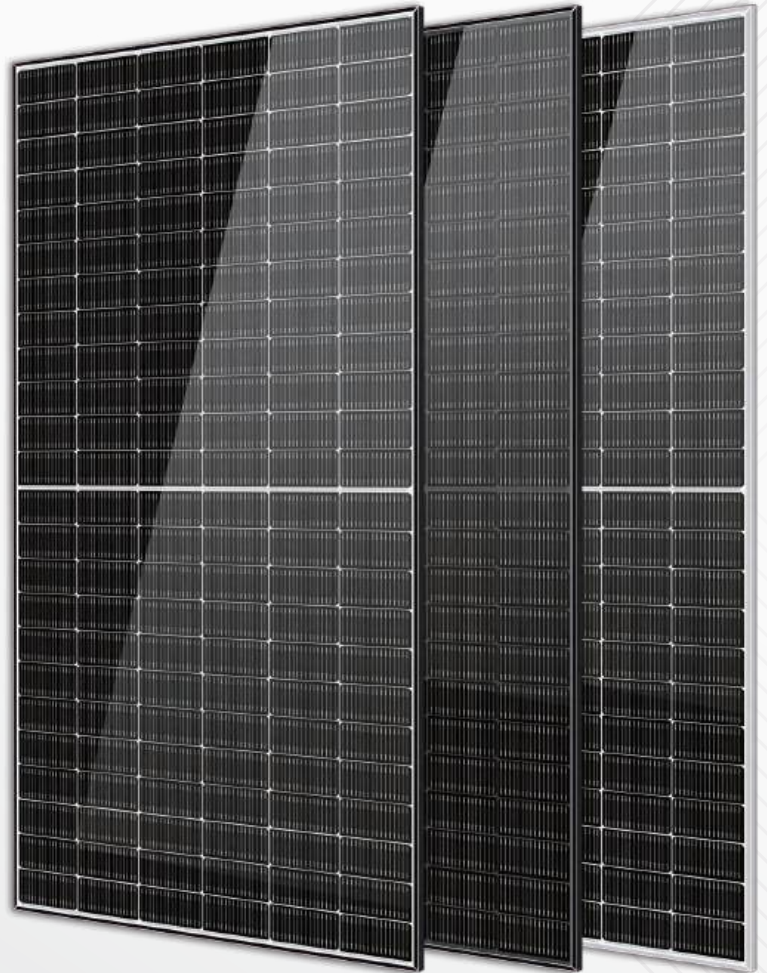

IEC61215:2021

IEC61730:2023

ISO9001:2015 Quality Management System

ISO14001:2015 Environmental Management System

ISO45001:2018 Occupational Health and Safety Management System

CE: Europe Standard

China Quality Certification Centre

Solar Product Certification

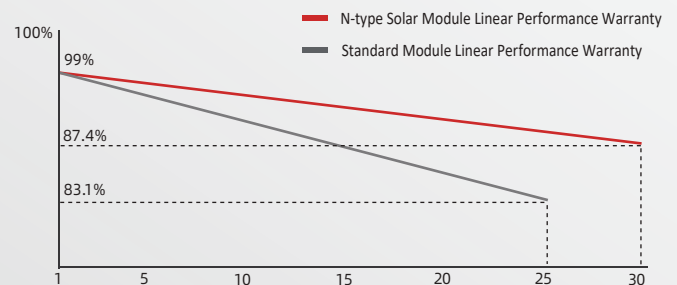

12

12-year product warranty

30

30-year linear power output warranty

HEADQUARTER: HORAY SOLAR CO., LTD.

GLOBAL MARKETING AND SERVICE: HORAY SOLAR GMBH

sales@horaysolar.com www.horaysolar.com +86-510 83580688

info@horaysolar.com www.horaysolar.com

No.300 Huiming Road, Huishan District, 214177 Wuxi, Jiangsu, P.R. China

Robert-Bosch-Straße 27-29, 63225 Langen, Germany

MECHANICAL DIAGRAMS

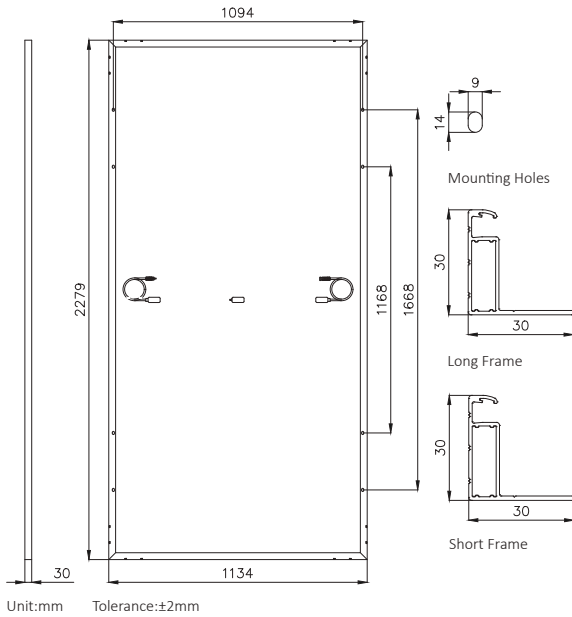

MECHANICAL PARAMETERS

Weight	26.0kg
Dimension	2279×1134×30mm
Cell Orientation	144 (6×24)
Junction Box	IP68, three diodes
Output Cable	4mm ² ,±300mm (length can be customized)
Connector	MC4 compatible
Glass	3.2mm AR coated heat strengthened glass
Frame	Anodized aluminum alloy frame
Packaging	37pcs per pallet/740pcs per 40'HC

MECHANICAL PARAMETERS

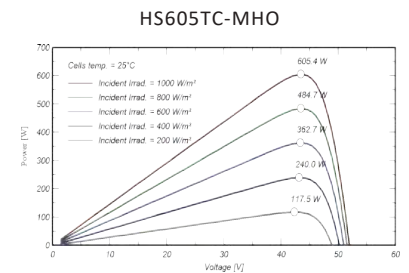
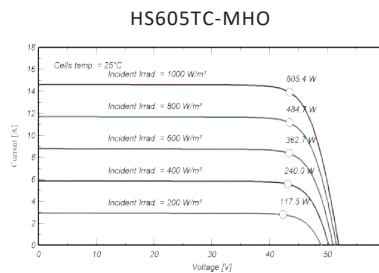

ELECTRICAL CHARACTERISTICS AT STC

Module Type	HS585TC-MHO	HS590TC-MHO	HS595TC-MHO	HS600TC-MHO	HS605TC-MHO
Testing Condition	STC	STC	STC	STC	STC
Maximum Power(Pmax/W)	585	590	595	600	605
Open Circuit Voltage(Voc/V)	51.52	51.63	51.74	51.85	51.95
Short Circuit Current(Isc/A)	14.30	14.38	14.46	14.54	14.62
Maximum Power Voltage(Vmp/V)	43.33	43.44	43.55	43.66	43.76
Maximum Power Current(Imp/A)	13.51	13.59	13.66	13.74	13.83
Module Efficiency(%)	22.6	22.8	23.0	23.2	23.4

* Under Standard Test Conditions (STC) of irradiance of 1000 W/m², spectrum AM 1.5 and cell temperature of 25°C.

ELECTRICAL CHARACTERISTICS AT NMOT

Module Type	HS585TC-MHO	HS590TC-MHO	HS595TC-MHO	HS600TC-MHO	HS605TC-MHO
Testing Condition	NMOT	NMOT	NMOT	NMOT	NMOT
Maximum Power(Pmax/W)	444	448	451	455	459
Open Circuit Voltage(Voc/V)	48.70	48.90	49.00	49.10	49.20
Short Circuit Current(Isc/A)	11.55	11.62	11.68	11.74	11.81
Maximum Power Voltage(Vmp/V)	40.50	40.70	40.80	40.90	41.00
Maximum Power Current(Imp/A)	10.94	11.00	11.05	11.12	11.20

* Under Nominal Module Operating Temperature (NMOT), irradiance of 800 W/m², spectrum AM 1.5, ambient temperature 20°C, wind speed 1 m/s.

OPERATING PARAMETERS

Operational Temperature	-40°C~+85°C
Power Output Tolerance	0~3%
Maximum System Voltage	1500V
Maximum Series Fuse Rating	25A
Nominal Operating Cell Temperature	45±2°C
Protection Class	Class II
Fire Rating	IEC Class C

*The actual test value may be slightly deviated from the technical parameters due to the difference in test methods.

MECHANICAL LOADING

Front Side Maximum Static Loading	5400Pa
Rear Side Maximum Static Loading	2400Pa
Hailstone Test	25mm Hailstone at the speed of 23m/s

TEMPERATURE RATINGS (STC)

Temperature Coefficient of Isc	+0.04%/°C
Temperature Coefficient of Voc	-0.23%/°C
Temperature Coefficient of Pmax	-0.28%/°C



Zertifikat

Certificate



Zertifikat Nr. Certificate No.
PV Horay Rights

Blatt Sheet
0003

Ihr Zeichen Client Reference
M.G

Unser Zeichen Our Reference 001-Ruanand-CN22NKK2
Ausstellungsdatum Date of Issue 002 11.08.2022 (day/mo/yr)

Genehmigungsinhaber License Holder
HORAY SOLAR CO., LTD
No.30-5,
Yanxin East Road, Huishan District
Wuxi,
214177 Jiangsu
P.R. China

Fertigungsstätte Manufacturing Plant
Refer to latest revision
of the annex list of factories

Prüfzeichen Test Mark



Geprüft nach Tested acc. to

IEC 61215
IEC 61730
Regular Production
Surveillance
www.tuv.com
ID 1111253582

IEC 61215-1:2021
IEC 61215-1-1:2021
IEC 61215-2:2021
IEC 61730-1:2016
IEC 61730-2:2016
EN IEC 61215-1:2021
EN IEC 61215-1-1:2021
EN IEC 61215-2:2021
EN IEC 61730-1:2018
EN IEC 61730-2:2018

Zertifiziertes Produkt (Geräteidentifikation)
Certified Product (Product Identification)

Lizenzentgelte - Einheit
License Fee - Unit

PV Module

Same as Page 0001-0002

In addition:

Type Designation:

Max. System Voltage: up to 1500 VDC (Voc at STC):

With cut of mono c-Si cell:

- HSxxx-MHG (xxx=170-180, in steps of 5, 36 cells)
- HSxxx-MHG (xxx=110-120, in steps of 5, 36 cells)
- HSxxx-MHG (xxx=80-90, in steps of 5, 36 cells)
- HSxxx-MHO (xxx=120-130, in steps of 5, 36 cells)
- HSxxx-MHO (xxx=80-90, in steps of 5, 36 cells)
- HSxxx-MHO (xxx=60-65, in steps of 5, 36 cells)
- HSxxx-MHL (xxx=100-110, in steps of 5, 36 cells)
- HSxxx-MHL (xxx=70-75, in steps of 5, 36 cells)
- HSxxx-MHL (xxx=50-55, in steps of 5, 36 cells)

Dem Zertifikat liegt unsere Prüf- und Zertifizierungsordnung zugrunde.
Das Produkt entspricht den o.g. Anforderungen, die Herstellung wird überwacht.
This certificate is based on our Testing and Certification Regulation. The product
fulfills above mentioned requirements, the production is subject to surveillance.

TÜV Rheinland LGA Products GmbH, Tillystraße 2, 90431 Nürnberg
http://www.tuv.com/safety E-mail: markcheck@tuv.com
Fax: +49 221 806-3935

Zertifizierungsstelle



Dipl.-Ing. Matthias Orzam

HORAY



HORAY

Customized & Non-Standard Expert

- +86-510-83580888
- sales@horaysolar.com
- www.horaysolar.com
- No.300 Huiming Road, Huishan District, Wuxi, Jiangsu, China



Official Website



Official Wechat Account



Official Video Account



Official Tik Tok Account

Solar Creek Mini Series

Non-Standard PV Module Collection

133/229



ABOUT HORAY SOLAR

HORAY SOLAR is a leading integrated photovoltaic company specializing in the research and development, production, and sales of solar cells, modules, and power systems. Our comprehensive product range includes high-quality solar cells and modules, among others.

Our state-of-the-art manufacturing facility is accredited with ISO9001, 45001, and 14001 certifications. We adhere to the highest standards of production and follow the international norms of IEC 61215 & IEC 61730 for the manufacture of HORAY SOLAR panels. Additionally, we offer OEM and ODM services to cater to the specific requirements of our customers. Our solar panels are certified with CE, TÜV and CQC, ensuring their compliance with various quality and safety standards.

Since its establishment, HORAY SOLAR has consistently prioritized product quality. Backed by strong technical support, professional production equipment, scientific production management, and stringent quality control, their products have achieved industry-leading standards. They have obtained numerous authoritative certifications both domestically and internationally, earning recognition and trust from a multitude of customers.

Looking ahead, HORAY SOLAR will persistently dedicate itself to the photovoltaic module industry, assuming the responsibility of promoting global green energy development. Together with global partners, we strive to create a better life for humanity and contribute to a greener home for every individual worldwide.

PRODUCT FEATURES



SMBB Technology

More uniform current collection capability, reducing the current heat loss of the internal cells.



Higher Output Power

The output power of monocrystalline modules is higher than normal modules.



Low Light Features

Higher performance under low light environment.



Harsh Environmental Adaptability

Strict salt spray and ammonia corrosion test by the third party.



With Very Low LID

Monocrystalline solar cell has very low LID which can reduce power degradation.



PID Protection

Ensure the attenuation probability caused by PID phenomenon is minimized.

CERTIFICATES



IEC 61215:2021
IEC 61730:2023



ISO 9001:2015
ISO 14001:2015
ISO 45001:2018



Europe Standard



China Quality Certification Centre

APPLICATION



POWER FOR RVS



POWER FOR LIGHTS



POWER FOR CAMPING



POWER FOR CARPORT

CUSTOMIZATION

We offer complete customization of solar panels to meet the unique demands of your application.

Size & Shape: Specify exact dimensions, or request unique shapes to fit constrained or innovative designs.

Power Output: We can tailor the cell configuration to achieve your precise power requirements.

Electrical Parameters: Customize electrical characteristics to perfectly match your system.

Durability & Aesthetics: Choose from various frame finishes, backsheet colors, junction box and so on.

HS 1/10G1-36 *Mini*

20W

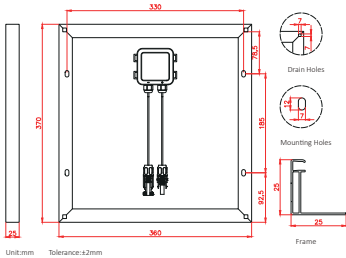
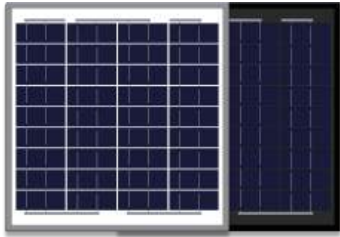

Dimension	370×360×25mm
Cell Orientation	36 (4x9)
Weight	2.0kg
Junction Box	IP67
Output Cable	1.5mm ² , length can be customized
Connector	MC4 compatible
Glass	3.2mm AR coated tempered glass
Frame	Anodized aluminum alloy frame
Operational Temperature	-40°C~+85°C
Power Output Tolerance	0~3%
Maximum System Voltage	1000V
Maximum Series Fuse Rating	10A
Nominal Operating Cell Temperature	45±2°C
Fire Rating	IEC Class C

CERTIFICATES

IEC 61215:2021 / IEC61730:2023

ISO9001:2015 / ISO14001:2015 / ISO45001:2018

Europe Standard / China Quality Certification Centre



10 10-year product warranty

25 25-year power output warranty

Module Type	HM20-MHL
Testing Condition	STC
Maximum Power(Pmax/W)	20
Open Circuit Voltage(Voc/V)	25.21
Short Circuit Current(Isc/A)	1.01
Maximum Power Current(Vmp/V)	20.95
Maximum Power Current(Imp/A)	0.95
Module Efficiency(%)	15.0
Temperature Coefficient of Isc	+0.05%/°C
Temperature Coefficient of Voc	-0.28%/°C
Temperature Coefficient of Pmax	-0.34%/°C
* Under Standard Test Conditions (STC) of irradiance of 1000 W/m ² , spectrum AM 1.5 and cell temperature of 25°C.	

CAUTION: READ SAFETY AND INSTALLATION INSTRUCTIONS BEFORE USING THE PRODUCT.
©2025 Horay Solar Co., Ltd. All rights reserved.
Specifications included in this datasheet are subject to change without notice.

HORAY | TIER1 BloombergNEF

HS 1/6G1-36 *Mini*

30W

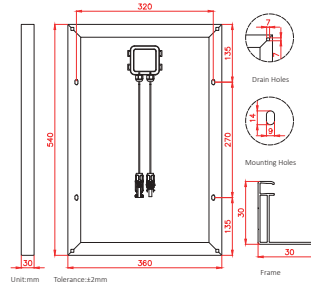

Dimension	540×360×30mm
Cell Orientation	36 (4x9)
Weight	2.5kg
Junction Box	IP67
Output Cable	1.5mm ² , length can be customized
Connector	MC4 compatible
Glass	3.2mm AR coated tempered glass
Frame	Anodized aluminum alloy frame
Operational Temperature	-40°C~+85°C
Power Output Tolerance	0~3%
Maximum System Voltage	1000V
Maximum Series Fuse Rating	10A
Nominal Operating Cell Temperature	45±2°C
Fire Rating	IEC Class C

CERTIFICATES

IEC 61215:2021 / IEC61730:2023

ISO9001:2015 / ISO14001:2015 / ISO45001:2018

Europe Standard / China Quality Certification Centre



10 10-year product warranty

25 25-year power output warranty

Module Type	HM30-MHL
Testing Condition	STC
Maximum Power(Pmax/W)	30
Open Circuit Voltage(Voc/V)	24.26
Short Circuit Current(Isc/A)	1.57
Maximum Power Current(Vmp/V)	20.16
Maximum Power Current(Imp/A)	1.49
Module Efficiency(%)	15.4
Temperature Coefficient of Isc	+0.05%/°C
Temperature Coefficient of Voc	-0.28%/°C
Temperature Coefficient of Pmax	-0.34%/°C
* Under Standard Test Conditions (STC) of irradiance of 1000 W/m ² , spectrum AM 1.5 and cell temperature of 25°C.	

CAUTION: READ SAFETY AND INSTALLATION INSTRUCTIONS BEFORE USING THE PRODUCT.
©2025 Horay Solar Co., Ltd. All rights reserved.
Specifications included in this datasheet are subject to change without notice.

HS 1/5G1-36 Mini

40W

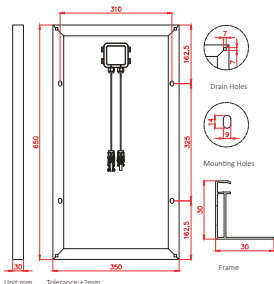
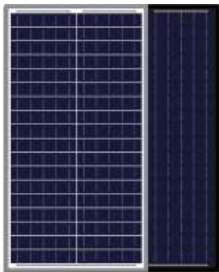

Dimension	650×350×30mm
Cell Orientation	36 (2×18)
Weight	3.0kg
Junction Box	IP67
Output Cable	1.5mm ² , length can be customized
Connector	MC4 compatible
Glass	3.2mm AR coated tempered glass
Frame	Anodized aluminum alloy frame
Operational Temperature	-40°C~+85°C
Power Output Tolerance	0~3%
Maximum System Voltage	1000V
Maximum Series Fuse Rating	10A
Nominal Operating Cell Temperature	45±2°C
Fire Rating	IEC Class C

CERTIFICATES

IEC 61215:2021 / IEC61730:2023

ISO9001:2015 / ISO14001:2015 / ISO45001:2018

Europe Standard / China Quality Certification Centre



10-year product warranty



25-year power output warranty

Module Type	HM40-MHL
Testing Condition	STC
Maximum Power(Pmax/W)	40
Open Circuit Voltage(Voc/V)	25.21
Short Circuit Current(Isc/A)	2.02
Maximum Power Voltage(Vmp/V)	20.95
Maximum Power Current(Imp/A)	1.91
Module Efficiency(%)	17.6
Temperature Coefficient of Isc	+0.05%/°C
Temperature Coefficient of Voc	-0.28%/°C
Temperature Coefficient of Pmax	-0.34%/°C
* Under Standard Test Conditions (STC) of irradiance of 1000 W/m ² , spectrum AM 1.5 and cell temperature of 25°C.	

CAUTION: READ SAFETY AND INSTALLATION INSTRUCTIONS BEFORE USING THE PRODUCT.
©2025 Horay Solar Co., Ltd. All rights reserved.
Specifications included in this datasheet are subject to change without notice.

HS 1/6M10-36 TC Mini

45W / 50W

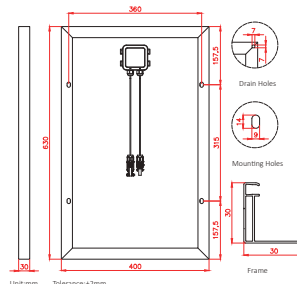

Dimension	630×400×30mm
Cell Orientation	36 (2×18)
Weight	4.0kg
Junction Box	IP67
Output Cable	1.5mm ² , length can be customized
Connector	MC4 compatible
Glass	3.2mm AR coated tempered glass
Frame	Anodized aluminum alloy frame
Operational Temperature	-40°C~+85°C
Power Output Tolerance	0~3%
Maximum System Voltage	1000V
Maximum Series Fuse Rating	10A
Nominal Operating Cell Temperature	45±2°C
Fire Rating	IEC Class C

CERTIFICATES

IEC 61215:2021 / IEC61730:2023

ISO9001:2015 / ISO14001:2015 / ISO45001:2018

Europe Standard / China Quality Certification Centre



10-year product warranty



25-year power output warranty

Module Type	HM45TC-MHO	HM50TC-MHO
Testing Condition	STC	STC
Maximum Power(Pmax/W)	45	50
Open Circuit Voltage(Voc/V)	26.86	27.68
Short Circuit Current(Isc/A)	2.13	2.30
Maximum Power Voltage(Vmp/V)	22.32	23.00
Maximum Power Current(Imp/A)	2.02	2.17
Module Efficiency(%)	17.9	19.8
Temperature Coefficient of Isc		+0.04%/°C
Temperature Coefficient of Voc		-0.23%/°C
Temperature Coefficient of Pmax		-0.28%/°C
* Under Standard Test Conditions (STC) of irradiance of 1000 W/m ² , spectrum AM 1.5 and cell temperature of 25°C.		

CAUTION: READ SAFETY AND INSTALLATION INSTRUCTIONS BEFORE USING THE PRODUCT.
©2025 Horay Solar Co., Ltd. All rights reserved.
Specifications included in this datasheet are subject to change without notice.

HS 1/4M10-36 TC Mini

70W / 75W



Dimension	620x585x30mm
Cell Orientation	36 (3x12)
Weight	4.5kg
Junction Box	IP67
Output Cable	1.5mm ² , length can be customized
Connector	MC4 compatible
Glass	3.2mm AR coated tempered glass
Frame	Anodized aluminum alloy frame
Operational Temperature	-40°C~+85°C
Power Output Tolerance	0~3%
Maximum System Voltage	1000V
Maximum Series Fuse Rating	10A
Nominal Operating Cell Temperature	45±2°C
Fire Rating	IEC Class C

CERTIFICATES

IEC 61215:2021 / IEC61730:2023

ISO9001:2015 / ISO14001:2015 / ISO45001:2018

Europe Standard / China Quality Certification Centre

10 10-year product warranty

25 25-year power output warranty

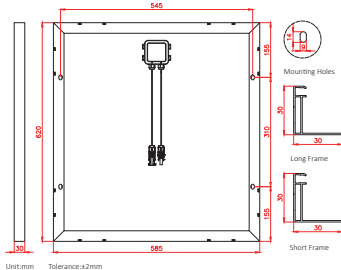

Module Type	HM70TC-MHO	HM75TC-MHO
Testing Condition	STC	STC
Maximum Power(Pmax/W)	70	75
Open Circuit Voltage(Voc/V)	27.03	27.90
Short Circuit Current(Isc/A)	3.29	3.42
Maximum Power Voltage(Vmp/V)	22.46	23.18
Maximum Power Current(Imp/A)	3.12	3.23
Module Efficiency(%)	19.3	20.7
Temperature Coefficient of Isc		+0.04%/°C
Temperature Coefficient of Voc		-0.23%/°C
Temperature Coefficient of Pmax		-0.28%/°C
* Under Standard Test Conditions (STC) of irradiance of 1000 W/m ² , spectrum AM 1.5 and cell temperature of 25°C.		

CAUTION: READ SAFETY AND INSTALLATION INSTRUCTIONS BEFORE USING THE PRODUCT.
©2025 Horay Solar Co.,Ltd. All rights reserved.
Specifications included in this datasheet are subject to change without notice.

HORAY | TIER1



HS 1/3M10-36 TC Mini

90W / 95W / 100W



Dimension	620x770x30mm
Cell Orientation	36 (4x9)
Weight	5.5kg
Junction Box	IP68
Output Cable	4mm ² , length can be customized
Connector	MC4 compatible
Glass	3.2mm AR coated tempered glass
Frame	Anodized aluminum alloy frame
Operational Temperature	-40°C~+85°C
Power Output Tolerance	0~3%
Maximum System Voltage	1500V
Maximum Series Fuse Rating	20A
Nominal Operating Cell Temperature	45±2°C
Fire Rating	IEC Class C

CERTIFICATES

IEC 61215:2021 / IEC61730:2023

ISO9001:2015 / ISO14001:2015 / ISO45001:2018

Europe Standard / China Quality Certification Centre

10 10-year product warranty

25 25-year power output warranty

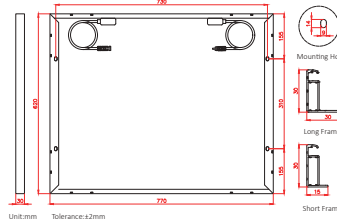

Module Type	HM90TC-MHO	HM95TC-MHO	HM100TC-MHO
Testing Condition	STC	STC	STC
Maximum Power(Pmax/W)	90	95	100
Open Circuit Voltage(Voc/V)	26.86	27.29	27.72
Short Circuit Current(Isc/A)	4.26	4.42	4.58
Maximum Power Voltage(Vmp/V)	22.32	22.68	23.04
Maximum Power Current(Imp/A)	4.03	4.19	4.34
Module Efficiency(%)	18.9	19.9	20.9
Temperature Coefficient of Isc		+0.04%/°C	
Temperature Coefficient of Voc		-0.23%/°C	
Temperature Coefficient of Pmax		-0.28%/°C	
* Under Standard Test Conditions (STC) of irradiance of 1000 W/m ² , spectrum AM 1.5 and cell temperature of 25°C.			

CAUTION: READ SAFETY AND INSTALLATION INSTRUCTIONS BEFORE USING THE PRODUCT.
©2025 Horay Solar Co.,Ltd. All rights reserved.
Specifications included in this datasheet are subject to change without notice.

HS 1/2M10-36 TC Mini

140W / 145W / 150W



Dimension	900×770×30mm
Cell Orientation	36 (4x9)
Weight	8.5kg
Junction Box	IP68
Output Cable	4mm ² , length can be customized
Connector	MC4 compatible
Glass	3.2mm AR coated tempered glass
Frame	Anodized aluminum alloy frame
Operational Temperature	-40°C~+85°C
Power Output Tolerance	0~3%
Maximum System Voltage	1500V
Maximum Series Fuse Rating	20A
Nominal Operating Cell Temperature	45±2°C
Fire Rating	IEC Class C

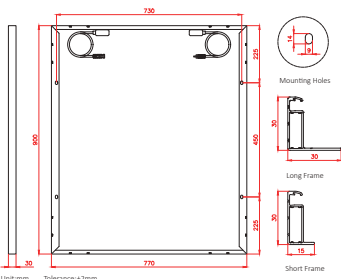

CERTIFICATES

IEC 61215:2021 / IEC61730:2023

ISO9001:2015 / ISO14001:2015 / ISO45001:2018

Europe Standard / China Quality Certification Centre



10 10-year product warranty **25** 25-year power output warranty

Module Type	HM140TC-MHO	HM145TC-MHO	HM150TC-MHO
Testing Condition	STC	STC	STC
Maximum Power(Pmax/W)	140	145	150
Open Circuit Voltage(Voc/V)	27.03	27.64	27.90
Short Circuit Current(Isc/A)	6.58	6.67	6.83
Maximum Power Voltage(Vmp/V)	22.46	22.97	23.18
Maximum Power Current(Imp/A)	6.23	6.31	6.47
Module Efficiency(%)	20.2	20.9	21.6
Temperature Coefficient of Isc		+0.04%/°C	
Temperature Coefficient of Voc		-0.23%/°C	
Temperature Coefficient of Pmax		-0.28%/°C	
* Under Standard Test Conditions (STC) of irradiance of 1000 W/m ² , spectrum AM 1.5 and cell temperature of 25°C.			

HS 1/2M10-72 TC Mini

280W / 285W / 290W / 295W / 300W

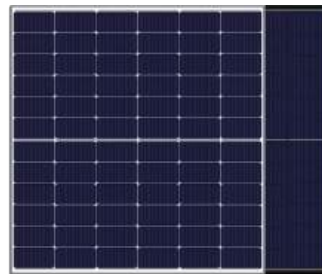

Dimension	1190×1134×30mm
Cell Orientation	72 (6×12)
Weight	15.5kg
Junction Box	IP68
Output Cable	4mm ² , length can be customized
Connector	MC4 compatible
Glass	3.2mm AR coated tempered glass
Frame	Anodized aluminum alloy frame
Operational Temperature	-40°C~+85°C
Power Output Tolerance	0~3%
Maximum System Voltage	1500V
Maximum Series Fuse Rating	20A
Nominal Operating Cell Temperature	45±2°C
Fire Rating	IEC Class C

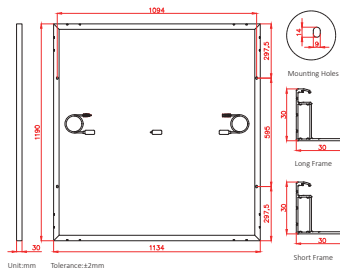

CERTIFICATES

IEC 61215:2021 / IEC61730:2023

ISO9001:2015 / ISO14001:2015 / ISO45001:2018

Europe Standard / China Quality Certification Centre



10 10-year product warranty **25** 25-year power output warranty

Module Type	HM280TC-MHO	HM285TC-MHO	HM290TC-MHO	HM295TC-MHO	HM300TC-MHO
Testing Condition	STC	STC	STC	STC	STC
Maximum Power(Pmax/W)	280	285	290	295	300
Open Circuit Voltage(Voc/V)	26.86	27.16	27.46	27.68	27.90
Short Circuit Current(Isc/A)	13.25	13.33	13.42	13.54	13.67
Maximum Power Voltage(Vmp/V)	22.32	22.57	22.82	23.00	23.18
Maximum Power Current(Imp/A)	12.54	12.63	12.71	12.82	12.94
Module Efficiency(%)	20.7	21.1	21.5	21.9	22.2
Temperature Coefficient of Isc			+0.04%/°C		
Temperature Coefficient of Voc			-0.23%/°C		
Temperature Coefficient of Pmax			-0.28%/°C		
* Under Standard Test Conditions (STC) of irradiance of 1000 W/m ² , spectrum AM 1.5 and cell temperature of 25°C.					

CAUTION: READ SAFETY AND INSTALLATION INSTRUCTIONS BEFORE USING THE PRODUCT.
©2025 Horay Solar Co., Ltd. All rights reserved.
Specifications included in this datasheet are subject to change without notice.

CAUTION: READ SAFETY AND INSTALLATION INSTRUCTIONS BEFORE USING THE PRODUCT.
©2025 Horay Solar Co., Ltd. All rights reserved.
Specifications included in this datasheet are subject to change without notice.

HS 1/6G12R-36 TC *Mini*

50W / 55W

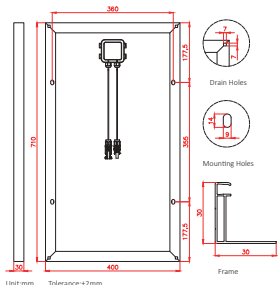

Dimension	710x400x30mm
Cell Orientation	36 (2x18)
Weight	4.0kg
Junction Box	IP67
Output Cable	1.5mm ² , length can be customized
Connector	MC4 compatible
Glass	3.2mm AR coated tempered glass
Frame	Anodized aluminum alloy frame
Operational Temperature	-40°C~+85°C
Power Output Tolerance	0~3%
Maximum System Voltage	1000V
Maximum Series Fuse Rating	10A
Nominal Operating Cell Temperature	45±2°C
Fire Rating	IEC Class C

CERTIFICATES

IEC 61215:2021 / IEC61730:2023

ISO9001:2015 / ISO14001:2015 / ISO45001:2018

Europe Standard / China Quality Certification Centre



10-year product warranty



25-year power output warranty

HORAY | TIER1 BloombergNEF

HS 1/4G12R-36 TC *Mini*

80W / 85W

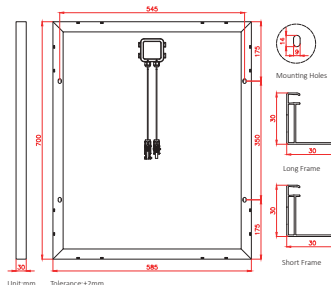

Dimension	700x585x30mm
Cell Orientation	36 (3x12)
Weight	5.0kg
Junction Box	IP67
Output Cable	1.5mm ² , length can be customized
Connector	MC4 compatible
Glass	3.2mm AR coated tempered glass
Frame	Anodized aluminum alloy frame
Operational Temperature	-40°C~+85°C
Power Output Tolerance	0~3%
Maximum System Voltage	1000V
Maximum Series Fuse Rating	10A
Nominal Operating Cell Temperature	45±2°C
Fire Rating	IEC Class C

CERTIFICATES

IEC 61215:2021 / IEC61730:2023

ISO9001:2015 / ISO14001:2015 / ISO45001:2018

Europe Standard / China Quality Certification Centre



10-year product warranty



25-year power output warranty

Module Type	HM50TC-MHC	HM55TC-MHC
Testing Condition	STC	STC
Maximum Power(Pmax/W)	50	55
Open Circuit Voltage(Voc/V)	26.64	27.42
Short Circuit Current(Isc/A)	2.39	2.55
Maximum Power Voltage(Vmp/V)	22.14	22.79
Maximum Power Current(Imp/A)	2.26	2.41
Module Efficiency(%)	17.6	19.4
Temperature Coefficient of Isc		+0.04%/°C
Temperature Coefficient of Voc		-0.23%/°C
Temperature Coefficient of Pmax		-0.28%/°C
* Under Standard Test Conditions (STC) of irradiance of 1000 W/m ² , spectrum AM 1.5 and cell temperature of 25°C.		

Module Type	HM80TC-MHC	HM85TC-MHC
Testing Condition	STC	STC
Maximum Power(Pmax/W)	80	85
Open Circuit Voltage(Voc/V)	26.77	27.90
Short Circuit Current(Isc/A)	3.80	3.87
Maximum Power Voltage(Vmp/V)	22.25	23.18
Maximum Power Current(Imp/A)	3.60	3.67
Module Efficiency(%)	19.5	20.8
Temperature Coefficient of Isc		+0.04%/°C
Temperature Coefficient of Voc		-0.23%/°C
Temperature Coefficient of Pmax		-0.28%/°C
* Under Standard Test Conditions (STC) of irradiance of 1000 W/m ² , spectrum AM 1.5 and cell temperature of 25°C.		

CAUTION: READ SAFETY AND INSTALLATION INSTRUCTIONS BEFORE USING THE PRODUCT.
©2025 Horay Solar Co., Ltd. All rights reserved.
Specifications included in this datasheet are subject to change without notice.

CAUTION: READ SAFETY AND INSTALLATION INSTRUCTIONS BEFORE USING THE PRODUCT.
©2025 Horay Solar Co., Ltd. All rights reserved.
Specifications included in this datasheet are subject to change without notice.

HS 1/3G12R-36 TC *Mini*

105W / 110W / 115W



Dimension	910x585x30mm
Cell Orientation	36 (3x12)
Weight	6.0kg
Junction Box	IP67
Output Cable	1.5mm ² , length can be customized
Connector	MC4 compatible
Glass	3.2mm AR coated tempered glass
Frame	Anodized aluminum alloy frame
Operational Temperature	-40°C~+85°C
Power Output Tolerance	0~3%
Maximum System Voltage	1000V
Maximum Series Fuse Rating	10A
Nominal Operating Cell Temperature	45±2°C
Fire Rating	IEC Class C

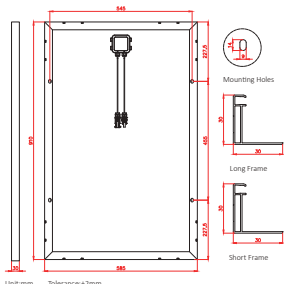

CERTIFICATES

IEC 61215:2021 / IEC61730:2023

ISO9001:2015 / ISO14001:2015 / ISO45001:2018

Europe Standard / China Quality Certification Centre

10 10-year product warranty

25 25-year power output warranty

Module Type	HM105TC-MHC	HM110TC-MHC	HM115TC-MHC
Testing Condition	STC	STC	STC
Maximum Power(Pmax/W)	105	110	115
Open Circuit Voltage(Voc/V)	26.77	27.42	27.90
Short Circuit Current(Isc/A)	4.98	5.10	5.24
Maximum Power Voltage(Vmp/V)	22.25	22.79	23.18
Maximum Power Current(Imp/A)	4.72	4.83	4.96
Module Efficiency(%)	19.7	20.7	21.6
Temperature Coefficient of Isc		+0.04%/°C	
Temperature Coefficient of Voc		-0.23%/°C	
Temperature Coefficient of Pmax		-0.28%/°C	
* Under Standard Test Conditions (STC) of irradiance of 1000 W/m ² , spectrum AM 1.5 and cell temperature of 25°C.			

CAUTION: READ SAFETY AND INSTALLATION INSTRUCTIONS BEFORE USING THE PRODUCT.
©2025 Horay Solar Co., Ltd. All rights reserved.
Specifications included in this datasheet are subject to change without notice.

HORAY | TIER1 BloombergNEF

HS 1/2G12R-36 TC *Mini*

160W / 165W / 170W



Dimension	1020x770x30mm
Cell Orientation	36 (4x9)
Weight	8.5kg
Junction Box	IP68
Output Cable	4mm ² , length can be customized
Connector	MC4 compatible
Glass	3.2mm AR coated tempered glass
Frame	Anodized aluminum alloy frame
Operational Temperature	-40°C~+85°C
Power Output Tolerance	0~3%
Maximum System Voltage	1500V
Maximum Series Fuse Rating	20A
Nominal Operating Cell Temperature	45±2°C
Fire Rating	IEC Class C

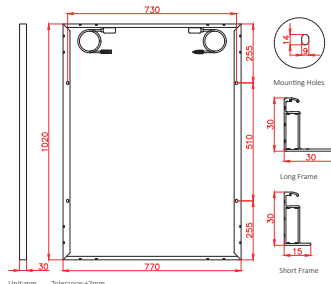

CERTIFICATES

IEC 61215:2021 / IEC61730:2023

ISO9001:2015 / ISO14001:2015 / ISO45001:2018

Europe Standard / China Quality Certification Centre

10 10-year product warranty

25 25-year power output warranty

Module Type	HM160TC-MHC	HM165TC-MHC	HM170TC-MHC
Testing Condition	STC	STC	STC
Maximum Power(Pmax/W)	160	165	170
Open Circuit Voltage(Voc/V)	26.77	27.42	27.90
Short Circuit Current(Isc/A)	7.60	7.65	7.74
Maximum Power Voltage(Vmp/V)	22.25	22.79	23.18
Maximum Power Current(Imp/A)	7.19	7.24	7.33
Module Efficiency(%)	20.4	21.0	21.6
Temperature Coefficient of Isc		+0.04%/°C	
Temperature Coefficient of Voc		-0.23%/°C	
Temperature Coefficient of Pmax		-0.28%/°C	
* Under Standard Test Conditions (STC) of irradiance of 1000 W/m ² , spectrum AM 1.5 and cell temperature of 25°C.			

CAUTION: READ SAFETY AND INSTALLATION INSTRUCTIONS BEFORE USING THE PRODUCT.
©2025 Horay Solar Co., Ltd. All rights reserved.
Specifications included in this datasheet are subject to change without notice.

HS 1/2G12R-72 TC *Mini*



320W / 325W / 330W / 335W / 340W

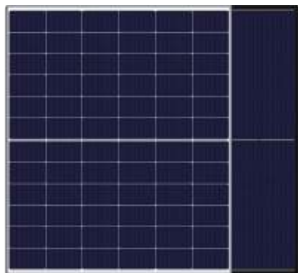

Dimension	1350x1134x30mm
Cell Orientation	72 (6x12)
Weight	15.5kg
Junction Box	IP68
Output Cable	4mm ² , length can be customized
Connector	MC4 compatible
Glass	3.2mm AR coated tempered glass
Frame	Anodized aluminum alloy frame
Operational Temperature	-40°C~+85°C
Power Output Tolerance	0~3%
Maximum System Voltage	1500V
Maximum Series Fuse Rating	20A
Nominal Operating Cell Temperature	45±2°C
Fire Rating	IEC Class C

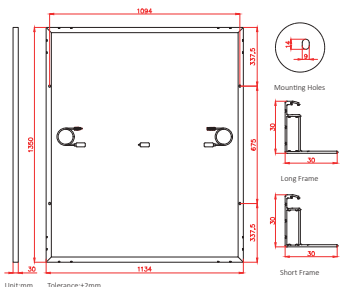

Unit:mm Tolerance:±2mm

CERTIFICATES

IEC 61215:2021 / IEC61730:2023

ISO9001:2015 / ISO14001:2015 / ISO45001:2018

Europe Standard / China Quality Certification Centre



10 10-year product warranty

25 25-year power output warranty

Module Type	HM320TC-MHC	HM325TC-MHC	HM330TC-MHC	HM335TC-MHC	HM340TC-MHC
Testing Condition	STC	STC	STC	STC	STC
Maximum Power (Pmax/W)	320	325	330	335	340
Open Circuit Voltage(Voc/V)	26.64	26.86	27.12	27.51	27.90
Short Circuit Current(Isc/A)	15.26	15.38	15.46	15.48	15.49
Maximum Power Voltage(Vmp/V)	22.14	22.32	22.54	22.86	23.18
Maximum Power Current(Imp/A)	14.45	14.56	14.64	14.65	14.67
Module Efficiency(%)	20.9	21.2	21.6	21.9	22.2
Temperature Coefficient of Isc			+0.04%/°C		
Temperature Coefficient of Voc			-0.23%/°C		
Temperature Coefficient of Pmax			-0.28%/°C		
* Under Standard Test Conditions (STC) of irradiance of 1000 W/m ² , spectrum AM 1.5 and cell temperature of 25°C.					

CAUTION: READ SAFETY AND INSTALLATION INSTRUCTIONS BEFORE USING THE PRODUCT.
©2025 Horay Solar Co., Ltd. All rights reserved.
Specifications included in this datasheet are subject to change without notice.

HS 1/6G12-36 TC *Mini*



60W / 65W



Dimension	710x455x30mm
Cell Orientation	36 (2x18)
Weight	4.0kg
Junction Box	IP67
Output Cable	1.5mm ² , length can be customized
Connector	MC4 compatible
Glass	3.2mm AR coated tempered glass
Frame	Anodized aluminum alloy frame
Operational Temperature	-40°C~+85°C
Power Output Tolerance	0~3%
Maximum System Voltage	1000V
Maximum Series Fuse Rating	10A
Nominal Operating Cell Temperature	45±2°C
Fire Rating	IEC Class C

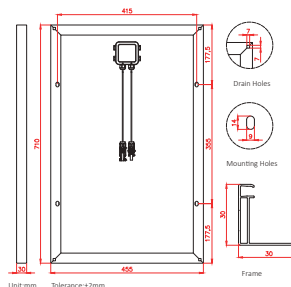

Unit:mm Tolerance:±2mm

CERTIFICATES

IEC 61215:2021 / IEC61730:2023

ISO9001:2015 / ISO14001:2015 / ISO45001:2018

Europe Standard / China Quality Certification Centre



10 10-year product warranty

25 25-year power output warranty

Module Type	HM60TC-MHG	HM65TC-MHG
Testing Condition	STC	STC
Maximum Power (Pmax/W)	60	65
Open Circuit Voltage(Voc/V)	26.64	27.29
Short Circuit Current(Isc/A)	2.86	3.03
Maximum Power Voltage(Vmp/V)	22.14	22.68
Maximum Power Current(Imp/A)	2.71	2.87
Module Efficiency(%)	18.6	20.1
Temperature Coefficient of Isc		+0.04%/°C
Temperature Coefficient of Voc		-0.23%/°C
Temperature Coefficient of Pmax		-0.28%/°C
* Under Standard Test Conditions (STC) of irradiance of 1000 W/m ² , spectrum AM 1.5 and cell temperature of 25°C.		

CAUTION: READ SAFETY AND INSTALLATION INSTRUCTIONS BEFORE USING THE PRODUCT.
©2025 Horay Solar Co., Ltd. All rights reserved.
Specifications included in this datasheet are subject to change without notice.

HS 1/4G12-36 TC Mini

90W / 95W / 100W

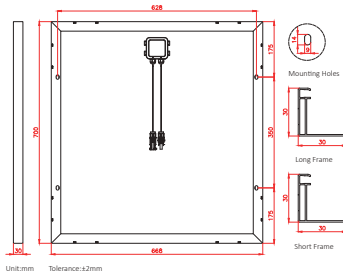

Dimension	700×668×30mm
Cell Orientation	36 (3×12)
Weight	5.5kg
Junction Box	IP67
Output Cable	1.5mm ² , length can be customized
Connector	MC4 compatible
Glass	3.2mm AR coated tempered glass
Frame	Anodized aluminum alloy frame
Operational Temperature	-40°C~+85°C
Power Output Tolerance	0~3%
Maximum System Voltage	1000V
Maximum Series Fuse Rating	10A
Nominal Operating Cell Temperature	45±2°C
Fire Rating	IEC Class C

CERTIFICATES

IEC 61215:2021 / IEC61730:2023

ISO9001:2015 / ISO14001:2015 / ISO45001:2018

Europe Standard / China Quality Certification Centre



Module Type	HM90TC-MHG	HM95TC-MHG	HM100TC-MHG
Testing Condition	STC	STC	STC
Maximum Power(Pmax/W)	90	95	100
Open Circuit Voltage(Voc/V)	26.64	27.07	27.29
Short Circuit Current(Isc/A)	4.29	4.46	4.66
Maximum Power Voltage(Vmp/V)	22.14	22.50	22.68
Maximum Power Current(Imp/A)	4.07	4.22	4.41
Module Efficiency(%)	19.2	20.3	21.4
Temperature Coefficient of Isc		+0.04%/°C	
Temperature Coefficient of Voc		-0.23%/°C	
Temperature Coefficient of Pmax		-0.28%/°C	
* Under Standard Test Conditions (STC) of irradiance of 1000 W/m ² , spectrum AM 1.5 and cell temperature of 25°C.			

CAUTION: READ SAFETY AND INSTALLATION INSTRUCTIONS BEFORE USING THE PRODUCT.
©2025 Horay Solar Co., Ltd. All rights reserved.
Specifications included in this datasheet are subject to change without notice.

HORAY | TIER1



HS 1/3G12-36 TC Mini

120W / 125W / 130W

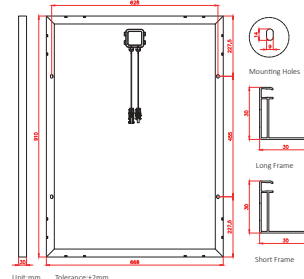

Dimension	910×668×30mm
Cell Orientation	36 (3×12)
Weight	7.0kg
Junction Box	IP67
Output Cable	1.5mm ² , length can be customized
Connector	MC4 compatible
Glass	3.2mm AR coated tempered glass
Frame	Anodized aluminum alloy frame
Operational Temperature	-40°C~+85°C
Power Output Tolerance	0~3%
Maximum System Voltage	1000V
Maximum Series Fuse Rating	10A
Nominal Operating Cell Temperature	45±2°C
Fire Rating	IEC Class C

CERTIFICATES

IEC 61215:2021 / IEC61730:2023

ISO9001:2015 / ISO14001:2015 / ISO45001:2018

Europe Standard / China Quality Certification Centre



Module Type	HM120TC-MHG	HM125TC-MHG	HM130TC-MHG
Testing Condition	STC	STC	STC
Maximum Power(Pmax/W)	120	125	130
Open Circuit Voltage(Voc/V)	26.64	26.99	27.29
Short Circuit Current(Isc/A)	5.72	5.89	6.05
Maximum Power Voltage(Vmp/V)	22.14	22.43	22.68
Maximum Power Current(Imp/A)	5.42	5.57	5.73
Module Efficiency(%)	19.7	20.6	21.4
Temperature Coefficient of Isc		+0.04%/°C	
Temperature Coefficient of Voc		-0.23%/°C	
Temperature Coefficient of Pmax		-0.28%/°C	
* Under Standard Test Conditions (STC) of irradiance of 1000 W/m ² , spectrum AM 1.5 and cell temperature of 25°C.			

CAUTION: READ SAFETY AND INSTALLATION INSTRUCTIONS BEFORE USING THE PRODUCT.
©2025 Horay Solar Co., Ltd. All rights reserved.
Specifications included in this datasheet are subject to change without notice.

HS 1/2G12-36 TC Mini

185W / 190W / 195W / 200W

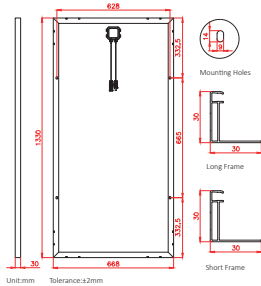

Dimension	1330×668×30mm
Cell Orientation	36 (3×12)
Weight	10.0kg
Junction Box	IP67
Output Cable	2.5mm ² , length can be customized
Connector	MC4 compatible
Glass	3.2mm AR coated tempered glass
Frame	Anodized aluminum alloy frame
Operational Temperature	-40°C~+85°C
Power Output Tolerance	0~3%
Maximum System Voltage	1000V
Maximum Series Fuse Rating	15A
Nominal Operating Cell Temperature	45±2°C
Fire Rating	IEC Class C

CERTIFICATES

IEC 61215:2021 / IEC61730:2023

ISO9001:2015 / ISO14001:2015 / ISO45001:2018

Europe Standard / China Quality Certification Centre



10-year product warranty



25-year power output warranty

Module Type	HM185TC-MHG	HM190TC-MHG	HM195TC-MHG	HM200TC-MHG
Testing Condition	STC	STC	STC	STC
Maximum Power(Pmax/W)	185	190	195	200
Open Circuit Voltage(Voc/V)	26.64	27.03	27.29	27.38
Short Circuit Current(Isc/A)	8.82	8.93	9.08	9.11
Maximum Power Voltage(Vmp/V)	22.14	22.46	22.68	22.72
Maximum Power Current(Imp/A)	8.36	8.46	8.60	8.80
Module Efficiency(%)	20.8	21.4	22.0	22.5
Temperature Coefficient of Isc		+0.04%/°C		
Temperature Coefficient of Voc		-0.23%/°C		
Temperature Coefficient of Pmax		-0.28%/°C		
* Under Standard Test Conditions (STC) of irradiance of 1000 W/m ² , spectrum AM 1.5 and cell temperature of 25°C.				

CAUTION: READ SAFETY AND INSTALLATION INSTRUCTIONS BEFORE USING THE PRODUCT.
©2025 Horay Solar Co., Ltd. All rights reserved.
Specifications included in this datasheet are subject to change without notice.

HS 1/2G12-60 TC Mini

300W / 305W / 310W / 315W / 320W

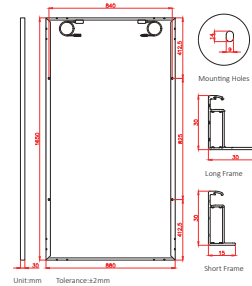
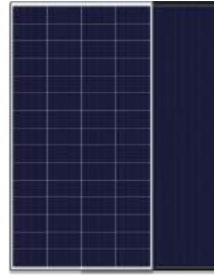

Dimension	1650×880×30mm
Cell Orientation	60 (4×15)
Weight	15.0kg
Junction Box	IP68
Output Cable	4mm ² , length can be customized
Connector	MC4 compatible
Glass	3.2mm AR coated tempered glass
Frame	Anodized aluminum alloy frame
Operational Temperature	-40°C~+85°C
Power Output Tolerance	0~3%
Maximum System Voltage	1500V
Maximum Series Fuse Rating	20A
Nominal Operating Cell Temperature	45±2°C
Fire Rating	IEC Class C

CERTIFICATES

IEC 61215:2021 / IEC61730:2023

ISO9001:2015 / ISO14001:2015 / ISO45001:2018

Europe Standard / China Quality Certification Centre



10-year product warranty



25-year power output warranty

Module Type	HM300TC-MHG	HM305TC-MHG	HM310TC-MHG	HM315TC-MHG	HM320TC-MHG
Testing Condition	STC	STC	STC	STC	STC
Maximum Power(Pmax/W)	300	305	310	315	320
Open Circuit Voltage(Voc/V)	44.40	44.55	44.76	45.12	45.48
Short Circuit Current(Isc/A)	8.59	8.70	8.80	8.87	8.94
Maximum Power Voltage(Vmp/V)	36.90	37.02	37.20	37.50	37.80
Maximum Power Current(Imp/A)	8.13	8.24	8.33	8.40	8.47
Module Efficiency(%)	20.7	21.0	21.4	21.7	22.0
Temperature Coefficient of Isc			+0.04%/°C		
Temperature Coefficient of Voc			-0.23%/°C		
Temperature Coefficient of Pmax			-0.28%/°C		
* Under Standard Test Conditions (STC) of irradiance of 1000 W/m ² , spectrum AM 1.5 and cell temperature of 25°C.					

CAUTION: READ SAFETY AND INSTALLATION INSTRUCTIONS BEFORE USING THE PRODUCT.
©2025 Horay Solar Co., Ltd. All rights reserved.
Specifications included in this datasheet are subject to change without notice.

370W / 375W / 380W / 385W / 390W

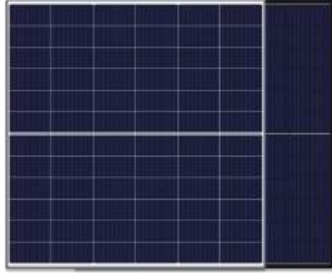

Dimension	1350×1303×30mm
Cell Orientation	72 (6×12)
Weight	17.5kg
Junction Box	IP68
Output Cable	4mm ² , length can be customized
Connector	MC4 compatible
Glass	3.2mm AR coated tempered glass
Frame	Anodized aluminum alloy frame
Operational Temperature	-40°C~+85°C
Power Output Tolerance	0~3%
Maximum System Voltage	1500V
Maximum Series Fuse Rating	20A
Nominal Operating Cell Temperature	45±2°C
Fire Rating	IEC Class C

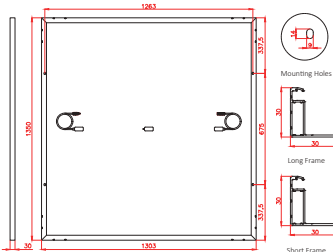

CERTIFICATES

IEC 61215:2021 / IEC61730:2023

ISO9001:2015 / ISO14001:2015 / ISO45001:2018

Europe Standard / China Quality Certification Centre

10 10-year product warranty

25 25-year power output warranty

Module Type	HM370TC-MHG	HM375TC-MHG	HM380TC-MHG	HM385TC-MHG	HM390TC-MHG
Testing Condition	STC	STC	STC	STC	STC
Maximum Power(Pmax/W)	370	375	380	385	390
Open Circuit Voltage(Voc/V)	26.64	26.86	27.03	27.16	27.29
Short Circuit Current(Isc/A)	17.65	17.74	17.86	18.01	18.16
Maximum Power Voltage(Vmp/V)	22.14	22.32	22.46	22.57	22.68
Maximum Power Current(Imp/A)	16.74	16.80	16.92	17.06	17.20
Module Efficiency(%)	21.0	21.3	21.6	21.9	22.2
Temperature Coefficient of Isc			+0.04%/°C		
Temperature Coefficient of Voc			-0.23%/°C		
Temperature Coefficient of Pmax			-0.28%/°C		

* Under Standard Test Conditions (STC) of irradiance of 1000 W/m², spectrum AM 1.5 and cell temperature of 25°C.

HORAY



Installation Manual for

HORAY PV Module Collection

Applicable Module Type

No.	Module Type	Size
1	HSxxxTC-MHG-D (xxx=670-730, in steps of 5, 132 cells)	2384x1303x35/33mm
2	HSxxxTC-MHG-D (xxx=610-660, in steps of 5, 120 cells)	2174x1303x35/33mm
3	HSxxxTC-MHG-D (xxx=560-605, in steps of 5, 110 cells)	2384x1096x35/33mm
4	HSxxxTC-MHG-D (xxx=550-595, in steps of 5, 108 cells)	1965x1303x35/33mm
5	HSxxxTC-MHG-D (xxx=510-550, in steps of 5, 100 cells)	2174x1096x35/33mm
6	HSxxxTC-MHC-D (xxx=585-640, in steps of 5, 132 cells)	2382x1134x30/35mm
7	HSxxxTC-MHC-D (xxx=535-580, in steps of 5, 120 cells)	2178x1134x30/35mm
8	HSxxxTC-MHC-D (xxx=475-520, in steps of 5, 108 cells)	1960x1134x30/35mm
9	HSxxxTC-MHC-D (xxx=425-465, in steps of 5, 96 cells)	1762x1134x30/35mm
10	HSxxxTC-MHO-D (xxx=560-605, in steps of 5, 144 cells)	2279x1134x35/30mm
11	HSxxxTC-MHO-D (xxx=515-550, in steps of 5, 132 cells)	2094x1134x35/30mm
12	HSxxxTC-MHO-D (xxx=470-500, in steps of 5, 120 cells)	1909x1134x35/30mm
13	HSxxxTC-MHO-D (xxx=420-450, in steps of 5, 108 cells)	1722x1134x35/30mm
14	HSxxx-MHG-D (xxx=640-660, in steps of 5, 132 cells)	2384x1303x35/30mm
15	HSxxx-MHG-D (xxx=585-600, in steps of 5, 120 cells)	2174x1303x35/30mm
16	HSxxx-MHG-D (xxx=535-550, in steps of 5, 110 cells)	2384x1096x35/30mm
17	HSxxx-MHG-D (xxx=485-500, in steps of 5, 100 cells)	2174x1096x35/30mm
18	HSxxx-MHO-D (xxx=535-560, in steps of 5, 144 cells)	2279x1134x35/30mm
19	HSxxx-MHO-D (xxx=495-515, in steps of 5, 132 cells)	2094x1134x35/30mm
20	HSxxx-MHO-D (xxx=450-470, in steps of 5, 120 cells)	1909x1134x35/30mm
21	HSxxx-MHO-D (xxx=405-420, in steps of 5, 108 cells)	1722x1134x35/30mm
22	HSxxx-MHL-D (xxx=445-465, in steps of 5, 144 cells)	2094x1038x35/30mm
23	HSxxx-MHL-D (xxx=410-425, in steps of 5, 132 cells)	1924x1038x35/30mm
24	HSxxx-MHL-D (xxx=370-385, in steps of 5, 120 cells)	1755x1038x35/30mm

1. Introduction

Thanks for choosing HORAY SOLAR photovoltaic (PV) modules.

Electrical and mechanical installation information will be introduced in this installation manual, so please read and understand the information before installing HORAY modules. In addition, this manual also contains important safety information that you should be familiar with. All contents in this manual are intellectual properties of HORAY which originates from long term of technical exploration and experience accumulation of HORAY.

This installation manual does not entail any explicit or implicit quality warranty and does not stipulate on compensation schemes for losses, module damages or other costs caused by or related to module installation, operation, utilization and maintenance process. When there is a dispute between the parties about the root -cause of module damage, the judgment is based on the quality standards as per contract.

HORAY will not take any responsibility if patent rights or the third party rights are infringed by use of modules. HORAY reserves the rights for modifying product manual or installation manual without advanced notice. It is recommended to visit our website regularly at www.horaysolar.com for the latest version of this installation manual.

If customers fail to install modules as per requirements set forth in this manual, the limited warranty provided for customers will be invalid. In addition, suggestions in this manual are to improve safety of module installation, which are tested and proved through years of experience, Please provide this manual to PV system users for reference and inform the advises on operation, maintenance requirements etc.

1.1 Rules and regulations

The mechanical and electrical installation of modules must comply with all local applicable regulations and codes, including electrical norms, including construction codes and electrical connection requirements, as well as mounting and other equipment instructions. Regulations may differ based on site-specific conditions, such as building roof installation, vehicle applications, etc. Additionally, requirements may vary depending on the installed system voltage (DC or AC). For specific terms, please contact your local authorities.

1.2 Disclaimer

HORAY reserves the right to change this user manual without prior notice. This user manual is not a warranty document and does not carry any warranty significance. If the components are not operated in accordance with the requirements listed in this manual during the operation process (including but not limited to product disassembly/packaging, loading/unloading, transportation, storage, installation, use, operation, or maintenance), it will result in the

invalidation of the product's limited warranty. HORAY is not responsible for any losses caused by improper operations or mistakes by the customer that do not follow the instructions in this user manual, including but not limited to any product damage, personal injury, or other property loss resulting from failure to follow the instructions in this manual during component operation.



Mandatory

Otherwise the product may be damaged or the user's personal safety may be endangered.



Prohibited

Otherwise the product may be damaged or the user's personal safety may be endangered.

2. General Information

Two labels on the module contain the information below:

1. Nameplate: product type, rated power, rated current, rated voltage, open circuit voltage, short circuit current under testing conditions, certification indicator, maximum system voltage, etc.
2. Serial Number label: A unique serial number which is laminated inside the module permanently which can be found in the front of the module. There is another same serial number beside the module nameplate.

2.1 Regular Safety

Handle modules during deliveries and transport with care to avoid large shocks that could damage the assembly or/and cause cracks in the cell.

Do not apply excessive force or objects on the module surface, do not impact, and do not twist the module frame to prevent cell damages and/or cell cracks.

Do not use the modules to replace or partly replace roofs and walls of buildings. Follow your local regulations for building integration of photovoltaic.

Avoid touching or modifying any part of the modules unless explicitly authorized by HORAY. Refrain from removing, attempting to repair, or disassembling any component installed by HORAY.

Junction boxes and female-male connectors interconnections of the modules covered by this manual meet IP68 (IEC60529) requirements, However, they must be protected from prolonged direct sunlight and water immersions to ensure long-term reliability.

Do not drill holes in the frame without authorization from HORAY, as it may cause corrosion or other negative effects.

Do not lift modules using the attached cables or the junction box.

Prohibit modules, junction boxes and connectors from coming into contact with unapproved chemicals: e.g., petrol, oil, acetone, alcohol, film strippers, potting compounds, TBP, cleaning agents, herbicides, rust inhibitors, descaling agents, etc. For more information, please contact HORAY technical support department.

Do not use junction boxes or connectors that are contaminated (with dust, corrosion, etc.), or broken modules.

Do not stand or step on the module as there is a risk of damage to the modules and injury to the user.

Pay attention to preventing sand, stones or other hard debris kicked up by operation and maintenance vehicles or lawn mowers during operation from striking the surface of the modules, causing glass or module damage.

Use appropriate protective equipment when installing modules to avoid direct contact, reduce the risk of electric shock, and protect hands from sharp edges. This includes standard and insulated safety tools and equipment (safety helmet, insulated gloves and rubber shoes, harness or belts, ladder, etc.).

When installing or maintaining the PV system, please do not wear metal rings, watches or other metal products, to avoid electric shock dangers or module damage.

Do not use wet tools, and refrain from working in rain, snow or windy conditions.

Modules should be stored at the project site with additional rain protection to avoid direct open-air placement before they are installed.

In order to avoid external matter such as sand or water vapour from entering and causing connection safety problems, once the modules are taken out of the box and installed, the connectors between the modules need to be connected in time, and the connectors need to be kept dry and clean during the installation process. In areas with heavy dust, high salinity, or severe pollution, dust plugs must be installed on the connectors to prevent contamination before the connectors are mated. Prior to purchasing the modules, it is necessary to communicate with HORAY about the project site conditions to ensure the provision of dust plugs. However, please note that the exposure time of dust plugs to the environment should not exceed one month.

2.2 Electrical performance safety

Modules generate DC electrical energy when exposed to sunlight or other light sources. Improper contact with live parts, such as terminals, may result in burns, sparks, and lethal shock.

Damage to, or opening of the front or rear glass of the module allow moisture ingress that compromise the internal circuit of the panel, can create serious electrical hazards, including the risk of fire. These modules cannot be repaired and must be removed and replaced immediately.

Electrical specifications shown in data-sheets are measured under Standard Test Conditions (STC, thus: Irradiance 1000W/m^2 , module cell temperature 25°C , air mass = 1,5. The current and voltage generated by modules in different environments are different from measured at

STC. Therefore, when determining the specifications of the rated voltage, cable capacity, fuse capacity, controller capacity, and other output power related specifications, take the values of 1.25 times the short-circuit current and open-circuit voltage marked on the module. This multiplier serves as a reference and is commonly used, however, it is important to consult with your inverter/controller supplier for system configuration design, as local regulations may vary, impacting these considerations.

Snow, water, or other reflective medium in surrounding environments that intensify light reflection will increase output current and power. And module voltage and power will increase under low temperature condition.

Artificially concentrated sunlight shall not be directed on the module. Do not expose the back of the single glass module directly to sunlight.

To prevent arcs and electrical shocks, do not disconnect modules under load without authorization; if disconnecting the connector is needed, turn off DC and AC inverters or cut off the main switch of the converter first.

PV module operation can only be stopped when they are kept from sunlight or covered by hard board (opaque material) or UV-proof materials.

When connecting a battery storage system, follow the battery manufacturer's instructions for correct installation operation, and maintenance to ensure system operation and user safety.

Due to the risk of electrical shock, do not perform any work if the terminals of the module are wet.

Do not operate on wet modules, if this is needed, only by wearing PPE.

Please follow the cleaning requirements in this manual when cleaning modules, refer to section 6.2.

Only the modules of the same size and the specifications within same range can be connected in series.

The number of modules that can be connected at a PV installation shall be determined by a qualified institution or person in accordance with the design specifications of the photovoltaic system and the local electrical design specifications.

Connect the male and female connectors correctly, before connecting, always ensure that the contacts are corrosion free, clean, and dry; Check the wiring condition, all wires shall not be detached from the modules, and secure the wires with cable ties so that the wires do not scratch or squeeze the rear side of the module.

Do not touch the module, junction box or the connectors with bare hands during installation or under sunlight, regardless if the module is connected to or disconnected from the system. The glass surface and the frame may be hot, posing a risk of burns and electric shock.

Do not insert any metal object into the connector.

Keep connectors dry and clean, ensuring they are in good operating condition.

2.3 Operation safety

Read and follow the manual "Handling, Storage and Unpacking Instructions" to ensure proper management of the pallets. Custom unpacking methods are prohibited.

Before unpacking, please check the product type, power bins, serial number, and relevant suggestions on the paper of the packaging box.

It is recommended to use art knife or cutter to remove the packing belt and wrapping film. Violent removal is prohibited to avoid scratching the modules in the box.

Ensure a proper environment before unpacking as well as enough man force (2 people minimum) to prevent the module from slipping and hitting other modules, causing scratches, cracks, or deformation on the modules.

Once the modules are removed from the pallet, they shall be promptly installed and connected to the inverter. If they are not installed immediately, protective measures (such as adding rubber joint cover, etc) must be taken on the connectors' head to prevent water vapour, sand, dust, insects, or other contaminants from getting inside the connector and causing poor contact or corrosion of the connector.

When inspecting PV modules with AR coating technology, it will be normal to observe modules with a slight color difference at different angles.

Thermal expansion and contraction effects occur on the modules. During installation, the distance between two adjacent modules must be $\geq 10\text{mm}$. If there are special requirements, please confirm with HORAY before installation.

During the installation, as for module removal, maintenance, and any other related processes, it is recommended that the force applied between the cable and the connector, and the cable and the junction box, is not more than 60N.

Meaning of crossed -out wheeled dust bin:

(1) Do not dispose of electrical appliances as unsorted municipal waste, use separate collection facilities.

Contact your local government for information regarding the collection systems available.

(2) If electrical appliances are disposed of in landfills or dumps, hazardous substances can leak into the groundwater and get into the food chain, damaging your health and well-being.

(3) When replacing old appliances with new ones, the retailer is legally obligated to take back your old appliance for disposals at least free of charge.



2.4 Fire safety

Please use appropriate module components to comply with local laws and regulations, as well as the building fire safety requirements before installation, such as fuses, circuit breakers and grounding connectors, etc.

HORAY modules fire rating is set according to IEC61730-2:2023 standard, and it can be found in the corresponding certificates. The fire Class Rating of a module for roof mounted system shall meet local code requirements in order to achieve the specified System fire Class Rating for a non-BIPV module. All PV systems have limitations of inclination required to maintain a specific System Fire Class Rating.

For roof-top installations, it is responsibility of the designers or installers to ensure that the roof is suitable not only in terms of the structural load-bearing capacity, but also the fire resistance for the installation of the PV modules in accordance to local regulation.

Make sure that the rear side of the module and the mounting surface are fully ventilated. When To facilitate ventilation and heat dissipation of the module, the minimum distance between the lower edge of the module frame and the highest point of the mounting surface must be $\geq 10\text{cm}$. For special installation methods, such as on corrugated metal sheets, the distance between the lower edge of the module frame and the roof shall be determined by the installer according to local regulations. Adequate ventilation must be ensured under local climatic conditions to keep the module within its operating temperature range. For minimum clearance requirements for other special cases, please contact HORAY technical support department.

Different roof structures and installation modes will affect fireproof performance of buildings. Improper installation may lead to the risk of fire.

Do not install the modules anywhere close to open flames or flammable materials (hay, straw, wood, solvents, oils, etc.), or exposed to flammable and explosive gases.

3. Unpacking mode

First place the packing on the level, dry and flattened ground, then successively remove the wrapping film, packing strap, upper cover, and carton. If you need to stack the Modules, please place the tray on the level ground and the Modules must keep stacked on the tray; Number of Modules ≤ 10 pcs, stacking time ≤ 4 days. The space between two Modules must be stuffed with isolating material, and the height of the isolating material must be 15mm higher than the top of the Module (wiring box). Without the isolating material, horizontal stacking is not recommended.

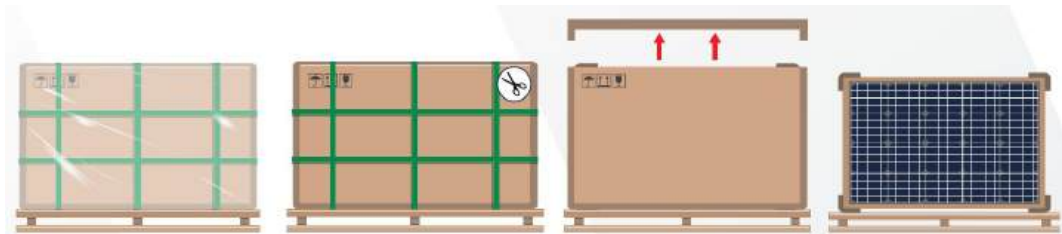

3.1 Enclosed unpacking

Prior to unpacking, please verify and confirm the intactness of the outer packing, and you are advised to remove the packing strap and wrapping film through a utility knife. Do not remove the packing materials with force, so as to avoid damage to the Modules inside.

After unpacking, please verify whether the number of Modules in the packing case and the bar-code information on the frame are the same with the shipping mark information.

Please secure the Modules in a reliably supported or fixed environment, and open the packing of the Modules according to the recommended unpacking procedure.

Based on different product models, the packing mode may be slightly varied. The precautions of unpacking are as follows.





Upon unpacking, the unpacking operation must be performed by 2 or more persons simultaneously. Operators shall wear protective insulating gloves when handling the Modules to avoid injury and prevent leaving fingerprints on the glass surface.

If the Modules are not completely withdrawn after unpacking, then the remaining Modules shall be placed horizontally for further repacking, so as to prevent tilting (upon repacking, the glass face of the lower level of Modules shall be upwards, the glass face of the top level of Modules shall be upwards, and the others downwards). The maximum number of Modules if stacked shall not exceed 16pcs.

If the Modules after unpacking are not subject to immediate installation (due to adverse weather conditions such as strong wind below scale 6, and provided that the number of Modules is less than 12pcs), then safety ropes shall be used to fix the vertical Modules and the leaning posts with protective measures. (As shown in the figure)



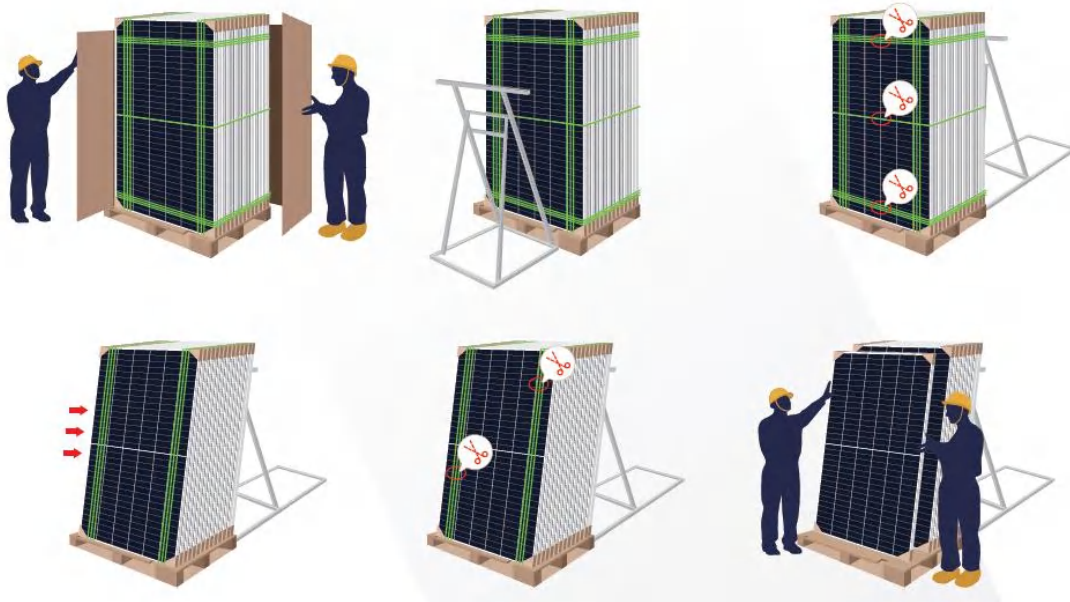

In windy weather conditions, please do not handle the Modules, and properly secure and fix any unpacked Modules.

Do not move the leaning posts during the unpacking process, so as to prevent tilting of the Modules.

Do not carry out outdoor unpacking operations in harsh weather conditions such as rain and snow.

Prior to removing the inner packing straps, please carry out proper protection to prevent titing of the whole unit of Modules.

The operation ground shall be able to ensure that the packing case is steadily placed and tilting is avoided.

Do not lean the Module on the installation post. Do not use wooden strips or other items to directly contact and support the rear side of the Module.

Do not handle the Module by a single operator, so as to avoid scratches, deformation or cracks of the Module due to sliding and collision of the Module with other Modules. When lifting the Module, do not pull the wiring box or cables to withdraw the Module.

Please carry out the operation in strict accordance with the requirements of unpacking instructions. When removing the packing straps of horizontal packing, please provide protective measures to avoid scratching your face or eyes, and avoid standing on the tray during unpacking, but handle the Modules from the two sides of the tray.

4. Installation conditions

4.1 Installation Site and Working Environment

The modules cannot be used in space.

Do not manually focus sunlight with mirrors or magnifying glass onto modules.

HORAY modules shall be installed on proper buildings or other appropriate places (such as ground, garage, building outer wall, roof, PV tracking system) but shall not be installed on any vehicles.

Do not install modules at places that are possible to be flooded.

HORAY suggests that modules be installed in the working environment with the temperature of -40°C to 40°C of which is the monthly average highest and lowest temperature of the installation sites. The extreme working environment temperature for modules is -40°C to 85°C .

Make sure that installed modules do not suffer wind or snow pressure that exceeds the permissible maximum load limit.

Modules shall be installed in places free from shadows throughout the year. Make sure there are no light-blocking obstacles in the installation sites.

Carry out lightning protection for modules installed in places with frequent lightning and thunder.

Do not install modules in places with possible inflammable gases.

Modules cannot be used in environments with too much hails, snows, flue gas, air pollution and soot or in places with strong corrosive substances such as salt, salt mist, saline, active chemical steam, acid rain, or other substances corroding modules, affecting modules' safety or performance.

Please take protective measures to ensure reliable and safe installation of modules in severe environments such as heavy snow, cold and strong wind or islands close to water and salt mist or deserts.

HORAY modules passed the IEC 61701 salt spray corrosion test, but the corrosion may still occur where the modules frame is connected to the bracket or where the grounding is connected. HORAY modules can be installed ≥ 50 m away from the ocean side. The Sea-Shield modules are suitable for nearshore pile-mounted applications, typically within 10 km from the coastline and in waters less than 10 meters deep.

4.2 Selection of Tilt Angles

Tilt angle of PV modules refer to the included angle between module surface and horizontal ground. The module will obtain the maximum power output when directly facing the sunlight.

Modules are preferred to be south-facing in the north hemisphere and north-facing in the south hemisphere. Please refer to standard modules installation guideline or suggestions from experienced PV module installer, for the specific installation angle.

HORAY suggests that tilt angle of module installation be no less than 10°, so module surface dust can be washed away easily by rainfall and frequency of cleaning can be reduced. And it is easy for accumulated water to flow away physically and avoid water mark on the glass surface which may further affect module appearance and performance.

HORAY modules connected in string should be installed with the same orientation and tilt angle. Different module orientation and tilt angle may result in different levels of solar irradiation and also power generation. In order to achieve the maximum annual generating capacity, the optimal orientation and inclination of PV modules in the installed area should be selected to ensure that sunlight can still reach to modules even on the shortest day of the year.

If HORAY modules are used in off-grid System, the tilt angle should be calculated based on seasons and irradiation to maximize the output power. If the modules output power meets the acquired load under the period of the worst irradiation in the year, the modules should be able to meet the load of the whole year. If the HORAY modules are used in grid-connected system, the tilt angle should be calculated based on the principle to maximize the yearly output power.

5. Mechanical Installation

5.1 Regular Requirements

Make sure that installation method and mounting structure are solid enough to meet the expected load-bearing requirement, which is requisite assurance from PV system installer. Installation bracket system shall be tested and inspected by the third party testing institution with static mechanical analysis capacity in accordance with local national standards or international standards.

Mounting structure shall be made from durable, corrosion resistant, UV-proof materials.

Modules shall be fixed on the bracket solidly.

In regions with heavy snowfall in winter, adjust the height of the mounting system so that the lower edge of the modules not covered by snow. Also, in order to reduce the risk of hot spots caused by flying sand and rocks damaging the module and shading, the lowest point of the module should be at a certain height to avoid the module being blocked by weeds and shrubs growing on the ground.

If modules are installed on brackets parallel to the roof, the minimum gap between the module frame and the roof/wall shall be 10cm which is good for air circulation to achieve better performance of module, Make sure the building is suitable for installation before installing modules on roof. Moreover, seal properly to prevent leakage.

The module frames can encounter thermal expansion and cold contraction. So the minimum distance between two adjoining modules shall be no less than 10 mm (0.39 inch). The specific space interval can be calculated according to the actual installation tolerance and deformation of the mounting bracket.

Ensure that the back-sheet, the front and rear glass of the module will not directly touch the mounting bracket, building structure, and environmental foreign objects (such as stones), especially under the action of external force, which will cause damage to the packaging back-sheet and glass, and therefore the product warranty is invalid.

Maximum static load of the PV module is down force 5400 Pa and uplift force 2400 Pa, which can vary from different mounting methods of the modules (please refer to the following installation guidance), the described load in this manual is for the test load.

Note: on the basis of IEC 61215-2016 installation requirements, when computing the corresponding maximum design load, a safety factor of 1.5 need to be considered in compliance with the local laws or regulations. (Test load = design load *1.5 times safety factor)

The modules can be installed in either landscape or portrait orientation. When installing the modules, be cautious not to block the drain hole of the frame. (* Note: in order for the modules to prevent dust accumulation, the anti-soiling modules must be mounted in portrait orientation.)

5.2 Module Mechanical installation

Module and bracket system connection can be realized by mounting holes, clamps or embedded systems. Installation shall follow the demonstration and suggestions below. If installation mode is different, please consult HORAY customer service personnel and obtain approval. Otherwise, modules may be damaged and limited warranty will be invalid. (* Note, regarding to Anti-Soiling modules only, short edge design has applied on prevention of dust from accumulating on modules, therefore , do not install at the short edge.

For special solar farm application scenarios such as heavy wind loads, valleys and steep cliffs, the installation method needs to be reinforced, and it is recommended to use Oval Washer, Flange nuts, bolts and clamps used together, and other reinforcement installation methods. For specific enquiry, please consult HORAY's customer service.)

5.2.1 Bolts Mounting

The HORAY's module has mounting holes matching M8 bolts. See the following figure for installation details and corresponding hole positions.

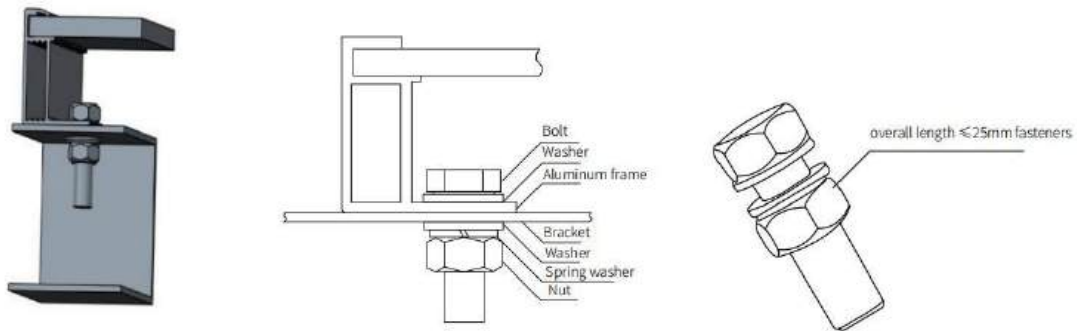

Recommended accessories are as below:

Accessories	Model	Material	Note
Bolt	M8	Q235B/SUS304	Accessories material selection should be based on application environment.
Washer	2pcs, thickness $\geq 1.5\text{mm}$ and outside diameters=16mm	Q235B/SUS304	
Spring Washer	8	Q235B/SUS304	
Nut	M8	Q235B/SUS304	

Suggestion : M8 bolt tightening torque range: 12-16 N·m; When using HORAY 30 mm height frame module, it is recommended to select overall length $\leq 25\text{mm}$ fasteners.

5.3.2 Clamp Mounting

The module can be mounted by a dedicated clamp, as shown in Figure.

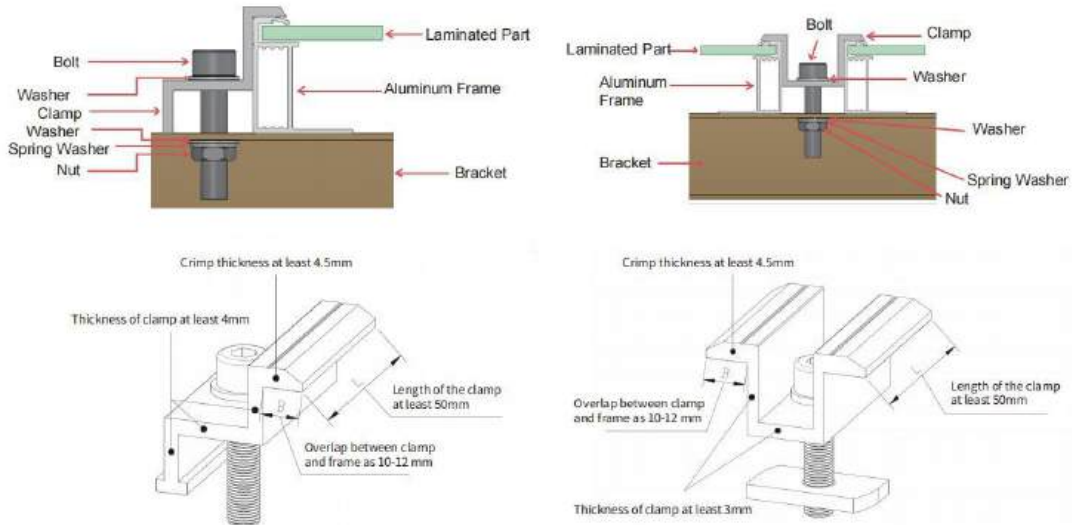

Under no circumstances should the clamp touch the glass or deform the frame. the interface of the clamp to the front of the frame must be smooth and flat to prevent frame or other components from being damaged.

Make sure that there are no shadows caused by clamps. The drain holes of module cannot be blocked by clamps. For framed PV module, it is recommended that the length of the clamp be at least 50mm, the clamp must maintain an overlap of 10-12 mm with the frame of the module (For clamp installation with an overlap of less than 10mm, HORAY technicians need to be consulted for assessment).

Regarding to the reference value of tightening torque, it is suggesting that for M8 bolt is 12 -16 N·m, M6 is 8 -12 N·m.

5.3 Installation and Mechanical Load of Bi-facial module

Bifacial modules can be mounted by bolts or clamps. The mounting method and maximum test load are shown as follow. (The unit of distance and length in the table below is millimeter (mm), and the unit of pressure is Pascal (Pa)).

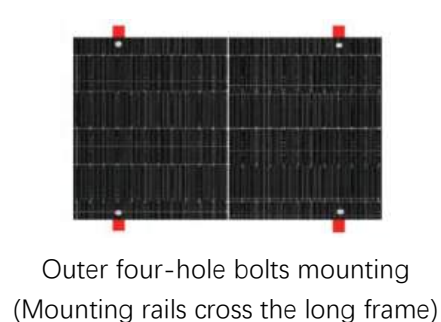
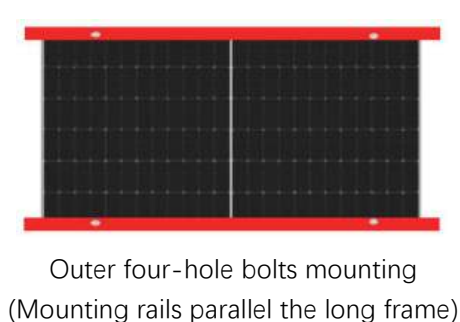

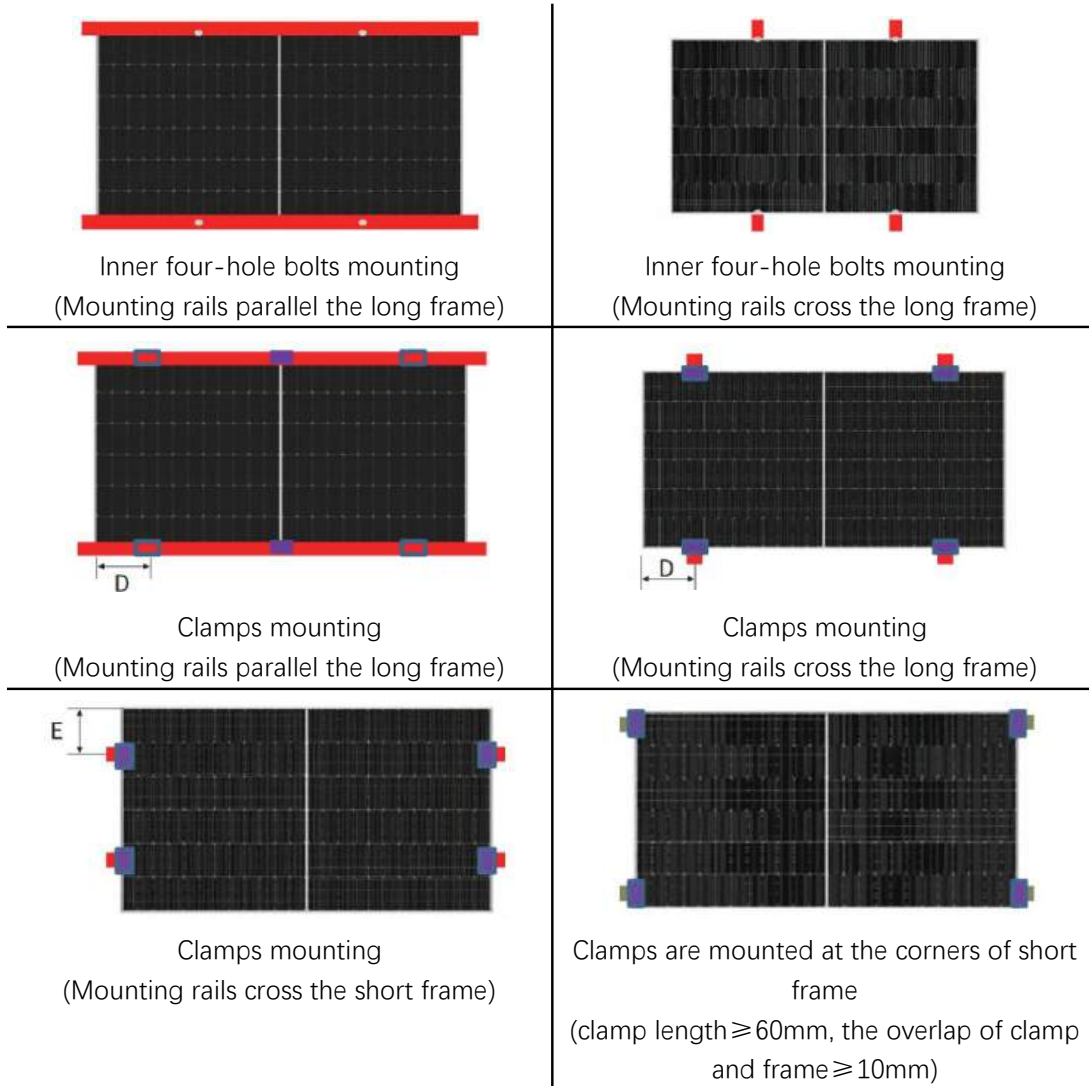

Mechanical loads information of 1722*1134 with framed bi-facial dual glass modules:

Module Type		Installation Method	Bolts Mounting		Clamps Mounting		
			Mounting rails cross the long frame		Mounting rails cross the long frame	Mounting rails cross the short frame	Clamps are mounted at the corners of short frame
			Outer four-hole	Inner four-hole	$250 \leq D \leq 350$	$235 \leq E \leq 335$	/
dual glass module	HSXXX-MHO-D (108 CELLS)	+2400, -2400	+5400, -2400	+5400, -2400	+2400, -2400	/	
	HSXXXTC-MHO-D (108 CELLS)	+2400, -2400	+5400, -2400	+5400, -2400	+2400, -2400	/	

Mechanical loads information of 1762*1134 with framed bi-facial dual glass modules:

Module Type		Installation Method	Bolts Mounting		Clamps Mounting		
			Mounting rails cross the long frame		Mounting rails cross the long frame	Mounting rails cross the short frame	Clamps are mounted at the corners of short frame
		Outer four-hole	Inner four-hole	$390 \leq D \leq 490$	$235 \leq E \leq 335$	/	
1762*1134 Framed bifacial dual glass module	HSXXXTC-MHA-D (108 CELLS)	+1600, -1600	+5400, -2400	+5400, -2400	+2400, -2400	/	
	HSXXXTC-MHC-D (96 CELLS)	+1600, -1600	+5400, -2400	+5400, -2400	+2400, -2400	/	

Mechanical loads information of 1909*1134 with framed bi-facial dual glass modules:

Module Type		Installation Method	Bolts Mounting		Clamps Mounting		
			Mounting rails cross the long frame		Mounting rails cross the long frame	Mounting rails cross the short frame	Clamps are mounted at the corners of short frame
		Outer four-hole	Inner four-hole	$390 \leq D \leq 490$	$235 \leq E \leq 335$	/	
1909*1134 Framed bifacial dual glass module	HSXXXTC-MHO-D (120 CELLS)	+1600, -1600	+5400, -2400	+5400, -2400	+2400, -2400	/	
	HSXXX-MHO-D (120 CELLS)	+1600, -1600	+5400, -2400	+5400, -2400	+2400, -2400	/	

Mechanical loads information of 2094*1134 with framed bi-facial dual glass modules:

Module Type		Installation Method	Bolts Mounting		Clamps Mounting		
			Mounting rails cross the long frame		Mounting rails cross the long frame	Mounting rails cross the short frame	Clamps are mounted at the corners of short frame
			Outer four-hole	Inner four-hole	$400 \leq D \leq 500$	$235 \leq E \leq 335$	/
2094*1134 Framed bifacial dual glass module	HSXXXTC-MHO-D (132 CELLS)	+1600, -1600	+5400, -2400	+5400, -2400	+2400, -2400	/	
	HSXXX-MHO-D (132 CELLS)	+1600, -1600	+5400, -2400	+5400, -2400	+2400, -2400	/	

Mechanical loads information of 2279*1134 with framed bi-facial dual glass modules:

Module Type		Installation Method	Bolts Mounting		Clamps Mounting		
			Mounting rails cross the long frame		Mounting rails cross the long frame	Mounting rails cross the short frame	Clamps are mounted at the corners of short frame
			Outer four-hole	Inner four-hole	$450 \leq D \leq 550$	$235 \leq E \leq 335$	/
2279*1134 Framed bifacial dual glass module	HSXXXTC-MHO-D (144 CELLS)	+2400, -2400	+5400, -2400	+5400, -2400	+2400, -2400	/	
	HSXXX-MHO-D (144 CELLS)	+2400, -2400	+5400, -2400	+5400, -2400	+2400, -2400	/	

Mechanical loads information of 2382*1134 with framed bi-facial dual glass modules:

Module Type		Installation Method	Bolts Mounting		Clamps Mounting		
			Mounting rails cross the long frame		Mounting rails cross the long frame	Mounting rails cross the short frame	Clamps are mounted at the corners of short frame
			Outer four-hole	Inner four-hole	$450 \leq D \leq 550$	$235 \leq E \leq 335$	/
2382*1134 Framed bifacial dual glass module	HSXXXTC-MHC-D (132 CELLS)	+5400, -2400	0	+5400, -2400	+2400, -2400	/	
	HSXXXTC-MHB-D (144 CELLS)	+5400, -2400	0	+5400, -2400	+2400, -2400	/	

Mechanical loads information of 2384*1134 with framed bi-facial dual glass modules:

Module Type		Installation Method	Bolts Mounting		Clamps Mounting		
			Mounting rails cross the long frame		Mounting rails cross the long frame	Mounting rails cross the short frame	Clamps are mounted at the corners of short frame
			Outer four-hole	Inner four-hole	$450 \leq D \leq 550$	$270 \leq E \leq 385$	/
bifacial dual	Framed HSXXXTC-MHG-D (132 CELLS)	+5400, -2400	0	+5400, -2400	+2400, -2400	/	

The above data is based on the static load requirements of IEC61215 standard (Tested by HORAY or third party certification institution).

6. Electrical installation

6.1 Electrical Performance

There are tolerances between the rated values of the electrical performance under STC and measured values. Including I_{sc} , V_{oc} and P_{max} under STC (1000 W/m² Irradiance, a cell temperature of 25°C and an AM 1.5).

When modules are in series connection, the string voltage is sum of every individual module in one string. When modules are in parallel connection, the current is sum of the individual module as shown in below figure 9. Modules with different electric performance models cannot be connected in the same string.

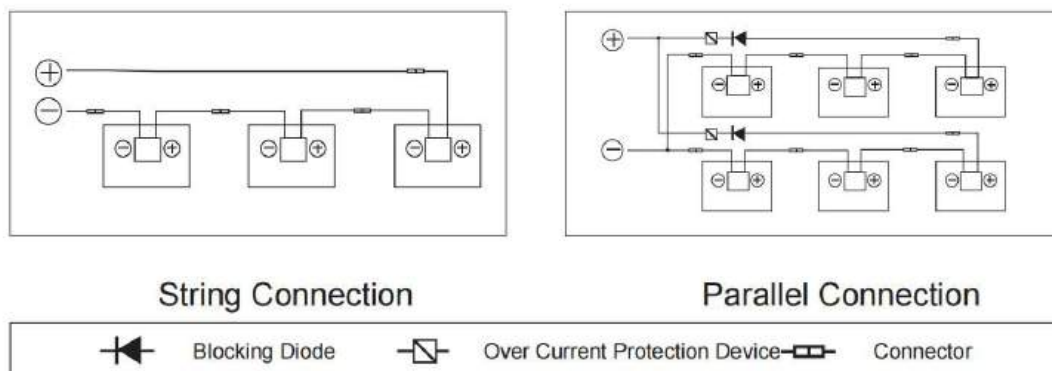

The maximum allowed quantity of modules in string connection shall be calculated according to relative regulations. The open circuit voltage value under the expected lowest temperature shall not exceed the maximum system voltage value allowed by modules and other values required by Dc electric parts. (HORAY modules maximum system voltage is DC1000V/ DC 1500V, actually system voltage is designed based on the selected module and inverter model.)

The correction value of V_{OC} can be calculated by the following formula: $C_{VOC} = 1 - \beta_{VOC} \times (25 - T)$.
 T: The expected lowest temperature of the installation site. β : V_{OC} temperature coefficient (% /°C) (Refer to module data sheet for further detail). If there has reverse current exceeding the maximum fuse current flowing through the module, use over current protection device with the same specifications to protect the module. If quantity of parallel connection is more than 2, there must be an over current protection device on each string of module.

6.2 Cables and Wiring

PV Module's junction boxes with the IP67 protective level, can provide the safety protection for cable and wiring connection, also for contact protection of non-insulating electric parts. Each module has two individual wires connecting the junction box, one is negative pole and the other is positive pole. Two modules can be in series connection by inserting the positive pole at

one end of wire of one module into the negative pole of the adjoining module.

According to local fire protection, building and electrical regulation, apply proper cable and connector, ensure the electrical and mechanical property of the cables (the cables should be put in a catheter with anti-UV aging properties, and if exposed to air, the cable itself should have anti-UV aging capability). For rooftop projects, it is important to utilize support and fixation measures to prevent module cables from hanging on the ground or the rooftop, ensuring the safety and durability of the cables.

The installer can only use single-wire cable, $\geq 4\text{mm}^2$ (12 AWG), 90 °C , with proper insulation capability to withstand the maximum open circuit voltage (such as EN50618 approval). Need to select appropriate wire specifications to reduce voltage drop.

HORAY requires that all wiring and electrical connections comply with the appropriate National Electrical Codes.

When cables are fixed on the bracket, avoid mechanical damaging cables or modules. Do not press cables by force. Adopt UV resistant cable ties and clamps to fix cables on the bracket. Though cables are UV resistant and water proof, it is still necessary to prevent cables from direct sun light and water immersion.

The minimum allowed bending radius of cables should be 43mm. (1.69 inch)

6.3 Connector

Please keep connectors clean and dry. Make sure connector caps are fastened before connection.

Avoid foreign objects such as moisture, dust, and organisms from entering the connector, which may cause the connector to fail to work properly or be damaged.

If the connector is wet, it is forbidden to connect.

If the connector is contaminated, it is forbidden to connect it.

If the connector is not connected positive with negative, the connector is not waterproof.

The components need to be connected as soon as possible after installation, and the connectors should meet the requirements of IP68 (IEC60529) after the connection. If the connector cannot be connected on time or the installation place is rainy and foggy, it is recommended to add a connector protection device.

Avoid connectors from direct sun light and water immersion. Avoid connectors falling onto ground or roof. incorrect connection may lead to electric arc and electric shock. Please make

sure that all electric connection is reliable, Make sure all connectors are fully locked.

Do not connect different connectors (brand and model) together.

6.4 Bypass diode

HORAY module junction box contains bypass diode which is in parallel connection with the cell string. If hot spot occurred, the diode will come into operation to stop the main current from flowing through the hot spot cells in order to prevent module over-heated and performance loss. Note, a bypass diode is not the over current protection device.

If the diode is definite or suspected to be defective, the installer or system maintenance supplier shall contact HORAY. Please do not try to open the module junction box on your own.

7. Grounding

In design of modules, the anodized corrosion resistant aluminum alloy frame is applied for rigidity support. For safety consideration and to protect modules from lightning and electrostatic damage, the module frame must be grounded. The grounding device must be in full contact with inner side of the aluminum alloy and penetrate surface oxide film of the frame.

Do not drill additional grounding holes on module frame.

The grounding conductor or wire may be copper, copper alloy, or any other material acceptable for application as an electrical conductor per respective National Electrical Codes. The grounding conductor must then make a connection to ground with a suitable ground electrode.

There are grounding holes with the diameter of $\Phi 4.2$ mm at the edge location of module's back-side frame. The grounding hole on the frame is marked with typical grounding symbol according to IEC 61730-1 standard, which can (only be used for grounding, not for module installation).

Grounding between modules shall be confirmed by qualified electricians and grounding devices shall be manufactured by qualified electric manufacturer. The copper core wire used for the grounding clamp is recommended to be 12 AWG. And copper wires cannot be pressed during installation in case of damaging.

The following is one of the recommended grounding methods of HORAY modules:

Align grounding clamp to the frame mounting hole. Use grounding bolt to go through the grounding clamp and frame.

Put the tooth side of the washer on the other side and fasten the nuts.

Put grounding wires through the grounding clamp and grounding wire material and dimension shall meet requirements in local national and regional law and regulations

Fasten bolts of grounding wires and then installation is completed.

Mounting holes on modules that are not occupied can be used for installing grounding devices.

The third party grounding device can be used for grounding of HORAY modules but such grounding method shall be proved to be reliable. Grounding device shall be operated in line with stipulations of the manufacturer.

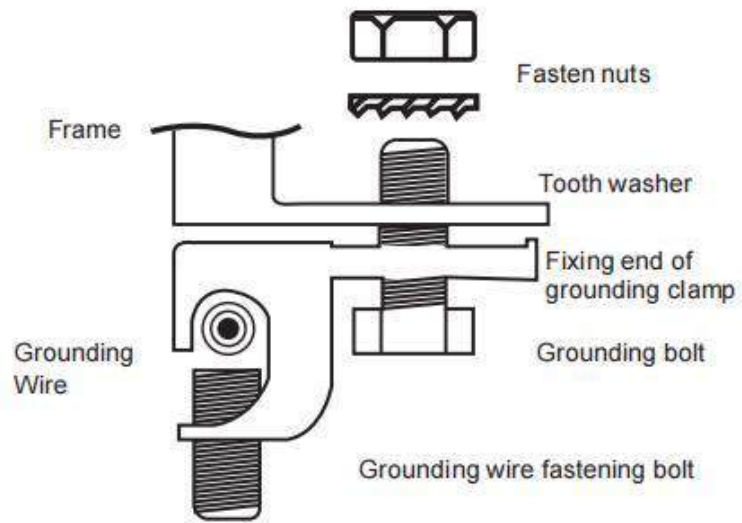

8. Operation and maintenance

It is the users' responsibility to carry out regular inspection and maintenance for modules, especially during the period of limited warranty. To inform the HORAY customer service personnel within two weeks when modules are found broken or other significant abnormality. Refer to the HORAY PV Module Operation and Maintenance Manual for details on module maintenance.

8.1 Cleaning

Accumulated contaminants on module surface glass will reduce the power output and lead to local hot spot, such as dust, industrial wasted water and birds' droppings. The severity of influence is determined by transparency of wastes. Small amounts of dust will affect the intensity and evenness of received solar irradiation but are not dangerous and power will not be reduced remarkably generally.

During operation of modules, there shall be no environmental factors to shade modules fully or partially. These environment factors including other modules, module mounting system, birds dwelling, dust, soil or plants. These will significantly reduce output power. HORAY suggests that the module surface should not be shadowed in any case.

Frequency of cleaning depends on dirt accumulation speed. In normal situations, rainwater will clean the module surface and reduce the cleaning frequency. it is suggested to use sponge dipped with clean water or soft cloth to wipe the glass surface. Do not use acid and alkaline detergents to clean modules. Do not use tool with rough surface to clean in any case.

In order to avoid potential risk of electrical shock or burn, HORAY suggests cleaning the modules during early morning or evening with low irradiance and low modules temperature especially for the hot regions.

In order to avoid potential risk of electrical shock, do not try to clean the modules with glass damage or expose wires.

8.2 Module Appearance Inspection

Check module cosmetic defects with naked eyes , especially:

Module glass cracks. Special attention: avoiding rolling up sand and gravel to break the glass during the inspection of the operation and maintenance vehicles; Avoiding defects or breakage of glass caused by splashing of hard objects such as sand and gravel when using a lawn mower for weeding operations.

Corrosion at welding parts of the cell main grid (caused by moisture into the module due to

damage of sealing materials during installation or transportation).

Check whether there are traces of burning mark on the module back sheet.

Check PV modules if any signs of aging including rodent damage, climate aging, connectors tightness, corrosion and grounding condition.

Check if any sharp objects in contact with PV modules' surface.

Check if any obstacles shading the PV modules.

Check if any loose or damage screws between the modules and mounting system. If so, adjust and fix in time.

8.3 Inspection of Connectors and Cables

It is suggested to carry out the following preventive inspection twice a year:

Check the tightness of the connectors and cables.

Check if any crack or gap of silicone nearby the junction box.

Solar Lake

370–385 Watt MONO-FACIAL MODULE

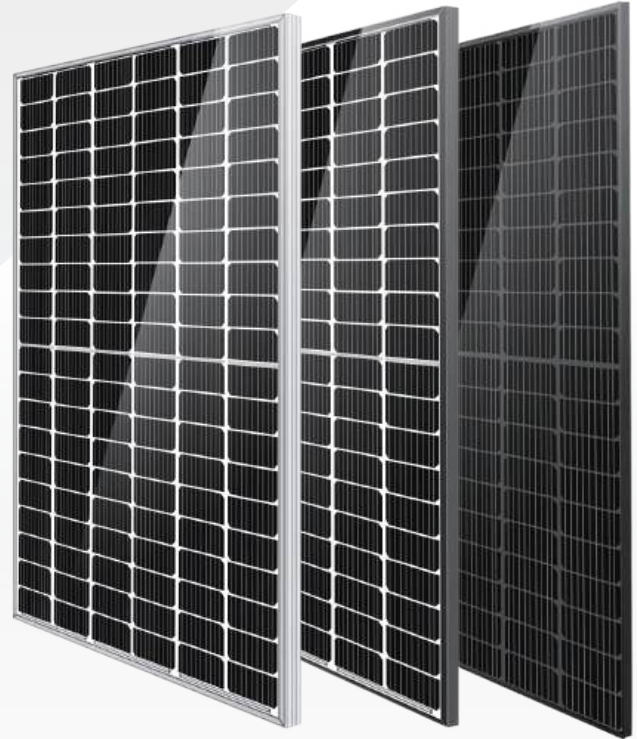

- IEC61215: 2021
- IEC61730: 2023
- TUV Rheinland Standard
- Lloyd'S Ariel Re
- Solar Performance Insurance
- ISO9001: 2015
- Quality Management System
- ISO14001:
- Environmental Management System
- CE: Europe Standard
- Inmetro Certificate
- Japan JP-AC
- China Quality Certification Centre
- Solar product certification

KEY FEATURES



MBB Cell
More uniform current collection capability, reducing the current heat loss of the internal cells.



Low Light Features
Higher performance under low light environment.



Higher Output Power
The output power of 120 half-cells Monocrystalline modules is up to 385W.



PID Protection
Ensure the attenuation probability caused by PID phenomenon is minimized.



Harsh Environmental Adaptability
Strict salt spray and ammonia corrosion test by the third party.



Load Capacity
Mechanical load tests including wind load 2400 Pa and snow load 5400 Pa.

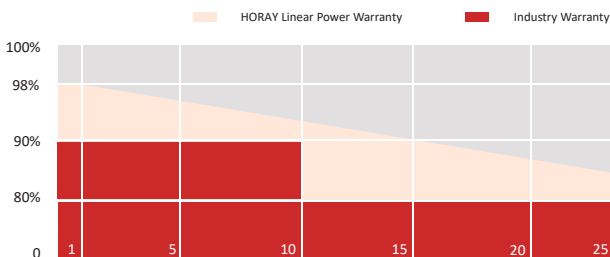

HEADQUARTER: HORAY SOLAR CO., LTD.

GLOBAL MARKETING AND SERVICE: HORAY SOLAR GMBH

✉ sales@horaysolar.com 🌐 www.horaysolar.com ☎ +86-510 83580688
📍 NO.30-5, East Yanxin Road, Huishan District, Wuxi 214177 Jiangsu P.R China

✉ info@horaysolar.com 🌐 www.horaysolar.com
📍 Robert-Bosch-StraBe 27-29,63225 Langen , Germany

MECHANICAL DIAGRAMS

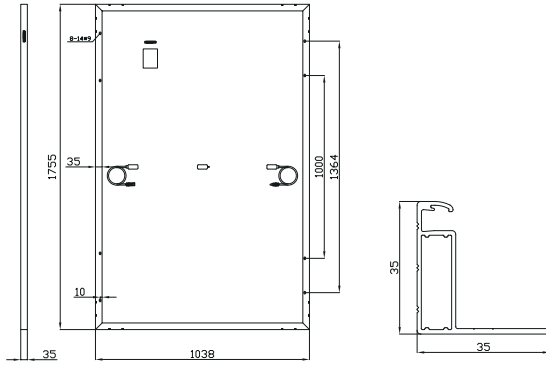

SPECIFICATIONS

Weight	20kg
Dimension	1755mm*1038mm*35mm
Cell Dimension	166*83mm
Cell Amount	60*2 pcs
Maximum System Voltage	1500V
Junction Box	IP68
Frame	Aluminum Alloy
Cable	4mm ² ,+300,-300mm/±1000mm Length can be customized
Connector	MC4 compatible
Application Level	Class A

ELECTRICAL PARAMETERS AT STC

Module Type	HS370-MHL	HS375-MHL	HS380-MHL	HS385-MHL
Power	370W	375W	380W	385W
Open Circuit Voltage	41.30V	41.50V	41.70V	41.90V
Short Circuit Current	11.37A	11.46A	11.55A	11.64A
Maximum Power Voltage	34.10V	34.30V	34.50V	34.70V
Maximum Power Current	10.86A	10.95A	11.04A	11.10A
Module Efficiency	20.31%	20.59%	20.86%	21.13%

* Under Standard Test Conditions (STC) of irradiance of 1000 W/ m², spectrum AM 1.5 and cell temperature of 25°C.

ELECTRICAL PARAMETERS AT NMOT

Power	280W	284W	288W	292W
Open Circuit Voltage	38.67V	38.90V	39.13V	39.46V
Short Circuit Current	9.10A	9.17A	9.24A	9.31A
Maximum Power Voltage	32.23V	32.42	32.61V	32.88V
Maximum Power Current	8.69A	8.76A	8.83A	8.88A
Module Efficiency	15.37%	15.59%	15.81%	16.03%

* Under Nominal Module Operating Temperature (NMOT), irradiance of 800 W/ m², spectrum AM 1.5, ambient temperature 20°C, wind speed 1 m/s.

TEMPERATURE CHARACTERISTICS

NMOT	45±2°C	Temp Coefficient of ISC	+0.05%/°C
Temp Coefficient of VOC	-0.28%/°C	Temp Coefficient of Pmax	-0.34%/°C

PACKING CONFIGURATION

Modules/Pallet	32 Pieces	Modules/40'Container	884 Pieces
Packaging Description	26 Pallets, Total=(32+32+4)x13=884 Pieces		

IV CHARACTERISTICS

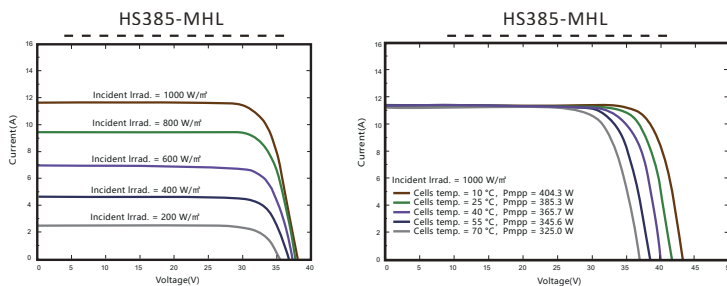

MAXIMUM RATING

Power selection	0~+5W
Measuring uncertainty of Pm	0~±3%
Operating Temperature	-40°C~+85°C
Wind Load/Snow Load	2400pa/5400pa
Fuse Current	20A

15 YEARS

Quality
Warranty

25 YEARS

Power
Warranty

CAUTION: READ SAFETY AND INSTALLATION INSTRUCTIONS BEFORE USING THE PRODUCT.

©2024 Horay Solar Co.,Ltd. All rights reserved. Specifications included in this datasheet are subject to change without notice.

Version number: MHO_EN_2024_A

Solar Lake

410–425 Watt MONO-FACIAL MODULE

- IEC61215: 2021
- IEC61730: 2023
- TUV Rheinland Standard
- Lloyd'S Ariel Re
- Solar Performance Insurance
- ISO9001: 2015
- Quality Management System
- ISO14001:
- Environmental Management System
- CE: Europe Standard
- Inmetro Certificate
- Japan JP-AC
- China Quality Certification Centre
- Solar product certification

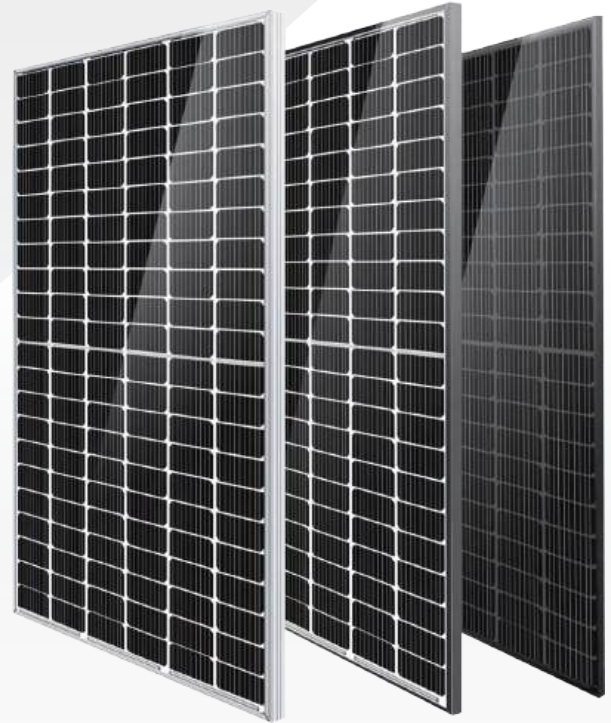

KEY FEATURES



MBB Cell
More uniform current collection capability, reducing the current heat loss of the internal cells.



Low Light Features
Higher performance under low light environment.



Higher Output Power
The output power of 132 half-cells Monocrystalline modules is up to 425W.



PID Protection
Ensure the attenuation probability caused by PID phenomenon is minimized.



Harsh Environmental Adaptability
Strict salt spray and ammonia corrosion test by the third party.



Load Capacity
Mechanical load tests including wind load 2400 Pa and snow load 5400 Pa.

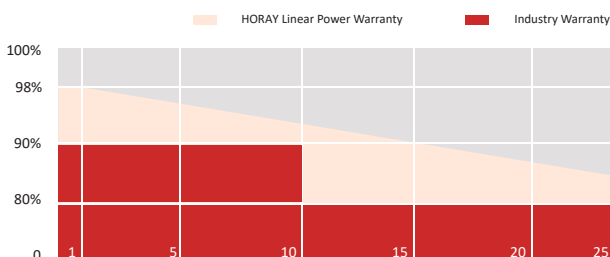

HEADQUARTER: HORAY SOLAR CO., LTD.

GLOBAL MARKETING AND SERVICE: HORAY SOLAR GMBH

✉ sales@horaysolar.com 🌐 www.horaysolar.com ☎ +86-510 83580688
📍 NO.30-5, East Yanxin Road, Huishan District, Wuxi 214177 Jiangsu P.R China

✉ info@horaysolar.com 🌐 www.horaysolar.com
📍 Robert-Bosch-StraBe 27-29,63225 Langen , Germany

MECHANICAL DIAGRAMS

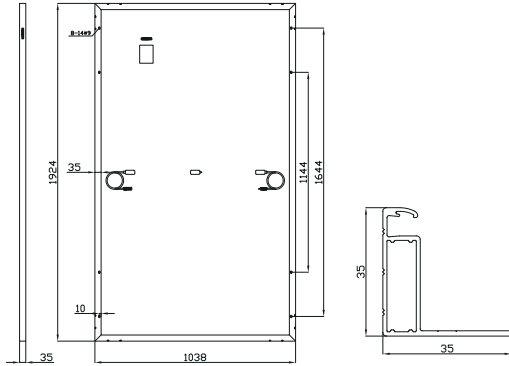

SPECIFICATIONS

Weight	21.3kg
Dimension	1924mm*1038mm*35mm
Cell Dimension	166*83mm
Cell Amount	66*2 pcs
Maximum System Voltage	1500V
Junction Box	IP68
Frame	Aluminum Alloy
Cable	4mm ² ,+300,-300mm/±1100mm Length can be customized
Connector	MC4 compatible
Application Level	Class A

ELECTRICAL PARAMETERS AT STC

Module Type	HS410-MHL	HS415-MHL	HS420-MHL	HS425-MHL
Power	410W	415W	420W	425W
Open Circuit Voltage	45.70V	45.90V	46.10V	46.30V
Short Circuit Current	11.43A	11.52A	11.61A	11.69A
Maximum Power Voltage	37.82V	38.02V	38.22V	38.42V
Maximum Power Current	10.84A	10.92A	10.99A	11.06A
Module Efficiency	20.53%	20.78%	21.03%	21.28%

* Under Standard Test Conditions (STC) of irradiance of 1000 W/ m², spectrum AM 1.5 and cell temperature of 25°C.

ELECTRICAL PARAMETERS AT NMOT

Power	310W	314W	318W	322W
Open Circuit Voltage	42.90V	43.13V	43.40V	43.67V
Short Circuit Current	9.14A	9.22A	9.29A	9.35A
Maximum Power Voltage	35.75V	35.94V	36.17V	36.39V
Maximum Power Current	8.67A	8.74A	8.79A	8.85A
Module Efficiency	15.52%	15.72%	15.92%	16.12%

* Under Nominal Module Operating Temperature (NMOT), irradiance of 800 W/ m², spectrum AM 1.5, ambient temperature 20°C, wind speed 1 m/s.

TEMPERATURE CHARACTERISTICS

NMOT	45±2°C	Temp Coefficient of ISC	+0.05%/°C
Temp Coefficient of VOC	-0.28%/°C	Temp Coefficient of Pmax	-0.34%/°C

PACKING CONFIGURATION

Modules/Pallet	32 Pieces	Modules/40' Container	816 Pieces
Packaging Description	24 Pallets, Total=(32+32+4)x12=816 Pieces		

IV CHARACTERISTICS

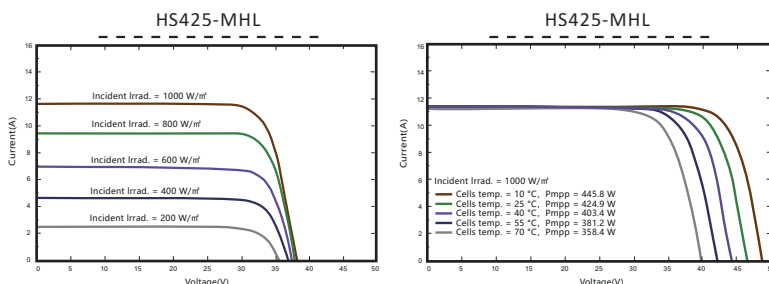

MAXIMUM RATING

Power selection	0~+5W
Measuring uncertainty of Pm	0~±3%
Operating Temperature	-40°C~+85°C
Wind Load/Snow Load	2400pa/5400pa
Fuse Current	20A

15 YEARS Quality Warranty

25 YEARS Power Warranty

CAUTION: READ SAFETY AND INSTALLATION INSTRUCTIONS BEFORE USING THE PRODUCT.

©2024 Horay Solar Co., Ltd. All rights reserved. Specifications included in this datasheet are subject to change without notice.
Version number: MHO_EN_2024_A

Solar Lake

445–465 Watt MONO-FACIAL MODULE

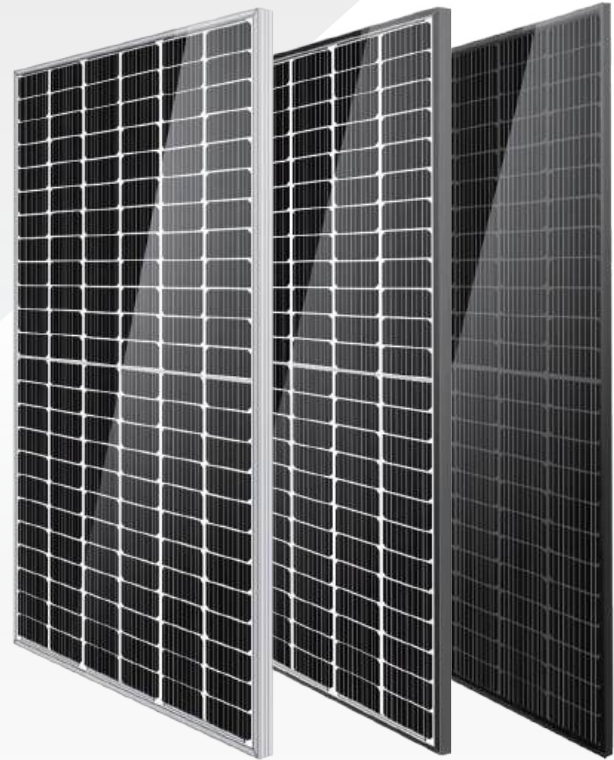

- IEC61215: 2021
- IEC61730: 2023
- TUV Rheinland Standard
- Lloyd'S Ariel Re
- Solar Performance Insurance
- ISO9001: 2015
- Quality Management System
- ISO14001:
- Environmental Management System
- CE: Europe Standard
- Inmetro Certificate
- Japan JP-AC
- China Quality Certification Centre
- Solar product certification

KEY FEATURES



MBB Cell
More uniform current collection capability, reducing the current heat loss of the internal cells.



Low Light Features
Higher performance under low light environment.



Higher Output Power
The output power of 144 half-cells Monocrystalline modules is up to 465W.



PID Protection
Ensure the attenuation probability caused by PID phenomenon is minimized.



Harsh Environmental Adaptability
Strict salt spray and ammonia corrosion test by the third party.



Load Capacity
Mechanical load tests including wind load 2400 Pa and snow load 5400 Pa.

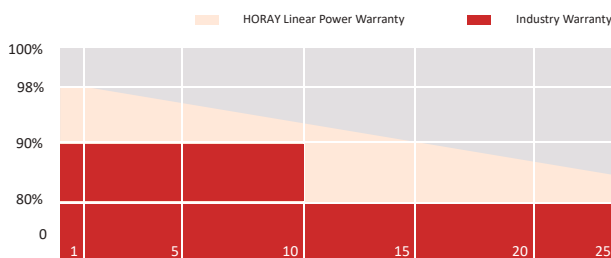

HEADQUARTER: HORAY SOLAR CO., LTD.

GLOBAL MARKETING AND SERVICE: HORAY SOLAR GMBH

✉ sales@horaysolar.com 🌐 www.horaysolar.com ☎ +86-510 83580688
📍 NO.30-5, East Yanxin Road, Huishan District, Wuxi 214177 Jiangsu P.R China

✉ info@horaysolar.com 🌐 www.horaysolar.com
📍 Robert-Bosch-StraBe 27-29,63225 Langen , Germany

MECHANICAL DIAGRAMS

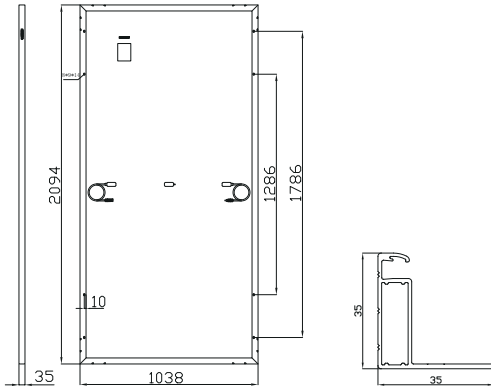

SPECIFICATIONS

Weight	24kg
Dimension	2094mm*1038mm*35mm
Cell Dimension	166*83mm
Cell Amount	72*2 pcs
Maximum System Voltage	1500V
Junction Box	IP68
Frame	Aluminum Alloy
Cable	4mm ² ,+300,-300mm/±1200mm Length can be customized
Connector	MC4 compatible
Application Level	Class A

ELECTRICAL PARAMETERS AT STC

Module Type	HS445-MHL	HS450-MHL	HS455-MHL	HS460-MHL	HS465-MHL
Power	445W	450W	455W	460W	465W
Open Circuit Voltage	49.80V	50.00V	50.20V	50.40V	50.60V
Short Circuit Current	11.40A	11.47A	11.54A	11.61A	11.68A
Maximum Power Voltage	41.20V	41.40V	41.60V	41.80V	42.00V
Maximum Power Current	10.81A	10.88A	10.94A	11.00A	11.08A
Module Efficiency	20.47%	20.70%	20.93%	21.16%	21.39%

* Under Standard Test Conditions (STC) of irradiance of 1000 W/ m², spectrum AM 1.5 and cell temperature of 25°C.

ELECTRICAL PARAMETERS AT NMOT

Power	336W	340W	344W	348W	352W
Open Circuit Voltage	46.62V	46.88V	47.17V	47.45V	47.65V
Short Circuit Current	9.12A	9.18A	9.23A	9.29A	9.34A
Maximum Power Voltage	38.85V	39.06V	39.31V	39.55V	39.71V
Maximum Power Current	8.65A	8.70A	8.75A	8.80A	8.86A
Module Efficiency	15.46%	15.64%	15.83%	16.01%	16.19%

* Under Nominal Module Operating Temperature (NMOT), irradiance of 800 W/ m², spectrum AM 1.5, ambient temperature 20°C, wind speed 1 m/s.

TEMPERATURE CHARACTERISTICS

NMOT	45±2°C	Temp Coefficient of ISC	+0.05%/°C
Temp Coefficient of VOC	-0.28%/°C	Temp Coefficient of Pmax	-0.34%/°C

PACKING CONFIGURATION

Modules/Pallet	32 Pieces	Modules/40'Container	748 Pieces
Packaging Description	22 Pallets, Total=(32+32+4)x11=748 Pieces		

IV CHARACTERISTICS

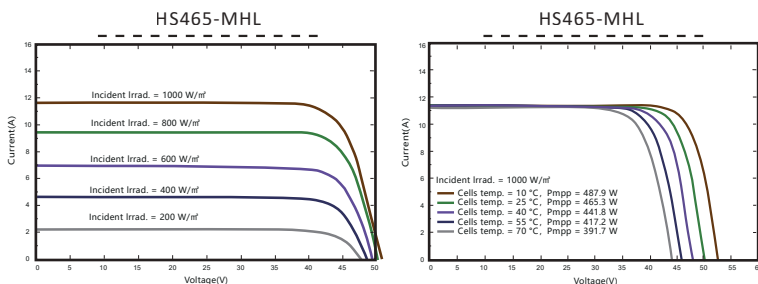

MAXIMUM RATING

Power selection	0~+5W
Measuring uncertainty of Pm	0~±3%
Operating Temperature	-40°C~+85°C
Wind Load/Snow Load	2400pa/5400pa
Fuse Current	20A

15 YEARS Quality Warranty

25 YEARS Power Warranty

CAUTION: READ SAFETY AND INSTALLATION INSTRUCTIONS BEFORE USING THE PRODUCT.

©2024 Horay Solar Co.,Ltd. All rights reserved. Specifications included in this datasheet are subject to change without notice.

Version number: MHO_EN_2024_A



ACHYRA[®]

Soluzioni Energetiche Sostenibili

Milano - Nola - HongKong - Guangzhou

CERTIFICAZIONI

HORAY SOLAR



思 | 平



Certificate NO: 37124Q0184R0M

Quality Management System Certification

This Proof

HORAY SOLAR CO., LTD

Unified social credit code: 91320206MA22MG1Q5R

Address: No.30-5 Yanxin East Road, Huishan District, Wuxi, Jiangsu, China(214100)

Quality Management System
is in conformity with

GB/T19001-2016/ISO9001:2015 Standard

The scope of certification covers

Manufacturing of solar cell modules

Date of Issue: Oct 10, 2024

Date of Renew: Oct 10, 2024

Date of Expiry: Oct 09, 2027

General Manager: 

Note: The organization will accept the supervision twice before Oct 09, 2025 and Oct 09, 2026. After that date, the certificate will be valid only when it is used together with the "Notice of maintaining the use of the certificate and certification mark". The validity of the certificate can be verified by scanning the QR code or by the websites of Siping Certification (Shanghai) Co., Ltd. and Certification and Accreditation Administration of the People's Republic of China, CNCA

Shanghai Siping Certification Website: www.spsrz.com

Meanwhile, you can search the CNCA website: www.cnca.gov.cn



中国认可
国际互认
管理体系
MANAGEMENT SYSTEM
CNAS C252-M



SIPING Certification Service(Shanghai) Co.,Ltd

ADD: Room 920, Jingding Building, No.399 Baiyin Road, Jiading District, Shanghai, China
postcode: 201801 Tel: 021-59184249



思 | 平



Certificate NO: Horay Rights

Environmental Management System Certification

This Proof

HORAY SOLAR CO., LTD

Unified social credit code: 91320206MA22MG1Q5R

Address: No.30-5 Yanxin East Road, Huishan District, Wuxi, Jiangsu, China(214100)

**Environmental Management System
is in conformity with
GB/T24001-2016/ISO14001:2015 Standard**

**The scope of certification covers
Relevant environmental management activities involved in the
manufacturing of solar cell modules**

Date of Issue: Dec 21, 2022

Date of Renew: Dec 21, 2022

Date of Expiry: Dec 20, 2025

General Manager:

Note: The organization will accept the supervision twice before Dec 20, 2023 and Dec 20, 2024. After that date, the certificate will be valid only when it is used together with the "Notice of maintaining the use of the certificate and certification mark". The validity of the certificate can be verified by scanning the QR code or by the websites of Siping Certification (Shanghai) Co., Ltd. and Certification and Accreditation Administration of the People's Republic of China, CNCA

Shanghai Siping Certification Website: www.spsrz.com

Meanwhile, you can search the CNCA website: www.cnca.gov.cn



中国认可
国际互认
管理体系
MANAGEMENT SYSTEM
CNAS C252-M



SIPING Certification Service(Shanghai) Co.,Ltd

ADD: Room 920, Jingding Building, No.399 Baiyin Road, Jiading District, Shanghai, China
postcode: 201801 Tel: 021-59184249



TEST REPORT

SGS-CSTC
Standards Technical Services
(Shanghai) Co., Ltd.
No.588 West Jindu Road,
Songjiang District,
Shanghai, China



Unless otherwise agreed in writing, this document is issued by the Company subject to its General Conditions of Service printed overleaf, available on request or accessible at <http://www.sgs.com/en/Terms-and-Conditions.aspx> and, for electronic format documents, subject to Terms and Conditions for Electronic Documents at <http://www.sgs.com/en/Terms-and-Conditions/Terms-e-Documents.aspx>. Attention is drawn to the limitation of liability, indemnification and jurisdiction issues defined therein. Any holder of this document is advised that information contained hereon reflects the Company's findings at the time of its intervention only and within the limits of Client's instructions, if any. The Company's sole responsibility is to its Client and this document does not exonerate parties to a transaction from exercising all their rights and obligations under the transaction documents. This document cannot be reproduced except in full, without prior written approval of the Company. Any unauthorized alteration, forgery or falsification of the content or appearance of this document is unlawful and offenders may be prosecuted to the fullest extent of the law. Unless otherwise stated the results shown in this test report refer only to the sample(s) tested and such sample(s) are retained for 30 days only.
Attention: To check the authenticity of testing / inspection report & certificate, please contact us at telephone: (86-755) 8307 1443, or email: CN.Doccheck@sgs.com
NO.588 West Jindu Road, Songjiang District, Shanghai, China 201612 t (86-21) 61915666 f (86-21) 61915678 www.sgs.com.cn
中国·上海·松江区金都西路588号 邮编: 201612 t (86-21) 61915666 f (86-21) 61915678 e sgs.china@sgs.com

Member of the SGS Group (SGS SA)

Report reference no.: Horay Rights -01
Date of issue.....: Dec. 05, 2022
Total number of pages: 11
Testing laboratory: SGS-CSTC Standards Technical Services (Shanghai) Co., Ltd.
Address: 588 West Jindu Road, Xinqiao, Songjiang, 201612 Shanghai, China

Applicant's name.....: HORAY SOLAR CO., LTD
Address: No. 30-5 Yanxin Road, Huishan District, Wuxi, Jiangsu, China
Test specification: Clause MQT 01, MQT 02, MQT 03, MQT 15 of IEC 61215-2:2016
Test item description: Photovoltaic (PV) module(s)
Trade mark: **HORAY**

Manufacturer: HORAY SOLAR CO., LTD
Address: No. 30-5 Yanxin Road, Huishan District, Wuxi, Jiangsu, China
Model/Type reference : HS500-MHO
Ratings: Refer to marking plate of sample



 Signature

Tested by: Janine Tian



 Signature

Approved by: Van Hua



Unless otherwise agreed in writing, this document is issued by the Company subject to its General Conditions of Service printed overleaf, available on request or accessible at <http://www.sgs.com/en/Terms-and-Conditions.aspx> and, for electronic format documents, subject to Terms and Conditions for Electronic Documents at <http://www.sgs.com/en/Terms-and-Conditions/Terms-e-Documents.aspx>. Attention is drawn to the limitation of liability, indemnification and jurisdiction issues defined therein. Any holder of this document is advised that information contained hereon reflects the Company's findings at the time of its intervention only and within the limits of Client's instructions, if any. The Company's sole responsibility is to its Client and this document does not exonerate parties to a transaction from exercising all their rights and obligations under the transaction documents. This document cannot be reproduced except in full, without prior written approval of the Company. Any unauthorized alteration, forgery or falsification of the content or appearance of this document is unlawful and offenders may be prosecuted to the fullest extent of the law. Unless otherwise stated the results shown in this test report refer only to the sample(s) tested and such sample(s) are retained for 30 days only.
 Attention: To check the authenticity of testing/inspection report & certificate, please contact us at telephone: (86-755) 8307 1443, or email: CN.Doccheck@sgs.com
 NO.588 West Jindu Road, Songjiang District, Shanghai, China 201612 t (86-21)61915666 f (86-21)61915678 www.sgs.com.cn
 中国·上海·松江区金都西路588号 邮编: 201612 t (86-21)61915666 f (86-21)61915678 e sgs.china@sgs.com

Member of the SGS Group (SGS SA)

List of tests performed

Test item	Requirement + Test	Result	Verdict
1	Visual inspection	See Table 1	P
2	Maximum power determination	See Table 2	P
3	Insulation test	See Table 3	P
4	Wet leakage current test	See Table 4	P

Pre-conditioning has been performed with an irradiance dose of 5.0 kWh/m².



Unless otherwise agreed in writing, this document is issued by the Company subject to its General Conditions of Service printed overleaf, available on request or accessible at <http://www.sgs.com/en/Terms-and-Conditions.aspx> and, for electronic format documents, subject to Terms and Conditions for Electronic Documents at <http://www.sgs.com/en/Terms-and-Conditions/Terms-e-Documents.aspx>. Attention is drawn to the limitation of liability, indemnification and jurisdiction issues defined therein. Any holder of this document is advised that information contained hereon reflects the Company's findings at the time of its intervention only and within the limits of Client's instructions, if any. The Company's sole responsibility is to its Client and this document does not exonerate parties to a transaction from exercising all their rights and obligations under the transaction documents. This document cannot be reproduced except in full, without prior written approval of the Company. Any unauthorized alteration, forgery or falsification of the content or appearance of this document is unlawful and offenders may be prosecuted to the fullest extent of the law. Unless otherwise stated the results shown in this test report refer only to the sample(s) tested and such sample(s) are retained for 30 days only.
 Attention: To check the authenticity of testing / inspection report & certificate, please contact us at telephone: (86-755) 8307 1443, or email: CN.Doccheck@sgs.com
 NO.588 West Jindu Road, Songjiang District, Shanghai, China 201612 t (86-21) 61915666 f (86-21) 61915678 www.sgs.com.cn
 中国·上海·松江区金都西路588号 邮编: 201612 t (86-21) 61915666 f (86-21) 61915678 e sgs.china@sgs.com

Member of the SGS Group (SGS SA)

Summary of testing

Submitted samples are tested according to Clause MQT 01, MQT 02, MQT 03, MQT 15 of IEC 61215-2:2016. The test results are present within this test report.

Tests performed (name of test and test clause):

IEC 61215-2-2016:
 Visual inspection (MQT 01)
 Performance at STC (MQT 02)
 Insulation test (MQT 03)
 Wet leakage current test (MQT 15)

Testing location:

Guoce Testing Technology (suzhou) Co., Ltd.
 Building 11, No. 18, Yaofeng East Road, Mudu Town,
 Wuzhong District, Suzhou, Jiangsu, 215151, China

Copy of marking plate / device under test:

Module Type: HS500-MHO

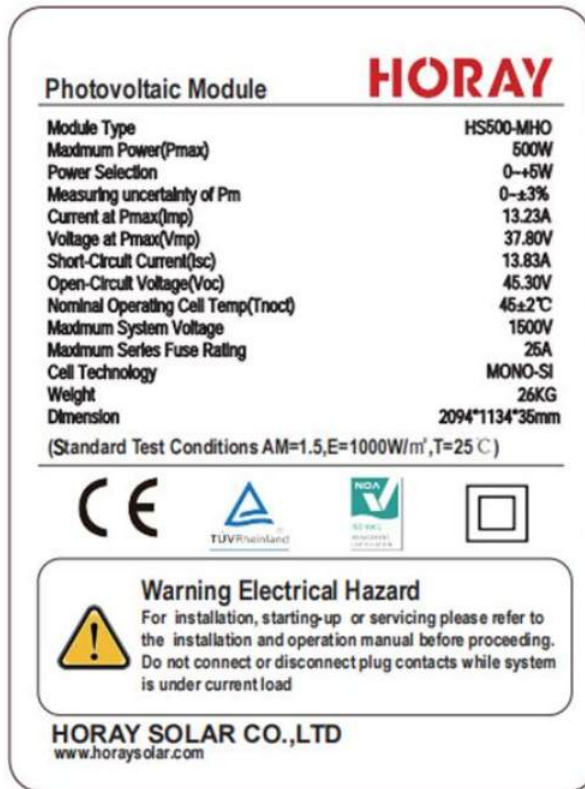

Marking plate of Sample



Unless otherwise agreed in writing, this document is issued by the Company subject to its General Conditions of Service printed overleaf, available on request or accessible at <http://www.sgs.com/en/Terms-and-Conditions.aspx> and, for electronic format documents, subject to Terms and Conditions for Electronic Documents at <http://www.sgs.com/en/Terms-and-Conditions/Terms-e-Documents.aspx>. Attention is drawn to the limitation of liability, indemnification and jurisdiction issues defined therein. Any holder of this document is advised that information contained hereon reflects the Company's findings at the time of its intervention only and within the limits of Client's instructions, if any. The Company's sole responsibility is to its Client and this document does not exonerate parties to a transaction from exercising all their rights and obligations under the transaction documents. This document cannot be reproduced except in full, without prior written approval of the Company. Any unauthorized alteration, forgery or falsification of the content or appearance of this document is unlawful and offenders may be prosecuted to the fullest extent of the law. Unless otherwise stated the results shown in this test report refer only to the sample(s) tested and such sample(s) are retained for 30 days only.

Attention: To check the authenticity of testing / inspection report & certificate, please contact us at telephone: (86-755) 8307 1443, or email: CN.Doccheck@sgs.com

NO.588 West Jindu Road, Songjiang District, Shanghai, China 201612 t (86-21) 61915666 f (86-21) 61915678 www.sgs.com.cn
 中国·上海·松江区金都西路588号 邮编: 201612 t (86-21) 61915666 f (86-21) 61915678 e sgs.china@sgs.com

Member of the SGS Group (SGS SA)



Front view of sample

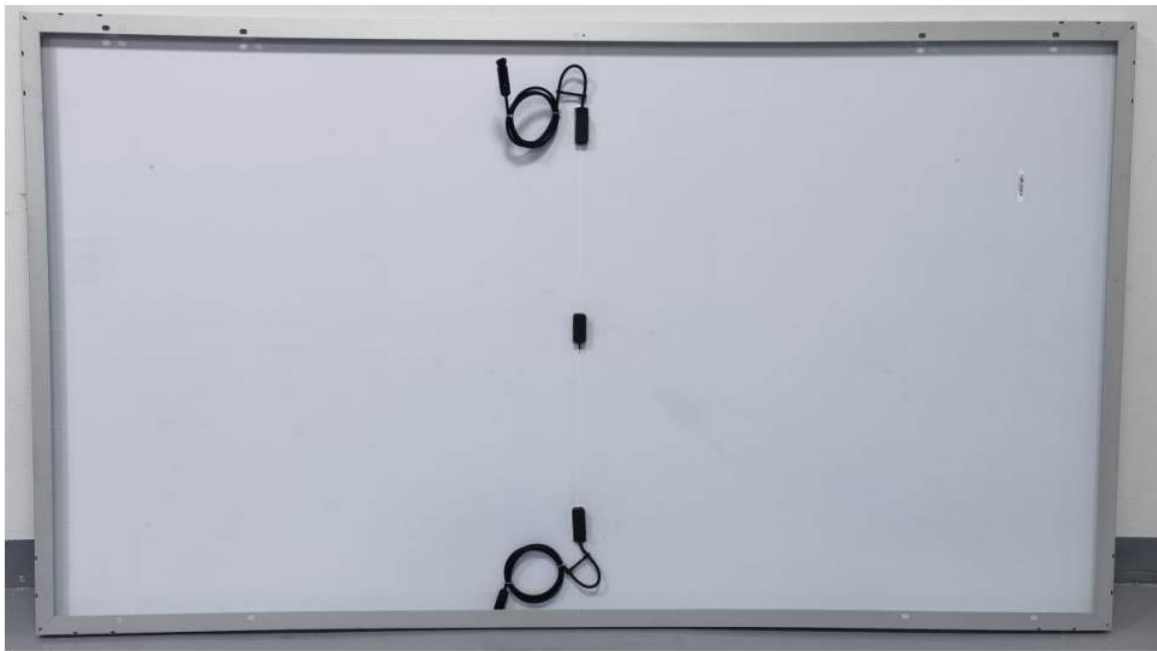

Rear view of sample



Unless otherwise agreed in writing, this document is issued by the Company subject to its General Conditions of Service printed overleaf, available on request or accessible at <http://www.sgs.com/en/Terms-and-Conditions.aspx> and, for electronic format documents, subject to Terms and Conditions for Electronic Documents at <http://www.sgs.com/en/Terms-and-Conditions/Terms-e-Documents.aspx>. Attention is drawn to the limitation of liability, indemnification and jurisdiction issues defined therein. Any holder of this document is advised that information contained hereon reflects the Company's findings at the time of its intervention only and within the limits of Client's instructions, if any. The Company's sole responsibility is to its Client and this document does not exonerate parties to a transaction from exercising all their rights and obligations under the transaction documents. This document cannot be reproduced except in full, without prior written approval of the Company. Any unauthorized alteration, forgery or falsification of the content or appearance of this document is unlawful and offenders may be prosecuted to the fullest extent of the law. Unless otherwise stated the results shown in this test report refer only to the sample(s) tested and such sample(s) are retained for 30 days only.

Attention: To check the authenticity of testing / inspection report & certificate, please contact us at telephone: (86-755) 8307 1443, or email: CN.Doccheck@sgs.com

NO.588 West Jindu Road, Songjiang District, Shanghai, China 201612 t (86-21) 61915666 f (86-21) 61915678 www.sgs.com.cn
 中国·上海·松江区金都西路588号 邮编: 201612 t (86-21) 61915666 f (86-21) 61915678 e sgs.china@sgs.com

Member of the SGS Group (SGS SA)

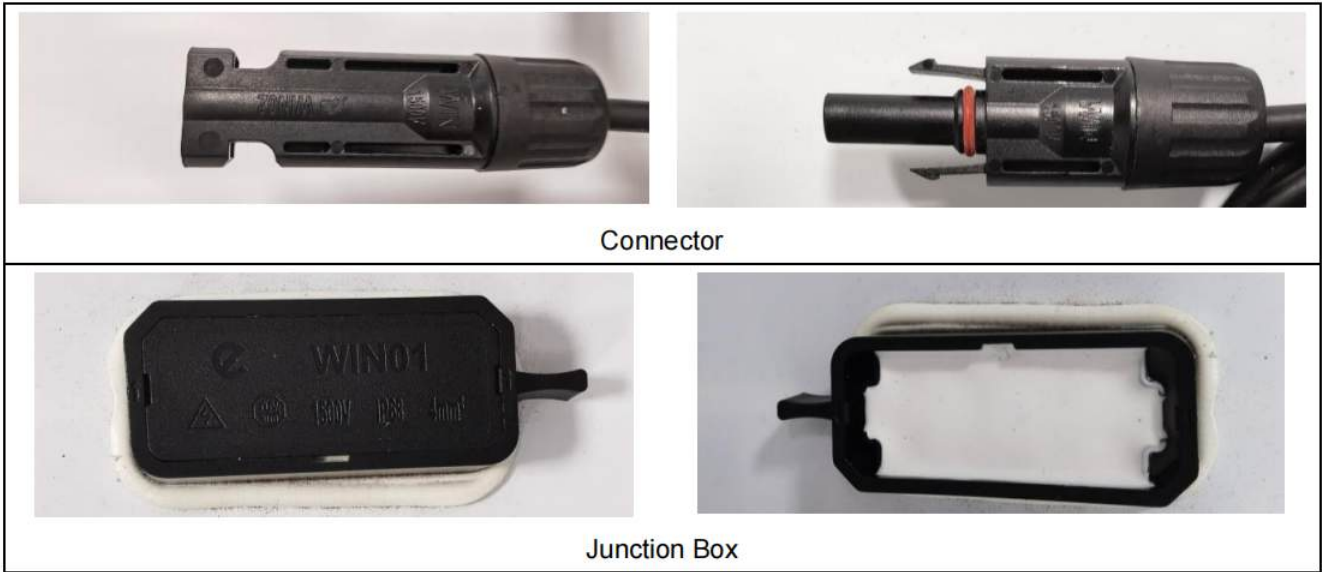

Possible test case verdicts

- Test case does not apply to the test object	N/A
- Test object does meet the requirement	Pass (P)
- Test object does not meet the requirement	Fail (F)

General remarks

The test results presented in this report relate only to the object tested.

This report shall not be reproduced, except in full, without the written approval of the Issuing testing laboratory.

"(See Enclosure #)" refers to additional information appended to the report.

"(See appended table)" refers to a table appended to the report.

Throughout this report a point is used as the decimal separator.

List of test equipment must be kept on file and available for review.

This document is issued by the company under its General Conditions of Service accessible at http://www.sgs.com/terms_and_conditions.htm. Attention is drawn to the limitation of liability, indemnification and jurisdiction issues defined therein. Any holder of this document is advised that information contained hereon reflects the Company's findings at the time of its intervention only and within the limits of Client's instructions, if any. The Company's sole responsibility is to its Client and this document does not exonerate parties to a transaction from exercising all their rights and obligations under the transaction documents. Any unauthorized alteration, forgery or falsification of the content or appearance of this document is unlawful and offenders may be prosecuted to the fullest extent of the law.



Unless otherwise agreed in writing, this document is issued by the Company subject to its General Conditions of Service printed overleaf, available on request or accessible at <http://www.sgs.com/en/Terms-and-Conditions.aspx> and, for electronic format documents, subject to Terms and Conditions for Electronic Documents at <http://www.sgs.com/en/Terms-and-Conditions/Terms-e-Documents.aspx>. Attention is drawn to the limitation of liability, indemnification and jurisdiction issues defined therein. Any holder of this document is advised that information contained hereon reflects the Company's findings at the time of its intervention only and within the limits of Client's instructions, if any. The Company's sole responsibility is to its Client and this document does not exonerate parties to a transaction from exercising all their rights and obligations under the transaction documents. This document cannot be reproduced except in full, without prior written approval of the Company. Any unauthorized alteration, forgery or falsification of the content or appearance of this document is unlawful and offenders may be prosecuted to the fullest extent of the law. Unless otherwise stated the results shown in this test report refer only to the sample(s) tested and such sample(s) are retained for 30 days only.

Attention: To check the authenticity of testing inspection report & certificate, please contact us at telephone: (86-755) 8307 1443, or email: CN.Doccheck@sgs.com

SGS-CSTC Technical Services (Shanghai) Co., Ltd. NO.588 West Jindu Road, Songjiang District, Shanghai, China 201612 t (86-21) 61915666 f (86-21) 61915678 www.sgs.com.cn
 中国·上海·松江区金都西路588号 邮编: 201612 t (86-21) 61915666 f (86-21) 61915678 e sgs.china@sgs.com

Unless otherwise stated: (a) the results shown in this document refer only to the sample(s) tested and (b) such sample(s) are retained for 30 days. This document cannot be reproduced except in full, without prior approval of the company.

Contents:

- 1) The main report
- 2) Appendix 1: List of measurement equipment
- 3) Appendix 2: Statement of the estimated uncertainty of the test results

General product information

The product is photovoltaic (PV) module.

Description of module construction

Model	Cell Type	No. of cells	Dimension [mm]
HS500-MHO	Mono-crystalline	132	2094x1134x35

Technical Data

Type/Model	Voc [V]	Vmp [V]	Isc [A]	Imp [A]	Pmp [W]	Max.System Voltage [V]
HS500-MHO	45.30	37.80	13.83	13.23	500	1500

Type/Model	Module Efficiency [%]	Energy Efficiency Class
HS500-MHO	21.06	A

Supplementary information: Energy efficiency >13.5%: Class A.

Energy efficiency classes	A>13.5%
	13%<B≤13.5%
	12%<C≤13%
	11%<D≤12%
	E<11%



Unless otherwise agreed in writing, this document is issued by the Company subject to its General Conditions of Service printed overleaf, available on request or accessible at <http://www.sgs.com/en/Terms-and-Conditions.aspx> and, for electronic format documents, subject to Terms and Conditions for Electronic Documents at <http://www.sgs.com/en/Terms-and-Conditions/Terms-e-Documents.aspx>. Attention is drawn to the limitation of liability, indemnification and jurisdiction issues defined therein. Any holder of this document is advised that information contained hereon reflects the Company's findings at the time of its intervention only and within the limits of Client's instructions, if any. The Company's sole responsibility is to its Client and this document does not exonerate parties to a transaction from exercising all their rights and obligations under the transaction documents. This document cannot be reproduced except in full, without prior written approval of the Company. Any unauthorized alteration, forgery or falsification of the content or appearance of this document is unlawful and offenders may be prosecuted to the fullest extent of the law. Unless otherwise stated the results shown in this test report refer only to the sample(s) tested and such sample(s) are retained for 30 days only.
 Attention: To check the authenticity of testing /inspection report & certificate, please contact us at telephone: (86-755) 8307 1443, or email: CN.Doccheck@sgs.com
 NO.588 West Jindu Road, Songjiang District, Shanghai, China 201612 t (86-21) 61915666 f (86-21) 61915678 www.sgs.com.cn
 中国·上海·松江区金都西路588号 邮编: 201612 t (86-21) 61915666 f (86-21) 61915678 e sgs.china@sgs.com

Member of the SGS Group (SGS SA)

1. Sampling procedure

<input type="checkbox"/> Random sampling from production (e.g. during factory audit (FA) or inline inspection)
<input type="checkbox"/> Random sampling from the warehouse, container or transportation boxes
<input checked="" type="checkbox"/> Modules have been submitted by the manufacturer/ client without random sampling by SGS

2. Test sample

Sample #	Model Type	Serial Number
01	HS500-MHO	E22711082222801621
02	HS500-MHO	E22711082222801598

3. Test specification and test result

TABLE 1: MQT 01 Visual inspection		
Test Date [YYYY-MM-DD]	:	2022-12-02
Sample #		Nature and position of initial findings
01		No Major visual defects
02		No Major visual defects
Supplementary information: N/A		

TABLE 2: MQT 02 Maximum power determination						
Test Date [YYYY-MM-DD]:		2022-12-02			—	
Test method		<input checked="" type="checkbox"/> indoor		<input type="checkbox"/> outdoor		—
Module temperature [°C]:		Corrected to 25.0			—	
Irradiance [W/m ²]:		Corrected to 1000			—	
Sample #	Voc [V]	Vmp [V]	Isc [A]	Imp [A]	Pmp [W]	FF [%]
01	45.06	37.97	13.79	13.18	500.34	80.55
02	45.13	37.98	13.82	13.17	500.27	80.22
IV Curve:						



Unless otherwise agreed in writing, this document is issued by the Company subject to its General Conditions of Service printed overleaf, available on request or accessible at <http://www.sgs.com/en/Terms-and-Conditions.aspx> and, for electronic format documents, subject to Terms and Conditions for Electronic Documents at <http://www.sgs.com/en/Terms-and-Conditions/Terms-e-Documents.aspx>. Attention is drawn to the limitation of liability, indemnification and jurisdiction issues defined therein. Any holder of this document is advised that information contained hereon reflects the Company's findings at the time of its intervention only and within the limits of Client's instructions, if any. The Company's sole responsibility is to its Client and this document does not exonerate parties to a transaction from exercising all their rights and obligations under the transaction documents. This document cannot be reproduced except in full, without prior written approval of the Company. Any unauthorized alteration, forgery or falsification of the content or appearance of this document is unlawful and offenders may be prosecuted to the fullest extent of the law. Unless otherwise stated the results shown in this test report refer only to the sample(s) tested and such sample(s) are retained for 30 days only.

Attention: To check the authenticity of testing / inspection report & certificate, please contact us at telephone: (86-755) 8307 1443, or email: CN.Doccheck@sgs.com

NO.588 West Jindu Road, Songjiang District, Shanghai, China 201612 t (86-21) 61915666 f (86-21) 61915678 www.sgs.com.cn
 中国·上海·松江区金都西路588号 邮编: 201612 t (86-21) 61915666 f (86-21) 61915678 e sgs.china@sgs.com

Member of the SGS Group (SGS SA)

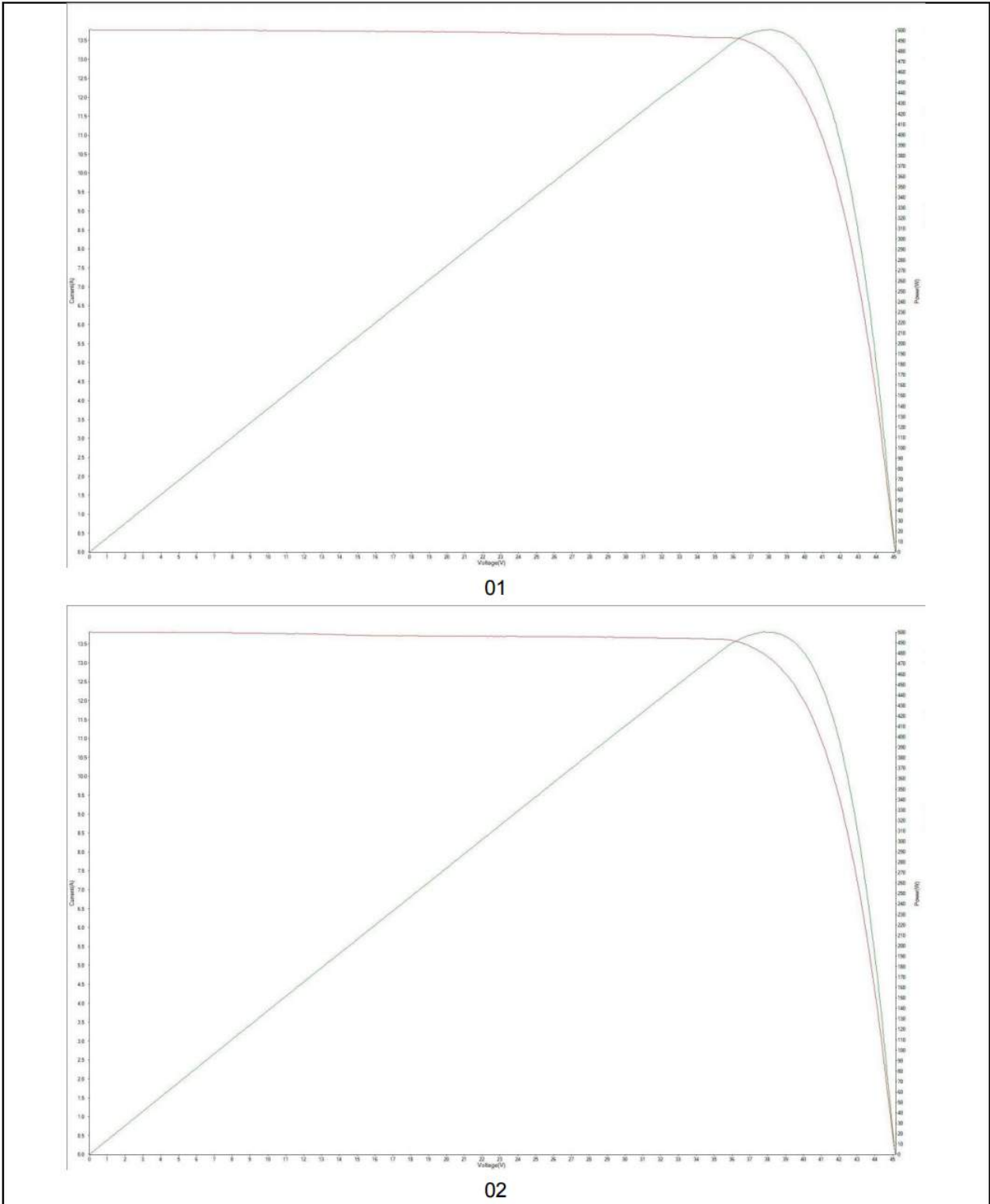

Unless otherwise agreed in writing, this document is issued by the Company subject to its General Conditions of Service printed overleaf, available on request or accessible at <http://www.sgs.com/en/Terms-and-Conditions.aspx> and, for electronic format documents, subject to Terms and Conditions for Electronic Documents at <http://www.sgs.com/en/Terms-and-Conditions/Terms-e-Documents.aspx>. Attention is drawn to the limitation of liability, indemnification and jurisdiction issues defined therein. Any holder of this document is advised that information contained hereon reflects the Company's findings at the time of its intervention only and within the limits of Client's instructions, if any. The Company's sole responsibility is to its Client and this document does not exonerate parties to a transaction from exercising all their rights and obligations under the transaction documents. This document cannot be reproduced except in full, without prior written approval of the Company. Any unauthorized alteration, forgery or falsification of the content or appearance of this document is unlawful and offenders may be prosecuted to the fullest extent of the law. Unless otherwise stated the results shown in this test report refer only to the sample(s) tested and such sample(s) are retained for 30 days only.

Attention: To check the authenticity of testing /inspection report & certificate, please contact us at telephone: (86-755) 8307 1443, or email: CN.Doccheck@sgs.com

NO.588 West Jindu Road, Songjiang District, Shanghai, China 201612 t (86-21) 61915666 f (86-21) 61915678 www.sgs.com.cn
 中国·上海·松江区金都西路588号 邮编: 201612 t (86-21) 61915666 f (86-21) 61915678 e sgs.china@sgs.com

Member of the SGS Group (SGS SA)

Supplementary information: Refer to Appendix 2: Statement of the estimated uncertainty of the test verdicts. The discrepancy between the labelled power value and the measured value shall not exceed the limit of -5%~10%.

TABLE 3: MQT 03 Insulation test					
Test Date [YYYY-MM-DD]		2022-12-03		—	
Test Voltage applied [V]		4000V 1min/1500V 2min		—	
Size of module [m ²]		2.37		—	
Sample #	Measured	Required Resistance	Dielectric breakdown		Result
	MΩ	MΩ	Yes (description)	No	
01	>1000	≥16.88	—	No	P
02	>1000	≥16.88	—	No	P

Supplementary information: Minimum requirement acc. to IEC 61215:2016 is 40 MΩ *m².

TABLE 4: MQT 15 Wet leakage current test					
Test Date [YYYY-MM-DD]		2022-12-03		—	
Test Voltage applied [V]		1500V 2min		—	
Solution resistivity [Ω cm]		2081		—	
Solution temperature [°C]		22.5		—	
Size of module [m ²]		2.37		—	
Sample #	Required Resistance [MΩ]	Measured [MΩ]	Result		
01	≥16.88	>1000	P		
02	≥16.88	>1000	P		

Supplementary information: Minimum requirement acc. to IEC 61215:2016 is 40 MΩ *m².

Appendix 1: List of measurement equipments



Unless otherwise agreed in writing, this document is issued by the Company subject to its General Conditions of Service printed overleaf, available on request or accessible at <http://www.sgs.com/en/Terms-and-Conditions.aspx> and, for electronic format documents, subject to Terms and Conditions for Electronic Documents at <http://www.sgs.com/en/Terms-and-Conditions/Terms-e-Documents.aspx>. Attention is drawn to the limitation of liability, indemnification and jurisdiction issues defined therein. Any holder of this document is advised that information contained hereon reflects the Company's findings at the time of its intervention only and within the limits of Client's instructions, if any. The Company's sole responsibility is to its Client and this document does not exonerate parties to a transaction from exercising all their rights and obligations under the transaction documents. This document cannot be reproduced except in full, without prior written approval of the Company. Any unauthorized alteration, forgery or falsification of the content or appearance of this document is unlawful and offenders may be prosecuted to the fullest extent of the law. Unless otherwise stated the results shown in this test report refer only to the sample(s) tested and such sample(s) are retained for 30 days only.

Attention: To check the authenticity of testing / inspection report & certificate, please contact us at telephone: (86-755) 8307 1443, or email: CN.Doccheck@sgs.com

SGS-CSTC (Shanghai) Technical Services Co., Ltd. NO.588 West Jindu Road, Songjiang District, Shanghai, China 201612 t (86-21) 61915666 f (86-21) 61915678 www.sgs.com.cn
 中国·上海·松江区金都西路588号 邮编: 201612 t (86-21) 61915666 f (86-21) 61915678 e sgs.china@sgs.com

Member of the SGS Group (SGS SA)

Clause	Measurement / testing	Testing / measuring equipment / material used	Equipment ID	Calibration due date
4.1 10.2	Visual inspection	Luminometer	PM6612L	2023.02.14
4.3 10.13	Insulation test	Withstanding voltage/Insulation resistance tester	AN16313HG	2023.08.18
4.6	Performance at STC	Pulsed Solar Simulator	GIV-20A2616	2023.08.02
4.15 10.14	Wet leakage current test	Withstanding voltage/ Insulation resistance tester	AN16313HG	2023.08.18
		Conductive meter	DDS-307	2023.11.01

Appendix 2: Statement of the estimated uncertainty of the test results

The estimated uncertainty fulfils the requirements from the CTL decision sheet DSH 251B / 2009.

----- End of Test Report -----



Unless otherwise agreed in writing, this document is issued by the Company subject to its General Conditions of Service printed overleaf, available on request or accessible at <http://www.sgs.com/en/Terms-and-Conditions.aspx> and, for electronic format documents, subject to Terms and Conditions for Electronic Documents at <http://www.sgs.com/en/Terms-and-Conditions/Terms-e-Documents.aspx>. Attention is drawn to the limitation of liability, indemnification and jurisdiction issues defined therein. Any holder of this document is advised that information contained hereon reflects the Company's findings at the time of its intervention only and within the limits of Client's instructions, if any. The Company's sole responsibility is to its Client and this document does not exonerate parties to a transaction from exercising all their rights and obligations under the transaction documents. This document cannot be reproduced except in full, without prior written approval of the Company. Any unauthorized alteration, forgery or falsification of the content or appearance of this document is unlawful and offenders may be prosecuted to the fullest extent of the law. Unless otherwise stated the results shown in this test report refer only to the sample(s) tested and such sample(s) are retained for 30 days only.
 Attention: To check the authenticity of testing / inspection report & certificate, please contact us at telephone: (86-755) 8307 1443, or email: CN.Doccheck@sgs.com
 NO.588 West Jindu Road, Songjiang District, Shanghai, China 201612 t (86-21) 61915666 f (86-21) 61915678 www.sgs.com.cn
 中国·上海·松江区金都西路588号 邮编: 201612 t (86-21) 61915666 f (86-21) 61915678 e sgs.china@sgs.com

Member of the SGS Group (SGS SA)

CERTIFICATE



of Conformity Low Voltage Directive 2014/35/EU

Registration No.: AN Horay Rights 0001

Report No.: CN22NKK2 001

Holder: HORAY SOLAR CO., LTD
No.30-5,
Yanxin East Road, Huishan District
Wuxi,
214177 Jiangsu
P.R. China

Product: PV Module

Identification: Type Designation:
Max. System Voltage: up to 1500 VDC (Voc at STC):
With 1/2 cut of mono c-Si cells:
HSxxx-MHG (xxx=640-660, in steps of 5, 132 cells)
HSxxx-MHG (xxx=585-600, in steps of 5, 120 cells)
See more type designations in attachment 1.1

This certificate of conformity is based on an evaluation of a sample of the above mentioned product. Technical Report and documentation are at the Licence Holder's disposal. This is to certify that the tested sample is in conformity with Annex I of Council Directive 2014/35/EU, referred to as the Low Voltage Directive. This certificate does not imply assessment of the series-production of the product and does not permit the use of a TÜV Rheinland mark of conformity. The holder of the certificate is authorized to use this certificate in connection with the EC declaration of conformity according to Annex IV of the Directive.

Certification Body

Date 11.05.2022



Dipl.-Ing. (FH) Tim Kirschner

TÜV Rheinland LGA Products GmbH - Tillystraße 2 - 90431 Nürnberg

CE The CE marking may be used if all relevant and effective EC Directives are complied with. CE

TÜV Rheinland
LGA Products GmbH
Tillystraße 2, 90431 Nürnberg

**Attachment to
Registration No.:** AN Horay Rights 0001
Report No.: CN22NKK2 001

Manufacturer: HORAY SOLAR CO., LTD
No.30-5,
Yanxin East Road, Huishan District
Wuxi,
214177 Jiangsu
P.R. China

Scope: Type Designation:
HSxxx-MHG (xxx=535-550, in steps of 5, 110 cells)
HSxxx-MHG (xxx=485-500, in steps of 5, 100 cells)
HSxxx-MHO (xxx=535-560, in steps of 5, 144 cells)
HSxxx-MHO (xxx=495-515, in steps of 5, 132 cells)
HSxxx-MHO (xxx=450-470, in steps of 5, 120 cells)
HSxxx-MHO (xxx=405-420, in steps of 5, 108 cells)
HSxxx-MHL (xxx=445-465, in steps of 5, 144 cells)
HSxxx-MHL (xxx=410-425, in steps of 5, 132 cells)
HSxxx-MHL (xxx=370-385, in steps of 5, 120 cells)

Remarks:
Valid in conjunction with TÜV Rheinland certificate
PV 50542220 0001-0002.

Date: 2022-05-11



Dipl.-Ing. (FH) Tim Kirschner

CERTIFICATE



of Conformity Low Voltage Directive 2014/35/EU

Registration No.: AN **Horay Rights** 0001

Report No.: CN22N95B 001

Holder: **HORAY SOLAR CO., LTD**
No.30-5,
Yanxin East Road, Huishan District
Wuxi,
214177 Jiangsu
P.R. China

Product: PV Module

Identification:

Type Designation:
Max. System Voltage: up to 1500 VDC (Voc at STC):
With 1/2 cut of mono c-Si cell with cell size (Under STC)
HSxxx-MHG-D (xxx=640-660, in steps of 5, 132 cells)
HSxxx-MHG-D (xxx=585-600, in steps of 5, 120 cells)
HSxxx-MHG-D (xxx=535-550, in steps of 5, 110 cells)
See more type designations in attachment 1.1

This certificate of conformity is based on an evaluation of a sample of the above mentioned product. Technical Report and documentation are at the Licence Holder's disposal. This is to certify that the tested sample is in conformity with Annex I of Council Directive 2014/35/EU, referred to as the Low Voltage Directive. This certificate does not imply assessment of the series-production of the product and does not permit the use of a TÜV Rheinland mark of conformity. The holder of the certificate is authorized to use this certificate in connection with the EC declaration of conformity according to Annex IV of the Directive.

Certification Body

Date 24.06.2022



Dipl.-Ing. Matthias Grzam

TÜV Rheinland LGA Products GmbH - Tillystraße 2 - 90431 Nürnberg

CE The CE marking may be used if all relevant and effective EC Directives are complied with. **CE**

TÜV Rheinland
LGA Products GmbH
Tillystraße 2, 90431 Nürnberg

1.1

**Attachment to
Registration No.:** AN Horay Rights 0001
Report No.: CN22N95B 001

Manufacturer: HORAY SOLAR CO., LTD
No.30-5,
Yanxin East Road, Huishan District
Wuxi,
214177 Jiangsu
P.R. China

Scope: Type Designation:
HSxxx-MHG-D (xxx=485-500, in steps of 5, 100 cells)
HSxxx-MHO-D (xxx=535-560, in steps of 5, 144 cells)
HSxxx-MHO-D (xxx=495-515, in steps of 5, 132 cells)
HSxxx-MHO-D (xxx=450-470, in steps of 5, 120 cells)
HSxxx-MHO-D (xxx=405-420, in steps of 5, 108 cells)
HSxxx-MHL-D (xxx=445-465, in steps of 5, 144 cells)
HSxxx-MHL-D (xxx=410-425, in steps of 5, 132 cells)
HSxxx-MHL-D (xxx=370-385, in steps of 5, 120 cells)
With 1/2 cut of mono c-Si cell with cell size (Under BNPI)
HSxxx-MHG-D (xxx=701-723, in steps of 5, 132 cells)
HSxxx-MHG-D (xxx=641-657, in steps of 5, 120 cells)
HSxxx-MHG-D (xxx=586-602, in steps of 5, 110 cells)
HSxxx-MHG-D (xxx=531-548, in steps of 5, 100 cells)
HSxxx-MHO-D (xxx=586-613, in steps of 5, 144 cells)
HSxxx-MHO-D (xxx=542-564, in steps of 5, 132 cells)
HSxxx-MHO-D (xxx=493-515, in steps of 5, 120 cells)
HSxxx-MHO-D (xxx=443-460, in steps of 5, 108 cells)
HSxxx-MHL-D (xxx=487-509, in steps of 5, 144 cells)
HSxxx-MHL-D (xxx=449-465, in steps of 5, 132 cells)
HSxxx-MHL-D (xxx=405-422, in steps of 5, 120 cells)



Date: 2022-06-24

Dipl.-Ing. Matthias Grzam

Zertifikat

Certificate



Zertifikat Nr. Certificate No.
PV Horay Rights

Blatt Sheet
0001

Ihr Zeichen Client Reference
M.G

Unser Zeichen Our Reference
01-Ruanand-CN22NKK2 001

Ausstellungsdatum
11.05.2022

Date of Issue
(day/mo/yr)

Genehmigungsinhaber License Holder

HORAY SOLAR CO., LTD
No.30-5,
Yanxin East Road, Huishan District
Wuxi,
214177 Jiangsu
P.R. China

Fertigungsstätte Manufacturing Plant

Refer to latest revision
of the annex list of factories

Prüfzeichen Test Mark



Geprüft nach Tested acc. to

IEC 61215-1:2021
IEC 61215-1-1:2021
IEC 61215-2:2021
IEC 61730-1:2016
IEC 61730-2:2016
EN IEC 61215-1:2021
EN IEC 61215-1-1:2021
EN IEC 61215-2:2021
EN IEC 61730-1:2018
EN IEC 61730-2:2018

**Zertifiziertes Produkt (Geräteidentifikation)
Certified Product (Product Identification)**

**Lizenzentgelte - Einheit
License Fee - Unit**

PV Module

Type Designation:

Max. System Voltage: up to 1500 VDC (Voc at STC):

With 1/2 cut of mono c-Si cells:

- HSxxx-MHG (xxx=640-660, in steps of 5, 132 cells)
- HSxxx-MHG (xxx=585-600, in steps of 5, 120 cells)
- HSxxx-MHG (xxx=535-550, in steps of 5, 110 cells)
- HSxxx-MHG (xxx=485-500, in steps of 5, 100 cells)
- HSxxx-MHO (xxx=535-560, in steps of 5, 144 cells)
- HSxxx-MHO (xxx=495-515, in steps of 5, 132 cells)
- HSxxx-MHO (xxx=450-470, in steps of 5, 120 cells)
- HSxxx-MHO (xxx=405-420, in steps of 5, 108 cells)
- HSxxx-MHL (xxx=445-465, in steps of 5, 144 cells)
- HSxxx-MHL (xxx=410-425, in steps of 5, 132 cells)
- HSxxx-MHL (xxx=370-385, in steps of 5, 120 cells)

Continued on Page 0002

Dem Zertifikat liegt unsere Prüf- und Zertifizierungsordnung zugrunde.
Das Produkt entspricht den o.g. Anforderungen, die Herstellung wird überwacht.
This certificate is based on our Testing and Certification Regulation. The product
fulfills above mentioned requirements, the production is subject to surveillance.



Zertifizierungsstelle

TÜV Rheinland LGA Products GmbH, Tillystraße 2, 90431 Nürnberg

http://www.tuv.com/safety E-mail: markcheck@tuv.com
Fax: +49 221 806-3935

Dipl.-Ing. (FH) Tim Kirschner

Zertifikat

Certificate



Zertifikat Nr. Certificate No.
PV Horay Rights

Blatt Sheet
0002

Ihr Zeichen Client Reference
M.G

Unser Zeichen Our Reference
01-Ruanand-CN22NKK2

Ausstellungsdatum
001 11.05.2022

Date of Issue
(day/mo/yr)

Genehmigungsinhaber License Holder

HORAY SOLAR CO., LTD
No.30-5,
Yanxin East Road, Huishan District
Wuxi,
214177 Jiangsu
P.R. China

Fertigungsstätte Manufacturing Plant

Refer to latest revision
of the annex list of factories

Prüfzeichen Test Mark



IEC 61215
IEC 61730
Regular Production
Surveillance

www.tuv.com
ID 1111253582

Geprüft nach Tested acc. to

IEC 61215-1:2021
IEC 61215-1-1:2021
IEC 61215-2:2021
IEC 61730-1:2016
IEC 61730-2:2016
EN IEC 61215-1:2021
EN IEC 61215-1-1:2021
EN IEC 61215-2:2021
EN IEC 61730-1:2018
EN IEC 61730-2:2018

**Zertifiziertes Produkt (Geräteidentifikation)
Certified Product (Product Identification)**

PV Module

**Lizenzentgelte - Einheit
License Fee - Unit**

Continuation of Page 0001

Remarks:

Class II acc. to IEC 61140
Fire Rating: Class C (according to UL 790)
Design Load/ Safety Factors: 3600 Pa / 1.5 (downward)
1600 Pa / 1.5 (upward)

Conditions:

The product test is voluntarily according to technical regulations. Any change of the design, materials, components or processing may require the repetition of some of the qualification tests in order to retain type approval.

The certificate is valid until 10 May 2027.

Dem Zertifikat liegt unsere Prüf- und Zertifizierungsordnung zugrunde.
Das Produkt entspricht den o.g. Anforderungen, die Herstellung wird überwacht.
This certificate is based on our Testing and Certification Regulation. The product fulfills above mentioned requirements, the production is subject to surveillance.



Zertifizierungsstelle

TÜV Rheinland LGA Products GmbH, Tillystraße 2, 90431 Nürnberg

http://www.tuv.com/safety E-mail: markcheck@tuv.com
Fax: +49 221 806-3935

Dipl.-Ing. (FH) Tim Kirschner

Anlage Fertigungsstättenliste
/Attachment List of Factories



PV Horay Rights 001

1 HORAY SOLAR CO., LTD
No.30-5,
Yanxin East Road, Huishan District
Wuxi,
214177 Jiangsu
P.R. China



Dieser Anhang ersetzt den Vorgänger vom/
This annex replaces the previous annex dated

Datum / Date 11.05.2022



Zertifizierungsstelle
/ Certification Body

A handwritten signature in blue ink, appearing to be "Tim Kirschner".

Dipl.-Ing. (FH) Tim Kirschner

Zertifikat *Certificate*

Zertifikatsnummer Certificate No.:

PV 50653396 0001

Berichtsnummer Report No.:

CN24204G 001

Genehmigungsinhaber License Holder:

HORAY SOLAR CO., LTD
No.30-5,
Yanxin East Road, Huishan District
Wuxi,
214177 Jiangsu
P.R. China

Fertigungsstätte Manufacturing Site:

HORAY SOLAR CO., LTD
No.30-5,
Yanxin East Road, Huishan District
Wuxi,
214177 Jiangsu
P.R. China

Prüfzeichen Test Mark:

Geprüft nach Tested according to:

IEC 61215-1:2021
IEC 61215-1-1:2021
IEC 61215-2:2021
IEC 61730-1:2023
IEC 61730-2:2023
EN IEC 61215-1:2021
EN IEC 61215-1-1:2021
EN IEC 61215-2:2021
EN IEC 61730-1:2018
EN IEC 61730-2:2018

Geräteidentifikation
Product Identification
Produkt: PV Module

Product:
Modell: Modelle sind auf nächste(r) Seite(n) gelistet

Type: *Type designation(s) are listed on the next page(s)*
Technische Daten: Class II acc. to IEC 61140

Technical Data: For other ratings, refer to the test report.

Gültig bis: 2029-11-10

Date of expiry:
Gültig ab: 2024-11-11

Valid from:
Ausstellungsdatum: 2024-11-11

Date of issue:
Zertifizierungsstelle:
Certification body:

Angela Yao



Dem Zertifikat liegt unsere Prüf- und Zertifizierungsordnung zugrunde.
Das Produkt entspricht den o.g. Anforderungen, die Herstellung wird überwacht.
This certificate is based on our Testing and Certification Regulation. The product fulfills above mentioned requirements, the production is subject to surveillance.

TÜV Rheinland LGA Products GmbH, Tillystraße 2, 90431 Nürnberg
<http://www.tuv.com/safety> E-mail: markcheck@tuv.com

Fax: +49 221 806-3935

Zertifikat *Certificate*

Zertifikatsnummer *Certificate No.:*

PV 50653396 0001

Berichtsnummer *Report No.:*

CN24204G 001

Produkt *Product:* PV Module

Modell *Type:*

Bezeichnung *Designation:*

Max. system voltage: up to 1500 VDC (Voc at STC):

With 1/2 cut of mono N-type c-Si cell (Under STC):

HSxxxTC-MHG-D (xxx=670-700, in steps of 5, 132 cells)

HSxxxTC-MHG-D (xxx=610-635, in steps of 5, 120 cells)

HSxxxTC-MHG-D (xxx=560-580, in steps of 5, 110 cells)

HSxxxTC-MHG-D (xxx=550-570, in steps of 5, 108 cells)

HSxxxTC-MHG-D (xxx=510-530, in steps of 5, 100 cells)

HSxxxTC-MHA-D (xxx=575-610, in steps of 5, 144 cells)

HSxxxTC-MHA-D (xxx=530-560, in steps of 5, 132 cells)

HSxxxTC-MHA-D (xxx=480-510, in steps of 5, 120 cells)

HSxxxTC-MHA-D (xxx=425-455, in steps of 5, 108 cells)

HSxxxTC-MHB-D (xxx=590-620, in steps of 5, 144 cells)

HSxxxTC-MHB-D (xxx=540-570, in steps of 5, 132 cells)

HSxxxTC-MHB-D (xxx=490-520, in steps of 5, 120 cells)

HSxxxTC-MHB-D (xxx=445-475, in steps of 5, 108 cells)

HSxxxTC-MHC-D (xxx=585-630, in steps of 5, 132 cells)

HSxxxTC-MHC-D (xxx=535-570, in steps of 5, 120 cells)

HSxxxTC-MHC-D (xxx=480-515, in steps of 5, 108 cells)

HSxxxTC-MHC-D (xxx=425-455, in steps of 5, 96 cells)

HSxxxTC-MHO-D (xxx=560-590, in steps of 5, 144 cells)

HSxxxTC-MHO-D (xxx=515-540, in steps of 5, 132 cells)

HSxxxTC-MHO-D (xxx=470-490, in steps of 5, 120 cells)

HSxxxTC-MHO-D (xxx=420-440, in steps of 5, 108 cells)

HSxxxTC-MHD-D (xxx=610-650, in steps of 5, 144 cells)

HSxxxTC-MHD-D (xxx=560-590, in steps of 5, 132 cells)

HSxxxTC-MHD-D (xxx=510-540, in steps of 5, 120 cells)

HSxxxTC-MHD-D (xxx=460-485, in steps of 5, 108 cells)

With 1/2 cut of mono Perc c-Si cell (Under STC):

HSxxx-MHG-D (xxx=640-660, in steps of 5, 132 cells)

HSxxx-MHG-D (xxx=585-600, in steps of 5, 120 cells)

HSxxx-MHG-D (xxx=535-550, in steps of 5, 110 cells)

HSxxx-MHG-D (xxx=485-500, in steps of 5, 100 cells)

HSxxx-MHO-D (xxx=535-560, in steps of 5, 144 cells)

HSxxx-MHO-D (xxx=495-515, in steps of 5, 132 cells)

HSxxx-MHO-D (xxx=450-470, in steps of 5, 120 cells)

HSxxx-MHO-D (xxx=405-420, in steps of 5, 108 cells)

HSxxx-MHL-D (xxx=445-465, in steps of 5, 144 cells)

HSxxx-MHL-D (xxx=410-425, in steps of 5, 132 cells)

HSxxx-MHL-D (xxx=370-385, in steps of 5, 120 cells)

With 1/2 cut of mono N-type c-Si cell (Under BNPI):

HSxxxTC-MHG-D (xxx=737,743,748,754,759,765,770, 132 cells)

HSxxxTC-MHG-D (xxx=671,677,682,688,693,699, 120 cells)

HSxxxTC-MHG-D (xxx=616,622,627,633,638, 110 cells)

HSxxxTC-MHG-D (xxx=605,610.5,616,621.5,627, 108 cells)

HSxxxTC-MHG-D (xxx=561,567,572,578,583, 100 cells)

HSxxxTC-MHA-D (xxx=621,626,631,637,642,648,653,658, 144 cells)

HSxxxTC-MHA-D (xxx=572,577,583,588,594,599,604, 132 cells)

HSxxxTC-MHA-D (xxx=518,523,529,534,540,545,550, 120 cells)



Zertifikat *Certificate*

Zertifikatsnummer *Certificate No.:*

PV 50653396 0001

Berichtsnummer *Report No.:*

CN24204G 001

Produkt *Product:* PV Module

Modell *Type:*

Bezeichnung *Designation:*

HSxxxTC-MHA-D (xxx=459,464,469,475,480,486,491, 108 cells)
 HSxxxTC-MHB-D (xxx=649,655,660,666,671,677,682, 144 cells)
 HSxxxTC-MHB-D (xxx=594,599.5,605,610.5,616,621.5,627, 132 cells)
 HSxxxTC-MHB-D (xxx=539,544.5,550,555.5,561,566.5,572, 120 cells)
 HSxxxTC-MHB-D (xxx=489.5,495,500.5,506,511.5,517,522.5, 108 cells)
 HSxxxTC-MHC-D (xxx=644,649,655,660,666,671,677,682,688,693, 132 cells)
 HSxxxTC-MHC-D (xxx=589,594,600,605,611,616,622,627, 120 cells)
 HSxxxTC-MHC-D (xxx=528,534,539,545,550,556,561,567, 108 cells)
 HSxxxTC-MHC-D (xxx=468,473,479,484,490,495,501, 96 cells)
 HSxxxTC-MHO-D (xxx=611,616,622,627,633,638,644, 144 cells)
 HSxxxTC-MHO-D (xxx=562,568,573,578,584,589, 132 cells)
 HSxxxTC-MHO-D (xxx=513,518,524,529,535, 120 cells)
 HSxxxTC-MHO-D (xxx=458,464,469,475,481, 108 cells)
 HSxxxTC-MHD-D (xxx=671,677,682,688,693,699,704,710,715, 144 cells)
 HSxxxTC-MHD-D (xxx=616,622,627,633,638,644,649, 132 cells)
 HSxxxTC-MHD-D (xxx=561,567,572,578,583,589,594, 120 cells)
 HSxxxTC-MHD-D (xxx=506,512,517,523,528,534, 108 cells)
 With 1/2 cut of mono Perc c-Si cell (Under BNPI):
 HSxxx-MHG-D (xxx=701,706,712,717,723, 132 cells)
 HSxxx-MHG-D (xxx=641,646,652,657, 120 cells)
 HSxxx-MHG-D (xxx=586,591,597,602, 110 cells)
 HSxxx-MHG-D (xxx=531,537,542,548, 100 cells)
 HSxxx-MHO-D (xxx=586,591,597,602,608,613, 144 cells)
 HSxxx-MHO-D (xxx=542,548,553,558,564, 132 cells)
 HSxxx-MHO-D (xxx=493,498,504,509,515, 120 cells)
 HSxxx-MHO-D (xxx=443,449,454,460, 108 cells)
 HSxxx-MHL-D (xxx=487,493,498,504,509, 144 cells)
 HSxxx-MHL-D (xxx=449,454,460,465, 132 cells)
 HSxxx-MHL-D (xxx=405,411,416,422, 120 cells)
 xxx represents output power at STC in Wp

Remarks:

Fire Rating: Class A (according to UL 790)

Design Load / Safety Factors: 3600 Pa / 1.5 (downward)
 1600 Pa / 1.5 (upward)

Conditions:

The product test is voluntarily according to technical regulations. Any change of the design, materials, components or processing may require the repetition of some of the qualification tests in order to retain type approval.





ACHYRA[®]

Soluzioni Energetiche Sostenibili

Milano - Nola - HongKong - Guangzhou

MANUALI

HORAY SOLAR

HORAY

Horay Installation Manual

Single Glass

EXCELLENT PV MODULE MANUFACTURER





HORAY SOLAR PV MODULES

Installation and User Manual

Revision date: 1 Jan, 2024 | Applicable for IEC certified products

This manual applies to photovoltaic modules ("PV modules", also commonly known as solar panels) manufactured by **HoRay Solar** Co., Ltd. ("**HoRay Solar**"), and is explicitly written for qualified professionals ("Installer" or "Installers"), including without limitation licensed electricians and RAL Certified PV Installers.

INTRODUCTION

Thank you for choosing **HoRay Solar** as your PV module provider. We appreciate your business! This manual contains important information pertaining to the electrical and mechanical installation and maintenance of PV modules, and includes safety information that you must read carefully and be familiar with before handling, installing, and/or maintaining **HoRay Solar** PV modules.

HoRay Solar does not assume responsibility and expressly disclaims liability for losses, damages, or expenses arising out of, or in any way connected with this Installation and User Manual. **HoRay Solar** assumes no responsibility for any infringement of patents or other rights of third parties, which may result from using **HoRay Solar** PV modules. No license is granted expressly or by implication or under any patent or patent rights. The information in this manual is believed to be reliable, but does not constitute an expressed or implied warranty. **HoRay Solar** reserves the right to make changes to its PV modules and other products, their specifications, or this manual without prior notice.

HoRay Solar and its subsidiaries are not liable for any damages caused by inappropriate installation, use, or maintenance of **HoRay Solar** PV modules, including without limitation damages, losses, and expenses caused by nonobservance of the instructions of this manual or caused by or in connection with products of other manufacturers.

HoRay Solar PV modules are designed to meet the requirements for the standards IEC 61215 and IEC 61730, application class A. Modules rated for use in this application class may be used in systems operating at greater than 50 VDC or 240 W, where general contact access is anticipated. Modules qualified for safety through IEC 61730-1 and IEC 61730-2 and within this application class are considered to meet the requirements for safety class II. In the course of the PV module certification process, the compliance of this manual with the certification requirements has been

verified by an independent certification laboratory. This Installation and User Manual is available in different languages. In cases of discrepancy between versions, the English language version shall control. Failure to comply with the requirements listed in this manual will invalidate the Limited Warranty for PV Modules as provided by **HoRay Solar** at the time of sale to the direct customer. Additional recommendations are provided to enhance safety practices and performance results. Please provide a copy of this manual to the PV system owner for their reference, and inform them of all relevant aspects of safety, operation, and maintenance.

SAFETY

General

You must understand and follow all applicable local, state, and federal regulations and standards for building construction, electrical design, fire, and safety. It is imperative to check with local authorities to determine the applicable permitting requirements before attempting to install or maintain PV modules.



Rooftop PV systems should only be installed on dwellings that have undergone a formal analysis by a certified building specialist or engineer to confirm their structural integrity and ability to support the additional weight of PV system components, including PV modules.

For your safety, never work on a rooftop until all necessary safety precautions have been identified and implemented. This includes, but is not limited to, ensuring fall protection measures are in place, using proper ladders or stairways, and wearing personal protective equipment (PPE).

Avoid installing or handling PV modules under adverse conditions such as strong or gusty winds, and wet or frosted roof surfaces, as these can pose significant safety risks.

The flat-plate PV module is constructed from a laminated assembly of solar cells encapsulated within an insulating material. This assembly is protected by a rigid glass surface on one side and an insulated substrate on the other. The entire assembly is supported by an aluminum frame, which also serves as the mounting structure for the module. Refer to Figure 1 for a visual representation of the PV module components.

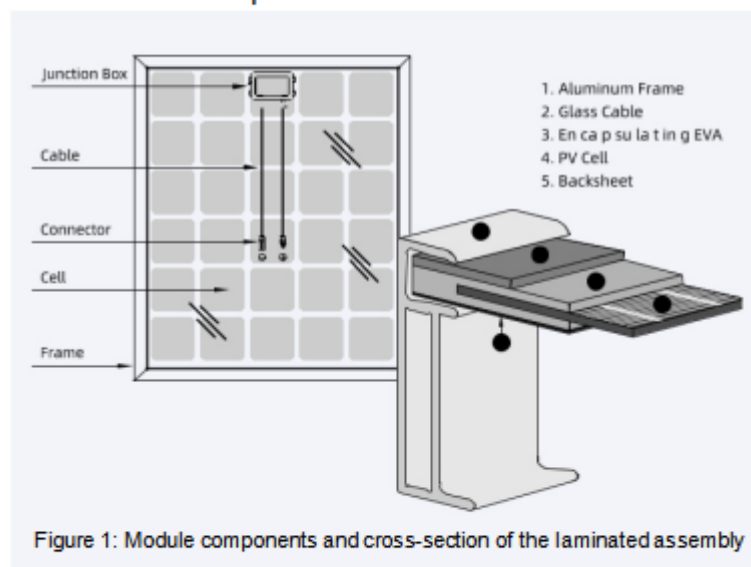

Figure 1: Module components and cross-section of the laminated assembly

Electrical



PV modules can produce current and voltage when exposed to light of any intensity. Electrical current increases with higher light intensity. DC voltage of 30 Volts or higher is potentially lethal. Contacting the live circuitry of a PV system operating under light can result in lethal electric shock.

De-energize PV modules by removing them entirely from light or by covering their front surface with an opaque material. Regard the safety regulations for live electrical equipment when working with modules that are exposed to any light. Use insulated tools and do not wear metallic jewelry while working with PV modules.

In order to avoid arcing and electrical shock, do not disconnect electrical connections under load. Faulty connections can also result in arcing and electrical shock. Keep connectors dry and clean, and ensure that they are in proper working condition. Never insert metallic objects into the connectors, or modify them in any way in order to secure an electrical connection.

Do not touch or handle PV modules with broken glass, separated frames or a damaged backsheet unless the PV modules are first disconnected and you are wearing proper PPE. Avoid handling PV modules when they are wet unless cleaning the PV modules as directed in this manual. Never touch electrical connections that are wet without protecting yourself with insulated gloves.

Transport and Handling

HoRay Solar PV modules must be transported in the supplied packaging only and kept in the packaging until they are ready to be installed. Protect pallets against movement and exposure to damage during transportation. Secure pallets from falling over. Do not exceed the maximum height of pallets to be stacked, as indicated on the pallet packaging. Store pallets in a cool and dry location until the PV modules are ready to be unpackaged.

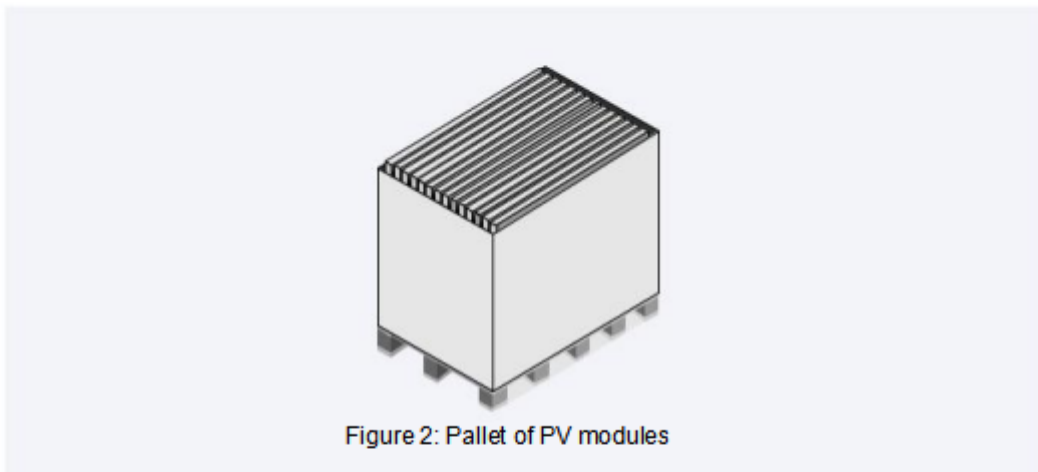

Figure 2: Pallet of PV modules

HoRay Solar PV modules are heavy, and should be handled with care. PV modules shall be handled at the frame; never use the junction box or cables as a grip. Do not exert mechanical stress on the cables. Never step on PV modules or drop or place heavy objects on them. Be careful when placing PV modules on hard surfaces, and secure them from falling. Broken glass can result in personal injury. PV modules with broken glass cannot be repaired and must not be used. Broken or damaged PV modules must be handled carefully and disposed of properly.

For unpacking PV modules from the **HoRay Solar** supplied packaging, first remove the pallet lid (after removing securing straps, if provided). Remove PV modules one at a time by sliding them up the channel in the package (see Figure 3). You may need to secure the remaining PV modules in the pallet packaging to prevent them from falling over.

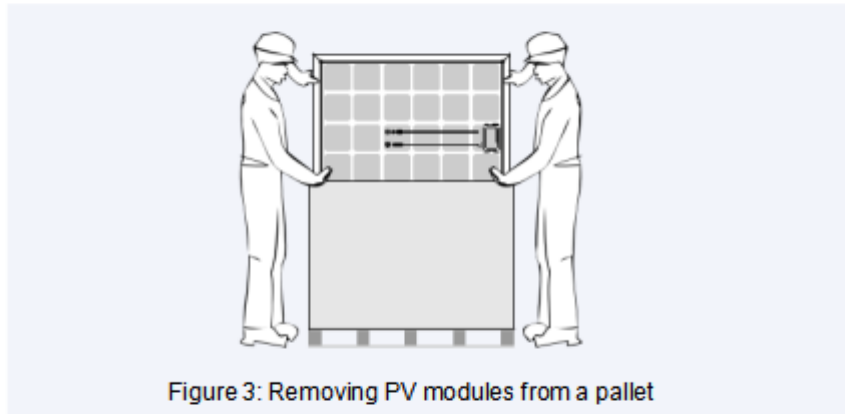

Figure 3: Removing PV modules from a pallet

Check PV modules for damage due to transportation before they are installed; do not install damaged modules. Contact the company you purchased the **HoRay Solar** PV modules from in order to obtain information on making claims for defective PV modules.

PV module surfaces are susceptible to damage that could affect the performance or safety of the PV module; do not damage or scratch the PV module surfaces, and do not apply paint or adhesive to any of the surfaces, including the frame. For your safety, do not disassemble or modify **HoRay Solar** PV modules in any way. Doing so may degrade performance or cause irreparable damage and will void any applicable warranties.

If it is necessary to store PV modules prior to installation, the PV modules should remain inside the packaging and protected from exposure that could compromise the durability of the packaging.

Fire

HoRay Solar PV Modules have a Class C fire resistance rating in accordance with the IEC 61730-2 certification. When PV modules are mounted on rooftops, the roof must have a fire resistant covering suitable for this application. PV modules are electrical generating devices that may affect the fire safety of a building. The use of improper installation methods and/or defective parts may result in the unexpected occurrence of an electrical arc during operation. In order to mitigate the risk of fire in this event, PV modules should not be installed near flammable liquids, gases, or locations with hazardous materials.

In the event of a fire, PV modules may continue to produce a dangerous voltage, even if they have been disconnected from the inverter, have been partly or entirely destroyed, or the system wiring has been compromised or destroyed. In the event of fire, inform the fire crew about the particular hazards from the PV system, and stay away from all elements of the PV system during and after a fire until the necessary steps have been taken to make the PV system safe.

APPLICATION INFORMATION

Application Restrictions

HoRay Solar PV modules must be mounted on appropriate mounting structures positioned on suitable buildings, the ground, or other structures suitable for PV modules (e.g. carports, building facades or PV trackers). PV modules must not be mounted on moving vehicles of any kind. **HoRay Solar** PV modules must not be installed in locations where they could be submerged in water.

HoRay Solar PV modules must not be sited in locations where aggressive substances such as salt or salt-water, or any other type of corrosive agent, could affect the safety and/or performance of the PV modules. Although some types of **HoRay Solar** PV modules have passed the IEC 61701 salt-mist corrosion test with a salt concentration of 5% by weight, galvanic corrosion can occur between the aluminum frame of the PV module and mounting or grounding hardware if such hardware is comprised of dissimilar metals. **HoRay Solar** recommends that only stainless steel and aluminum metal directly contact PV modules in seaside installations to limit corrosion.

Artificially concentrated light must not be directed on **HoRay Solar** PV modules. Design Recommendations: **HoRay Solar** recommends that PV Modules be mounted at a minimum tilt angle of 10 degrees to allow for proper self-cleaning from normal rain showers. Partial or complete shading of a PV module or modules can significantly reduce system performance. **HoRay Solar** recommends minimizing the amount of shade throughout the year to increase the amount of energy produced by the PV modules.

Lightning protection is recommended for PV systems that are to be installed in locations with a high probability of lightning strikes.

High system voltages could be induced in the event of an indirect lightning strike, which could cause damage to PV system components. The open area of wire loops should be minimized, as shown in Figure 4, in order to reduce the risk

HoRay recommends that modules used or installed should be 2000 meters (altitude) at most of lightning induced voltage surges.

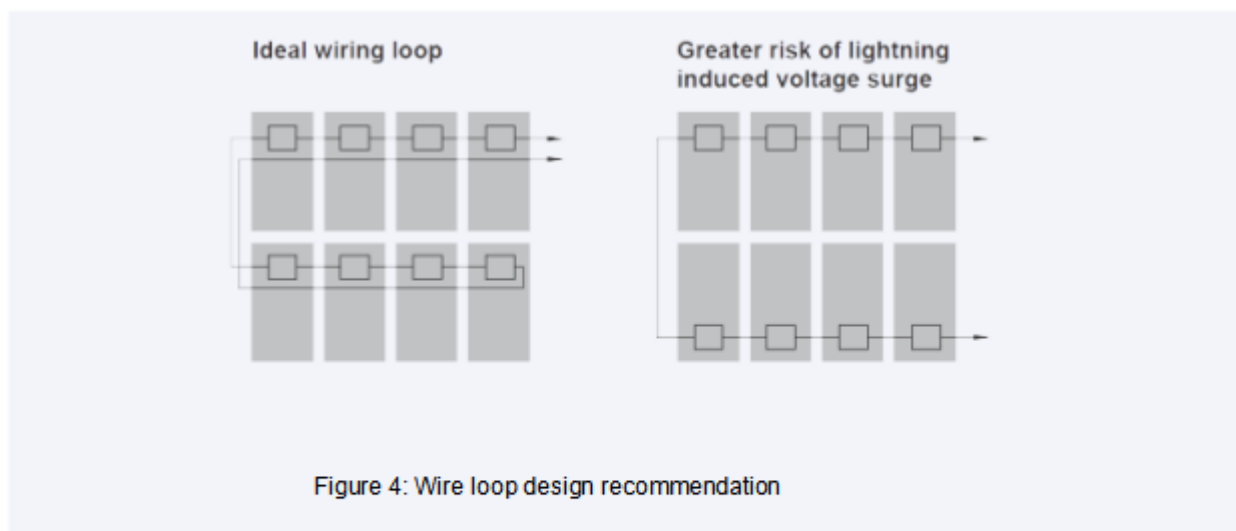

ELECTRICAL INSTALLATION

Electrical Configuration

Under normal conditions, a photovoltaic module is likely to experience conditions that produce more current and/or voltage than reported at Standard Test Conditions (STC: 1000 W/m², AM 1.5, and 25°C cell temperature). The short-circuit current (ISC) should be multiplied by a factor of 1.25 and the open-circuit voltage (VOC) should be multiplied by a factor of up to 1.25 based on the lowest ambient temperature recorded for the installation location when determining component voltage ratings, conductor current ratings, fuse sizes, and size of controls connected to the PV output.

Voltages are additive when PV modules are connected directly in series, and module currents are additive when PV modules are connected directly in parallel, as illustrated in Figure 5. PV modules with different electrical characteristics must not be connected directly in series. The use of suitable third-party electronic devices connected to PV modules may enable different electrical connections and must be installed according to the manufacturer's specified instructions.

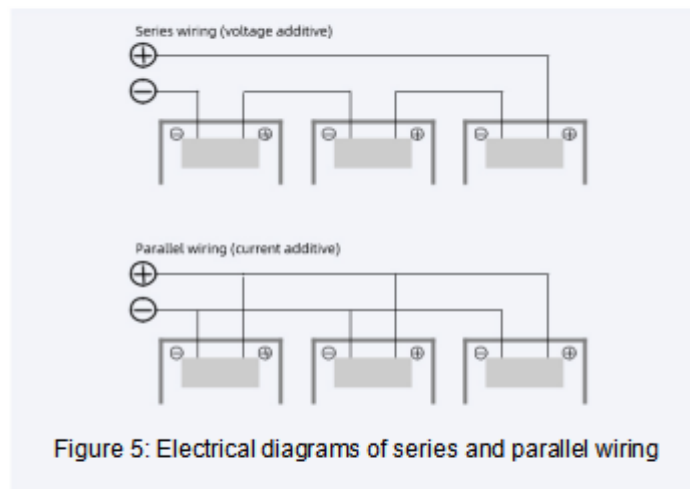

The maximum number of PV modules that can be connected in a series string must be calculated in accordance with applicable regulations in such a way that the specified maximum system voltage of the PV module and all other electrical DC components will not be exceeded in open-circuit operation at the lowest temperature expected at the PV system location.

An appropriately rated overcurrent protection device must be used when the reverse current could exceed the value of the maximum fuse rating of the module. An over current protection device and anti-reflection diode module are required for each series string if more than two series strings are connected in parallel, and reverse polarity is forbidden.

Cables and Wiring

HoRay Solar PV modules are provided with two(2) stranded, sunlight resistant output cables that are terminated with PV connectors ready for most installations. The positive (+) terminal has a female connector while the negative (-) terminal has a male connector. The module wiring is intended for series connections [i.e. female (+) to male (-) interconnections], but can also be used to connect suitable third-party electrical devices that may have alternative wiring configurations so long as the manufacturer's instructions are followed.

Use field wiring with suitable cross-sectional areas that are approved for use at the maximum short-circuit current of the PV module. **HoRay Solar** recommends installers use only sunlight resistant cables qualified for direct current (DC) wiring in PV systems. The minimum wire size should be 4m m² .

Table 1: Required minimum field wiring specifications

	Testing Standard	Wire Size	Temperature Rating
Required Minimum Field Wiring	EN 50618	4m m 2	-40°C to +90°C

Cables should be fixed to the mounting structure in such a way that mechanical damage of the cable and/or the module is avoided. Do not apply stress to the cables. Do not bend cables to a bending radius of less than 40mm. For fixing, use appropriate means, such as sunlight resistant cable ties and/or wire management clips specifically designed to attach to the PV module frame. While the cables are sunlight resistant and waterproof, where possible, avoid direct sunlight exposure and water immersion of the cables.

Connectors



Keep connectors dry and clean, and ensure that connector caps are hand tight before connecting the modules. Do not attempt making an electrical connection with wet, soiled, or otherwise faulty connectors. Avoid sunlight exposure and water immersion of the connectors. Avoid connectors resting on the ground or roof surface.

Faulty connections can result in arcs and electrical shock. Check that all electrical connections are securely fastened. Make sure that all locking connectors are fully engaged and locked.

Modules must not be interconnected using connectors from different manufacturers and/or of different types. If modules having such different connectors need to be interconnected, a qualified professional may replace connectors according to the manufacturer's specified instructions such that an interconnection can be made with connectors from the same manufacturer and the same type.

The Suppliers and types of connectors should be in accordance with the Standard IEC 62852. For more details, please see the CDF.

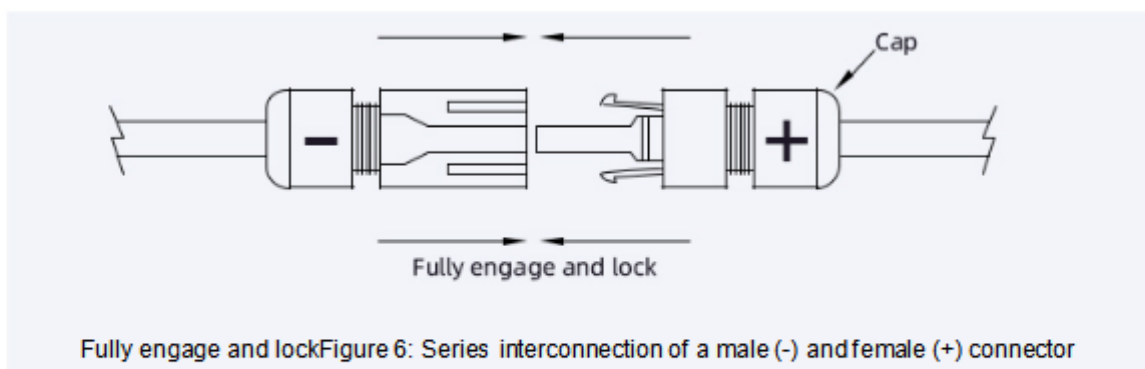

Bypass Diodes

The junction boxes used with **HoRay Solar** PV modules (not Smart Hot Spot Free module) contain bypass diodes wired in parallel with the PV cell strings. In the case of partial shading, the diodes bypass the current generated by the non-shaded cells, thereby limiting module heating and performance losses. Bypass diodes are not over current protection devices.

Bypass diodes divert current from the cell strings in the event of partial shading. See Figure 7-1 for a diagram showing how the cell strings are electrically connected with the diodes.

Every piece of cells from HoRay Smart Hot Spot Free module parallels a diode. If a cell is covered by shade or an exception occurs, the paralleled diode can bypass this cell, thereby avoiding a hot spot and retaining the maximum power output.

Bypass diodes divert current from a cell in the event of partial shading. See Figure 7-2 for a diagram showing how the cells are electrically connected with the diodes.

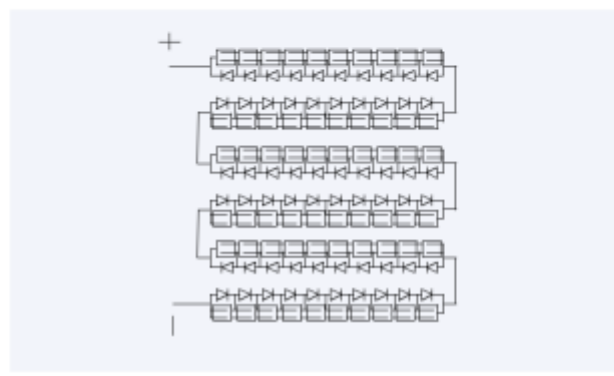
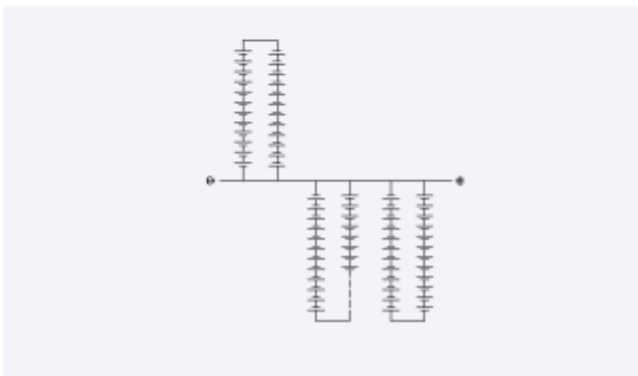

Figure 7-1: Electrical circuitry of cells and bypass diodes

Figure 7-2: Electrical circuitry of cells and bypass diodes

In the event of a known or suspected diode failure, installers or maintenance providers should contact the company from which the PV modules were purchased. **Never attempt to open the junction box of a HoRay Solar PV module yourself.**

Grounding

The frame of the PV module, as well as any exposed non-current-carrying metal parts of fixed equipment that are able to become energized by the PV system, must be connected to the equipment grounding conductor (EGC) in order to prevent electrical shock. Even when applicable regulations, code requirements, and standards do not require safety-related grounding, **HoRay Solar** recommends grounding all PV module frames in order to ensure the voltage between electrically conductive equipment and earth ground is zero in all circumstances.

Proper equipment grounding is achieved by bonding all exposed non-current-carrying metal equipment continuously to one another using an appropriately sized EGC or racking system that can be used for integrated grounding (see Option B in Grounding Methods below).

HoRay Solar PV modules employ a coated aluminum frame for corrosion resistance. In order to properly ground the module frame, the coating must be penetrated.

The potential for corrosion due to the electrochemical action between dissimilar metals in contact is minimized if the electrochemical voltage potential between the dissimilar metals is low. The grounding method must not result in the direct contact of dissimilar metals with the aluminum frame of the PV module that will result in galvanic corrosion. An addendum to UL Standard 1703 "Flat Plate Photovoltaic Modules and Panels" recommends metal combinations not exceed an electrochemical potential difference of 0.5 Volts.

The frame rails have pre-drilled holes marked with a grounding sign, as illustrated in Figure 8. These holes should be used for grounding purposes and must not be used for mounting the PV modules. Do not drill additional holes into the frame rails.

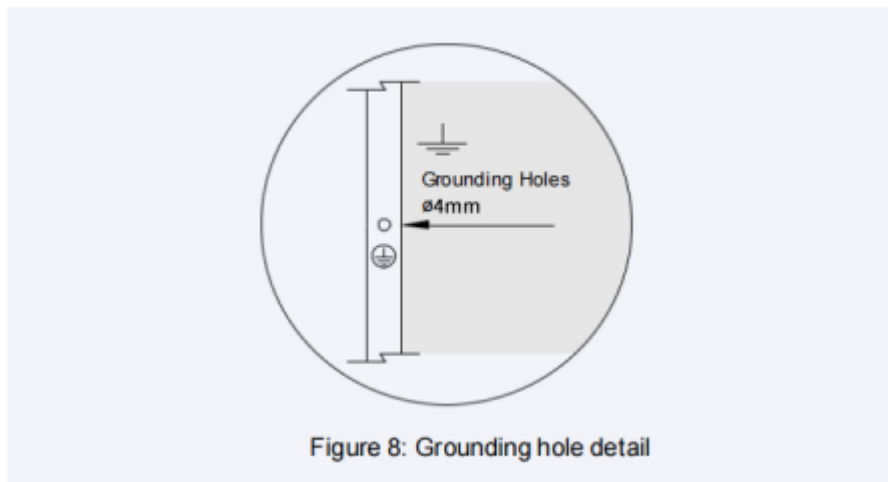
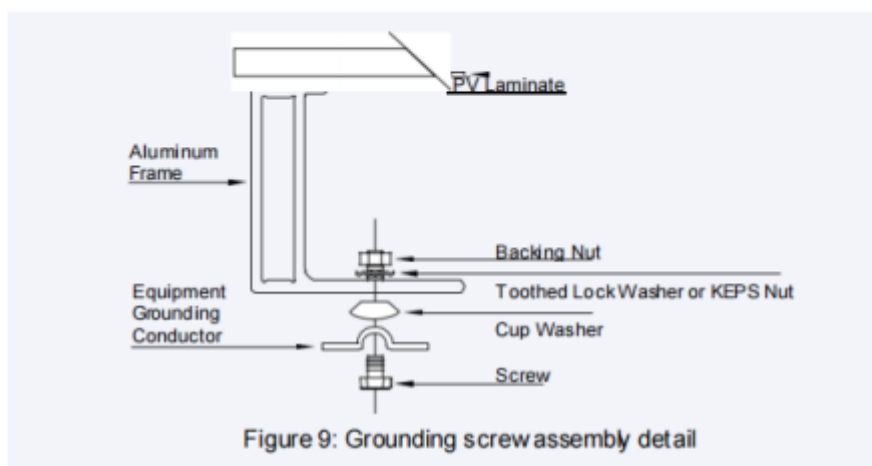

Figure 8: Grounding hole detail

The following grounding methods are available:

Option A: Screw Assembly (see Figure 9)

1. A grounding screw assembly must be attached at a designated grounding hole location using only stainless steel hardware. Insert an M3 stainless steel screw first through the stainless steel cup washer, and then through the grounding hole.
2. Loosely engage a stainless steel backing nut and toothed lock washer to the screw.
3. Bend the EGC into an omega (Ω) shape to tightly fit between the partially installed screw head and cup washer. The EGC shall be exclusively in contact with stainless steel.
4. Tighten the screw to 2.3 N-m torque. The toothed lock washer should be visibly engaged to the frame.
5. Route the appropriately sized EGC in such a way as to avoid contact with the aluminum module frame.



Option B: Racking Manufacturer Integrated Grounding Methods

HoRay Solar PV modules can be grounded by bonding PV modules to a grounded racking system. Integrated grounding methods must be certified for grounding PV modules and must be installed in accordance with the specified instructions of their respective manufacturers.

Option C: Additional Third-party Grounding Devices

HoRay Solar PV modules can be grounded using third party grounding devices so long as they are certified for grounding PV modules and the devices are installed according to the manufacturer's specified instructions.

MECHANICAL INSTALLATION

General

HoRay Solar PV Modules have been certified for a maximum static load on the back of the module of up to 1600 Pa (i.e. wind load) and a maximum static load on the front of the module of up to either 1600 Pa or 3600 Pa (i.e. wind and snow load) with a safety factor of 1.5 depending on the module type (please refer to the data sheet for this information).

Mounting structures and other mechanical parts must be designed and approved to withstand the design wind and snow loads applicable for a particular site. **HoRay Solar** PV modules must not be subjected to forces from the substructure, including forces caused by thermal expansion.

The mounting method must not result in the direct contact of dissimilar metals with the aluminum frame of the PV module that will result in galvanic corrosion. An addendum to UL Standard 1703 "Flat Plate Photovoltaic Modules and Panels" recommends metal combinations not exceed an electrochemical potential difference of 0.5 Volts.

HoRay Solar PV modules can be mounted in landscape or portrait orientation, as illustrated in Figure 10, provided that the mounting method follows one of the acceptable methods listed below.

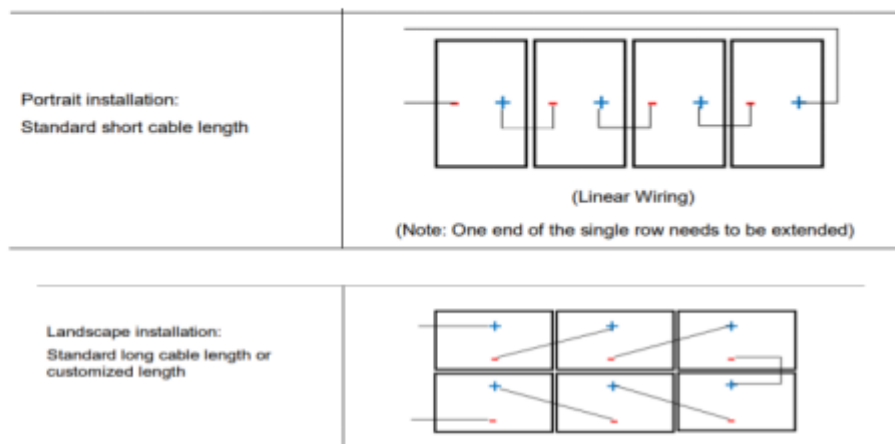

Figure 10: Landscape and portrait mounting

In order to maintain the fire class rating, the distance between the PV module front surface (glass) and the roof surface shall be at least 10 cm. This spacing also allows air flow to cool the PV module. Install PV modules with a minimum spacing of 1 cm between neighboring frames to allow for thermal expansion.

Mounting Methods

The following mounting methods are available:

Bolts or Clamps

Refer to the Module Supplement distributed with this manual to determine how many connection points are required for a specific module series. The locations of mounting holes and clamp tolerances are illustrated in the drawings located in the Module Supplement. Do not modify the existing mounting holes or drill new holes. Do not apply excessive pressure on the frame such that the frame deforms.

Bolts: Modules must be mounted using the mounting holes located on the rear side of the long frame parts using M8 stainless steel bolts, nuts, and washers. The torque of screw tightening should be between 14N · m to 20N · m.

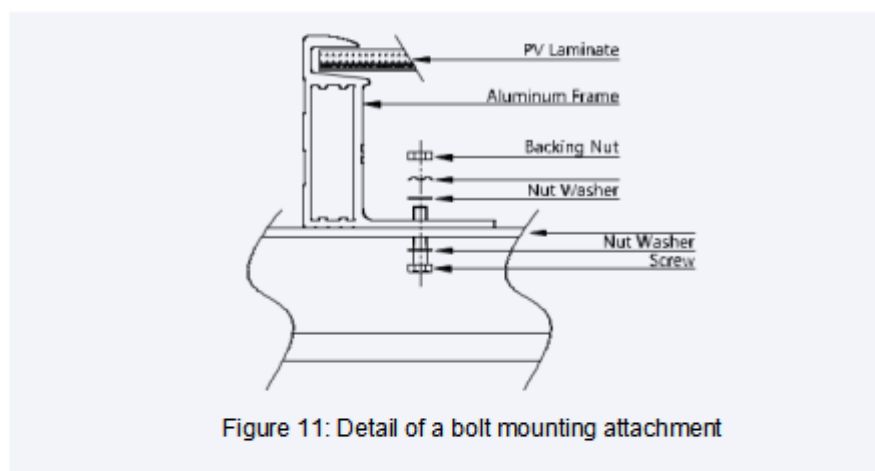

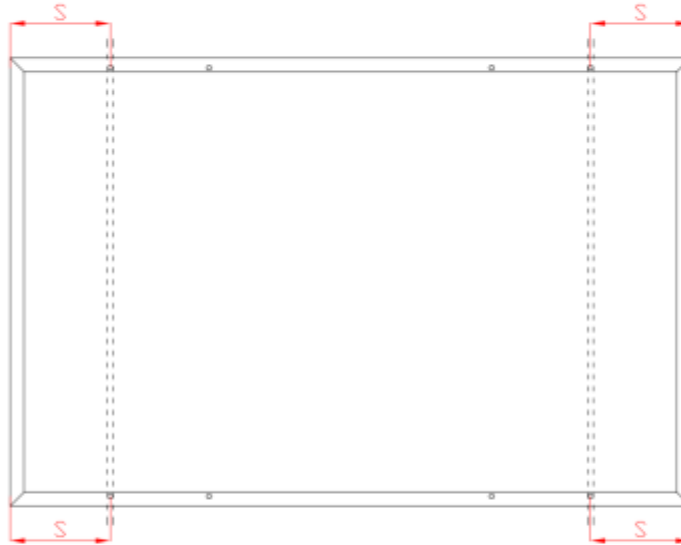

Figure12-1:Mountingrails mustrunperpendicularto thelongframe $360\text{mm} < S < 410\text{mm}$

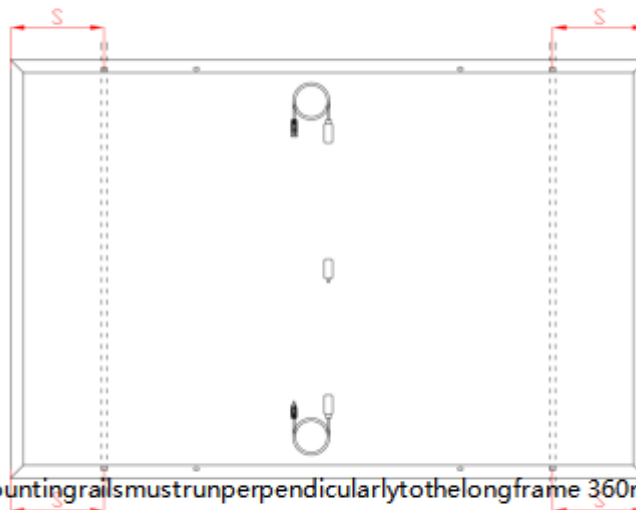
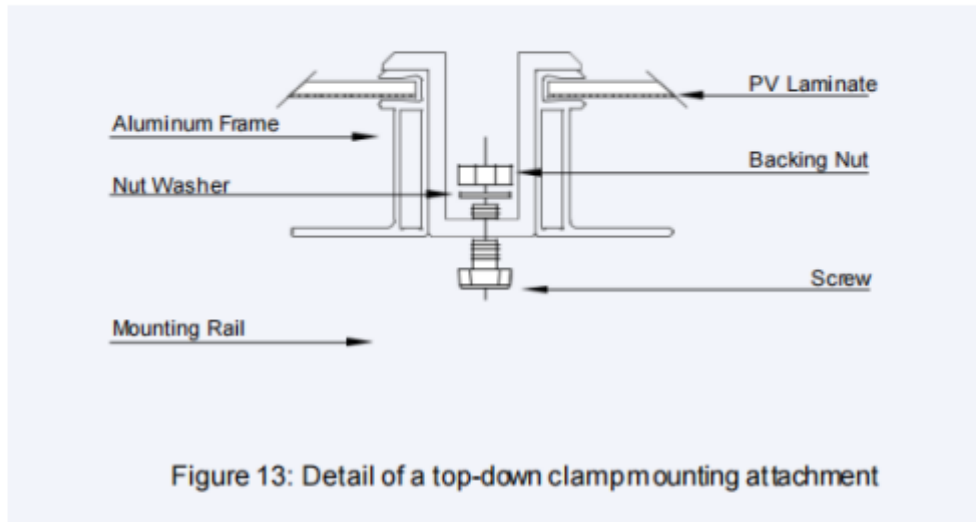

Figure12-1:Mountingrails mustrunperpendicularto thelongframe $360\text{mm} < S < 410\text{mm}$

• **Top-down Clamps:** Third-party clamps that have been designed for PV mounting structures are an approved mounting attachment method for **HoRay Solar** PV modules. Modules must be fastened using clamps applied to the top side of the long frame parts. A clamp holds two modules except for the clamps at the beginning and end of a module row. The centerline of the clamps must be in line with the mounting hole positions plus or minus a distance of 50mm. The module clamps should not contact with the front glass and deform the frame, and should avoid shadowing effects from the module clamps. The module frame is not to be modified under any circumstances. The applied torque value should be big enough to fix the modules steadily. The torque of screw tightening should be between 16N·m to 24N·m.



MAINTENANCE

General

HoRay Solar recommends that PV systems be periodically inspected by the installer, or other qualified person.

The purpose of the PV system inspection is to ensure that all system components are functioning properly. At a minimum, this inspection should confirm the following:

All cables and connector attachments are undamaged and properly secured.

- No sharp objects are in contact with the PV module surfaces.
- PV modules are not shaded by unwanted obstacles and/or foreign material.
- Mounting and grounding components are tightly secured with no corrosion. Defects should be addressed immediately.

Cleaning

Over time, dirt and dust can accumulate on the glass surface of the module, reducing its power output. **HoRay Solar** recommends periodic cleaning of PV modules to ensure maximum power output, especially in regions with low precipitation.

In order to reduce the potential for electrical and thermal shock, **HoRay Solar** recommends cleaning PV modules during early morning or late afternoon hours when solar radiation is low and the modules are cooler, especially in regions with hotter temperatures.

Never attempt to clean a PV module with broken glass or other signs of exposed wiring, as this presents a shock hazard.

Clean the glass surface of the PV modules with a soft brush using soft, clean water (PH6-9) with a recommended pressure less than 690kPa, which is typical of most municipal water systems.

Water with high mineral content may leave deposits on the glass surface and is not recommended.

HoRay Solar PV modules may contain a hydrophobic anti-reflective coating on the glass



surface to enhance power output and reduce dirt and dust buildup. In order to avoid module damage, do not clean PV modules with a power washer or pressure washer. Do not use steam or corrosive chemicals to facilitate the cleaning of modules. Do not use aggressive tools or abrasive materials that could scratch or damage the glass surface. Failure to comply with these requirements may adversely affect the PV module performance.

HoRay Solar PV modules are designed to withstand high snow loads. However, if removing snow is desired to enhance production, use a brush to gently remove snow. Do not try to remove frozen snow or ice from PV modules.

DECOMMISSIONING

The dismantling of PV systems must be performed with the same care and safety precautions used during the initial installation. The PV system can generate hazardous voltage even after the system has been disconnected. Follow safety regulations for working with live electrical equipment.

Do not dispose of electrical appliances as unsorted municipal waste, use separate collection facilities.

Contact your local government for information regarding the collection systems available.

If electrical appliances are disposed of in landfills or dumps, hazardous substances can leak into the groundwater and get into the food chain, damaging your health and well-being. When replacing old appliances with new ones, the retailer is legally obligated to take back your old appliance for disposal at least free of charge.

HoRay Solar CO.,LTD.

info@horaysolar.com

Tel:+86-510-83580688

www.horaysolar.com

HORAY SOLAR PV MODULES

Module Supplement

Revision date: 1 Jan, 2024 | Applicable for IEC certified products.

The information in this supplement is believed to be reliable, but does not constitute an expressed or implied warranty. Solar reserves the right to make changes to its PV modules and other products, their specifications, or this supplement without prior notice.

This supplement to the installation manual does not contain information about some older module series no longer being manufactured by **HoRay Solar**. If you require information about such modules, please contact **HoRay Solar**. This supplement refers to modules of the following types:

Table 1: Module types

TYPE	(Pmax) STC	(Vmpp)	(Impp)	(Voc)	(Isc)	system voltage	Fuse rating
HS640-MHG	640	37.21	17.20	45.18	18.06	1500V	30A
HS645-MHG	645	37.41	17.24	45.38	18.11	1500V	30A
HS650-MHG	650	37.61	17.28	45.58	18.16	1500V	30A
HS585-MHG	585	33.8	17.3	40.9	18.37	1500V	30A
HS590-MHG	590	34.0	17.35	41.1	18.42	1500V	30A
HS595-MHG	595	34.2	17.4	41.3	18.47	1500V	30A
HS600-MHG	600	34.4	17.44	41.5	18.52	1500V	30A
HS535-MHG	535	31.36	17.06	37.66	18.07	1500V	30A
HS540-MHG	540	31.56	17.11	37.86	18.12	1500V	30A
HS545-MHG	545	31.76	17.16	38.06	18.17	1500V	30A
HS550-MHG	550	31.96	17.21	38.26	18.22	1500V	30A
HS485-MHG	485	28.49	17.05	34.22	18.08	1500V	30A
HS490-MHG	490	28.69	17.08	34.42	18.13	1500V	30A
HS495-MHG	495	28.89	17.13	34.62	18.21	1500V	30A
HS500-MHG	500	29.09	17.19	34.82	18.29	1500V	30A
HS535-MHO	535	41.00	13.05	49.20	13.81	1500V	25A
HS540-MHO	540	41.20	13.11	49.40	13.87	1500V	25A
HS545-MHO	545	41.40	13.17	49.60	13.93	1500V	25A
HS550-MHO	550	41.60	13.23	49.80	13.99	1500V	25A
HS555-MHO	555	41.80	13.28	50.00	14.05	1500V	25A
HS560-MHO	560	42.00	13.34	50.20	14.11	1500V	25A
HS495-MHO	495	37.60	13.17	45.10	13.78	1500V	25A
HS500-MHO	500	37.80	13.23	45.30	13.83	1500V	25A
HS505-MHO	505	38.00	13.29	45.50	13.89	1500V	25A
HS510-MHO	510	38.20	13.35	45.70	13.94	1500V	25A
HS515-MHO	515	38.40	13.41	45.90	14.00	1500V	25A

HS450-MHO	450	34.60	13.01	41.40	13.68	1500V	25A
HS455-MHO	455	34.80	13.08	41.60	13.73	1500V	25A
HS460-MHO	460	35.00	13.15	41.80	13.78	1500V	25A
HS465-MHO	465	35.20	13.21	42.00	13.84	1500V	25A
HS470-MHO	470	35.40	13.28	42.20	13.90	1500V	25A
HS405-MHO	405	31.02	13.06	37.14	13.65	1500V	25A
HS410-MHO	410	31.22	13.14	37.34	13.70	1500V	25A
HS415-MHO	415	31.42	13.21	37.54	13.77	1500V	25A
HS420-MHO	420	31.62	13.28	37.74	13.86	1500V	25A
HS445-MHL	445	41.20	10.81	49.80	11.40	1500V	20A
HS450-MHL	450	41.40	10.88	50.00	11.47	1500V	20A
HS455-MHL	455	41.60	10.94	50.20	11.54	1500V	20A
HS460-MHL	460	41.80	11.00	50.40	11.61	1500V	20A
HS465-MHL	465	42.00	11.07	50.60	11.68	1500V	20A
HS410-MHL	410	37.82	10.84	45.70	11.43	1500V	20A
HS415-MHL	415	38.02	10.92	45.90	11.52	1500V	20A
HS420-MHL	420	38.22	10.99	46.10	11.61	1500V	20A
HS425-MHL	425	38.42	11.06	46.30	11.69	1500V	20A
HS370-MHL	370	34.10	10.86	41.30	11.37	1500V	20A
HS375-MHL	375	34.30	10.95	41.50	11.46	1500V	20A
HS380-MHL	380	34.50	11.04	41.70	11.55	1500V	20A
HS385-MHL	385	34.70	11.10	41.90	11.66	1500V	20A
TYPE	(Pmax)	(Vmpp)	(Imp)	(Voc)	(Isc)	system voltage	Fuse
HS80-MHG	80	21.50	3.72	25.60	3.95	1500V	15A
HS85-MHG	85	21.60	3.94	25.92	4.17	1500V	15A
HS90-MHG	90	21.70	4.15	26.04	4.40	1500V	15A
HS110-MHG	110	21.60	5.10	25.80	5.41	1500V	15A
HS115-MHG	115	21.70	5.30	25.90	5.73	1500V	15A
HS120-MHG	120	21.80	5.50	26.16	5.83	1500V	15A
HS170-MHG	170	21.70	7.84	25.90	8.31	1500V	15A
HS175-MHG	175	21.80	8.03	26.16	8.51	1500V	15A
HS180-MHG	180	21.90	8.22	26.28	8.71	1500V	15A
HS60-MHO	60	21.10	2.85	24.90	3.02	1500V	15A
HS65-MHO	65	21.20	3.07	25.44	3.25	1500V	15A
HS80-MHO	80	21.20	3.78	25.10	4.01	1500V	15A
HS85-MHO	85	21.30	3.99	25.56	4.23	1500V	15A
HS90-MHO	90	21.40	4.21	25.68	4.46	1500V	15A
HS120-MHO	120	21.30	5.64	25.20	5.98	1500V	15A
HS125-MHO	125	21.40	5.84	25.68	6.19	1500V	15A
HS130-MHO	130	21.50	6.05	25.80	6.41	1500V	15A
HS50-MHL	50	20.70	2.42	24.80	2.56	1500V	15A
HS55-MHL	55	20.80	2.64	25.00	2.80	1500V	15A

HS70-MHL	70	20.80	3.37	25.00	3.57	1500V	15A
HS75-MHL	75	20.90	3.59	25.10	3.80	1500V	15A
HS100-MHL	100	20.90	4.79	25.10	5.08	1500V	15A
HS105-MHL	105	21.00	5.00	25.20	5.30	1500V	15A
HS110-MHL	110	21.10	5.21	25.32	5.53	1500V	15A
HS590TC-MHO	590	43.44	13.59	51.63	14.38	1500V	25A
HS585TC-MHO	585	43.33	13.51	51.52	14.30	1500V	25A
HS580TC-MHO	580	43.22	13.42	51.41	14.22	1500V	25A
HS575TC-MHO	575	43.11	13.34	51.30	14.	1500V	25A
HS570TC-MHO	570	43.00	13.26	51.19	14.05	1500V	25A
HS565TC-MHO	565	42.91	13.17	51.09	13.97	1500V	25A
HS560TC-MHO	560	42.82	13.08	50.99	13.89	1500V	25A
HS540TC-MHO	540	40.64	13.29	48.27	14.35	1500V	25A
HS535TC-MHO	535	40.44	13.23	48.04	14.29	1500V	25A
HS530TC-MHO	530	40.24	13.17	47.81	14.22	1500V	25A
HS525TC-MHO	525	40.04	13.11	47.57	14.16	1500V	25A
HS520TC-MHO	520	39.84	13.05	47.33	14.10	1500V	25A
HS515TC-MHO	515	39.64	12.99	46.98	14.03	1500V	25A
HS490TC-MHO	490	36.84	13.3	43.66	14.37	1500V	25A
HS485TC-MHO	485	36.64	13.23	43.46	14.30	1500V	25A
HS480TC-MHO	480	36.44	13.17	43.26	14.22	1500V	25A
HS475TC-MHO	475	36.24	13.11	43.06	14.15	1500V	25A
HS470TC-MHO	470	36.04	13.04	42.86	14.08	1500V	25A
HS440TC-MHO	440	33.24	13.24	39.53	14.30	1500V	25A
HS435TC-MHO	435	33.04	13.17	39.33	14.22	1500V	25A
HS430TC-MHO	430	32.84	13.10	39.13	14.15	1500V	25A
HS425TC-MHO	425	32.64	13.03	38.93	14.07	1500V	25A
HS420TC-MHO	420	32.44	12.95	38.73	14.00	1500V	25A
HS445TC-MHA	445	33.19	13.41	39.77	13.87	1500V	25A
HS440TC-MHA	440	32.99	13.34	39.57	13.80	1500V	25A
HS435TC-MHA	435	32.78	13.27	39.36	13.72	1500V	25A
HS430TC-MHA	430	32.58	13.20	39.16	13.65	1500V	25A
HS425TC-MHA	425	32.37	13.13	38.95	13.58	1500V	25A
HS620TC-MHB	620	44.80	13.84	52.60	14.78	1500V	25A
HS615TC-MHB	615	44.60	13.79	52.40	14.72	1500V	25A
HS610TC-MHB	610	44.40	13.74	52.20	14.66	1500V	25A
HS605TC-MHB	605	44.20	13.69	52.00	14.60	1500V	25A
HS600TC-MHB	600	44.00	13.64	51.80	14.54	1500V	25A
HS595TC-MHB	595	43.80	13.59	51.60	14.48	1500V	25A
HS590TC-MHB	590	43.60	13.54	51.40	14.42	1500V	25A

MOUNTING REQUIREMENTS

Mounting Method: Clamps

Table 2: Mounting requirements

Modules that Require Four (4) Connection Points
HS 60Cell Series 2 HS 60Cell Series 2
HS 60Cell HS 60 Cell1 500V
HS 120 Cell half Cell HS 120 Cell half Cell
HS 60Cell HS 60Cell

ELECTRICAL CHARACTERISTICS

Nameplate ratings are average values. The electrical characteristics are within +/- 10 percent of the indicated values of I_{sc} , V_{oc} , and P_{max} under Standard Test Conditions (irradiance of 1000 W/m², AM 1.5 spectrum, and a cell temperature of 25°C). Refer to module datasheets for specific power output tolerances. Please refer to Table 1 to see which power classes actually exist for which module series.

REAR AND SIDE VIEW DIMENSIONS OF MODULE SERIES WITH 30MM FRAME (CONT.)

UNITS: mm

HORAY 108 Cells

(also valid for HORAY108 Cells)

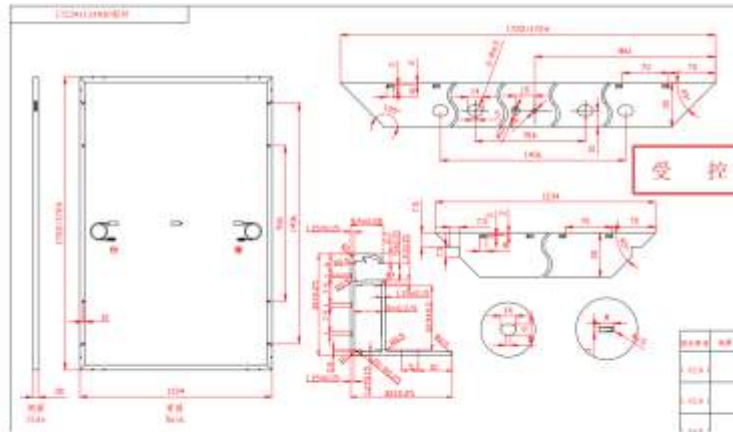

HORAY 120 Cells

(also valid for HORAY120 Cells)

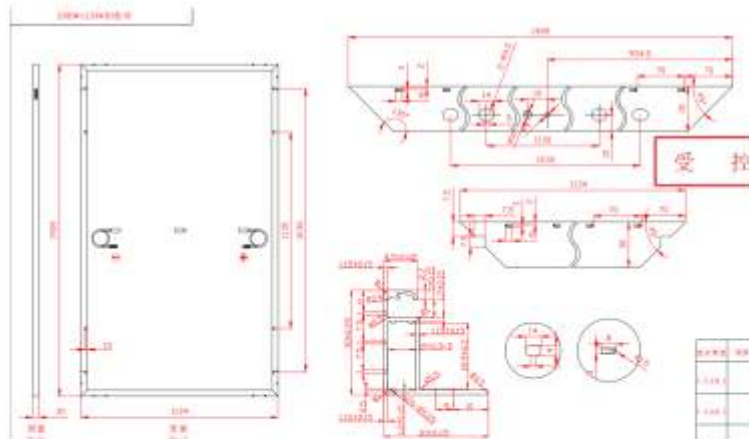

HORAY 132 Cell half Cell

(also valid for HORAY 132 Cell Half cell)

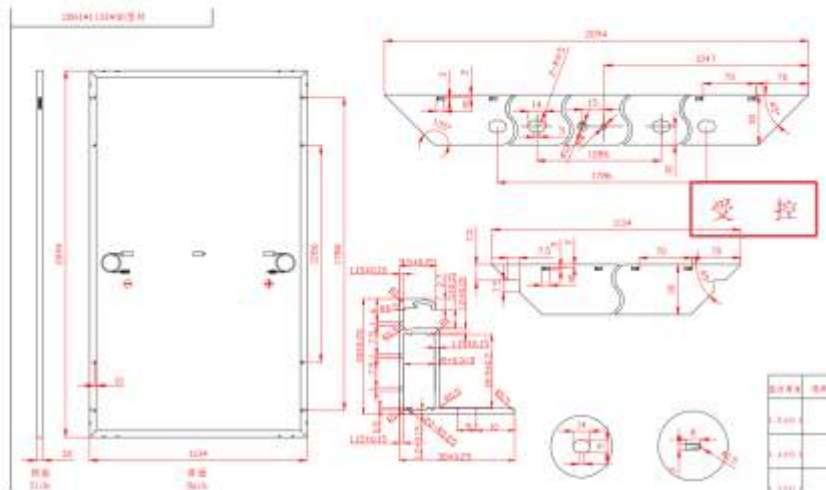

HORAY 144 Cell half Cell
(also valid for HORAY144 Cell Half cell)

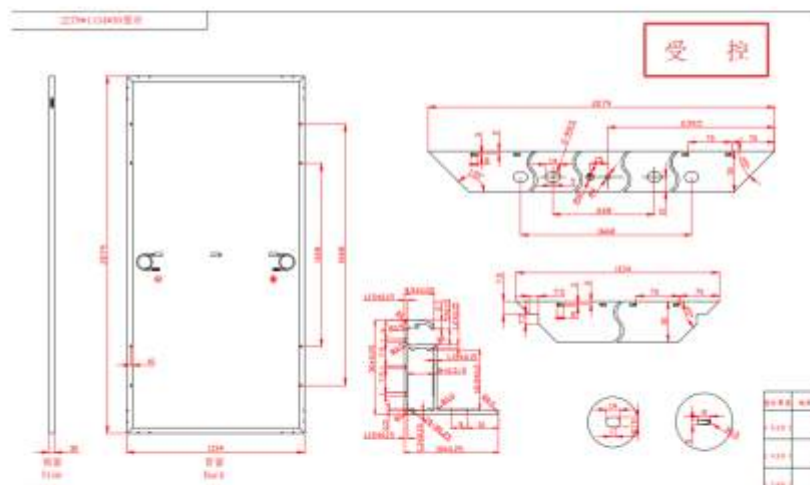

HoRay Solar Co.,LTD.

No. 30-5, Yanxin East Road, Huishan District, Wuxi City, Jiangsu, P.R. China

info@Horaysolar.com

Tel:+86-510-83580688

www.horaysolar.com

HORAY

EXCELLENT PV MODULE MANUFACTURER

HORAY SOLAR CO., LTD.

 No.30-5 East Yanxin Road, Huishan District, Wuxi, Jiangsu, China

 +86 510 83580688

 www.horaysolar.com

 sales@horaysolar.com



Scan the QR code
to follow WeChat



Scan the QR code
to follow LinkedIn



ACHYRA[®]

Soluzioni Energetiche Sostenibili

Milano - Nola - HongKong - Guangzhou

ZAVORRE



Tipo	AZ-01
Luogo di installazione	Tetto piano in cemento / Terra
Angolo di installazione	5°
Resistenza al vento	40 m/s (Max. Categoria 13 Typhoon)
Dimensione del modulo	Universale
Tipo di carico	Riempibile ad acqua
Materiali	HDPE Polietilene ad alta densità + Anti-UV e anti-usura
Dimensioni	1470 x 415 x 300 (mm)
Tempo di installazione	<1 Minuto / Modulo
Temperatura di esercizio	-40°C to 85°C
Installazione Modulo	Verticale
Peso	< 6 kg / Unità
Tipo di Modulo	Universale
Carico massimo d'acqua	120 kg / Unità
Materiale fissaggi	ALLUMINIO AL6063-T5
Volume	36 Unità / 5,85 m³
Quantità contenitore	452 pz / 40 HQ
Riciclabilità dei materiali	Completamente riciclabile
Garanzia	Durabilità 25 anni Garanzia di 10 anni

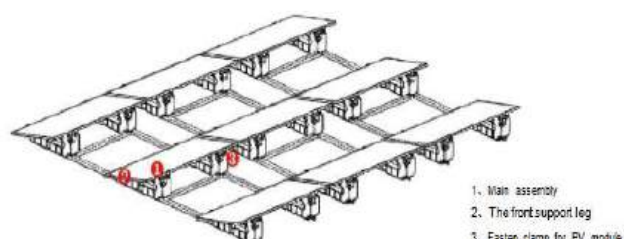
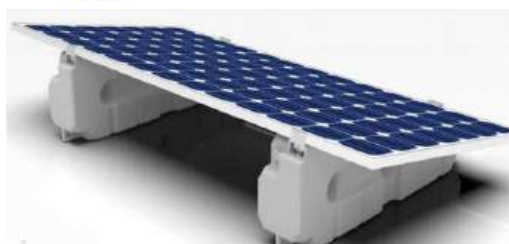

Tipo	AZ-02
Luogo di installazione	Tetto piano in cemento / Terra
Angolo di installazione	12°
Resistenza al vento	40m/s(Categoria massima di tifone 13)
Dimensioni del modulo FV	(L: 1134 mm * P: illimitato)
Tipo di carico	Riempibile ad acqua
Materiali	HDPE Polietilene ad alta densità
	Anti-UV e anti-usura
Dimensioni	1150 x 383 x 220 (mm)
Tempo di installazione	<1 minuto / modulo
Temperatura di esercizio	-40°C to 85°C
Quantità contenitore	450 unità / 40 HQ
Installazione Modulo	Orizzontale
Peso	<10 kg / Unità
Carico massimo di acqua	60 kg / Unità
Materiale fissaggi	ALLUMINIO AL6063-T5
Volume	18 Unità / 1,2 m³
Riciclabilità dei materiali	Completamente riciclabile
Garanzia	Durabilità 25 anni
	Garanzia di 10 anni